



MAE series motor adapt the advanced high speed Gerolor gear set designed with disc distribution flow and high pressure, and have good stability in low speed, and can keep high volume efficiency. The unit can be supplied the individual variant operating multifunction in accordance with requirement of applications.

Specifications

TYPE		MAE(W) 65	MAE(W) 80	MAE(W) 100	MAE(W) 125	MAE(W) 160	MAE(W) 200	MAE(W) 230	MAE(W) 250	MAE(W) 295	MAE(W) 315	MAE(W) 375
Displacement (c.c/rev)		66.8	81.3	101.6	127	157.2	193.6	226	257	287.8	314.5	370
Max. speed (rpm)	Cont	667	543	439	350	283	229	247	216	196	178	152
	Int(3)	842	689	553	441	355	289	328	287	254	235	199
Max. Torque (da Nm)	Cont	12.6	15.7	19.1	24.5	30.7	38.2	37.8	38.1	39.3	44.8	43.9
	Int(3)	17.6	21.5	26.8	33.5	42.2	52	52.8	54.3	54.7	58.7	61.3
	Peak(4)	17.8	21.6	27	33.8	42.5	52.1	54.1	61.5	65.1	66.9	78.9
Max. output (Kw)	Cont	8.3	8.8	7.9	8.9	8.9	9	9.9	9.3	8.7	8	7.6
	Int(3)	13.9	14.4	13.5	14.1	15.6	15.7	17.9	16.5	15.6	14.3	14
Max. pressure drop (bar)	Cont	140	140	140	140	140	140	120	110	100	100	90
	Int(3)	190	190	190	190	190	190	165	155	145	135	125
	Peak(4)	200	200	200	200	200	200	180	180	170	160	160
Max. oil flow (l/min)	Cont	45	45	45	45	45	45	57	57	57	57	57
	Int(3)	57	57	57	57	57	57	75	75	75	75	75
Max. Inlet pressure (bar)	Cont	175	175	175	175	175	175	175	175	175	175	175
	Int(3)	200	200	200	200	200	200	200	200	200	200	200
	Peak(4)	225	225	225	225	225	225	225	225	225	225	225
Weight (kg)		7.4	7.5	7.8	8	8.3	8.7	9.2	9.6	10	10.3	10.8

(3) Intermittent operation rating applies to 6 sec. of every minute

(4) Peak load rating applies to 0.6 sec of every minute

TYPE		MAE(W) 65	MAE(W) 80	MAE(W) 100	MAE(W) 125	MAE(W) 160	MAE(W) 200	MAE(W) 230	MAE(W) 250	MAE(W) 295	MAE(W) 315	MAE(W) 375
Displacement (in.3/r)		4.1	5.0	6.2	7.7	9.6	11.8	13.8	15.7	17.6	19.2	22.6
Max. speed (rpm)	Cont	667	543	439	350	283	229	247	216	196	178	152
	Int(3)	842	689	553	441	355	289	328	287	254	235	199
Max. Torque (lb-in)	Cont	1115	1389	1690	2168	2717	3381	3345	3372	3478	3965	3885
	Int(3)	1558	1903	2372	2965	3735	4602	4673	4806	4841	5195	5425
	Peak(4)	1572	1913	2391	2989	3761	4611	4787	5443	5757	5291	6966
Max. output (hp)	Cont	11.1	11.8	10.6	11.9	11.9	12.1	13.3	12.5	11.7	10.7	10.2
	Int(3)	18.6	19.3	18.1	18.9	20.9	21.0	24.0	22.1	20.9	19.2	18.8
Max. pressure drop (psi)	Cont	2000	2000	2000	2000	2000	2000	1710	1580	1430	1430	1290
	Int(3)	2720	2720	2720	2720	2720	2720	2360	2220	2080	1930	1780
	Peak(4)	2860	2860	2860	2860	2860	2860	2570	2570	2430	2290	2290
Max. oil flow (gpm)	Cont	11.9	11.9	11.9	11.9	11.9	11.9	15.1	15.1	15.1	15.1	15.1
	Int(3)	15.1	15.1	15.1	15.1	15.1	15.1	19.8	19.8	19.8	19.8	19.8
Max. Inlet pressure (psi)	Cont	2540	2540	2540	2540	2540	2540	2540	2540	2540	2540	2540
	Int(3)	2900	2900	2900	2900	2900	2900	2900	2900	2900	2900	2900
	Peak(4)	3260	3260	3260	3260	3260	3260	3260	3260	3260	3260	3260
Weight (lbs)		16.4	16.7	17.3	17.8	18.4	19.3	20.4	21.3	22.2	22.9	24.0

Performance Data

MAE65

Pressure (Mpa) Max. cont. Max. Int.

3.5	7	10.5	14	19
-----	---	------	----	----

Flow (L/min)	2	26 22	54 16	83 4		
	5	27 69	56 62	87 53	118 42	
	10	29 145	60 141	91 132	123 122	171 95
	15	30 221	62 216	94 207	126 196	176 149
	20	28 295	58 290	91 279	122 261	174 232
	25	24 368	55 365	90 352	121 341	172 312
	34	22 501	54 493	89 478	119 457	171 423
	Max. cont.	20 667	52 660	85 642	115 621	166 587
	Max. Int.	15 842	46 835	80 814	112 789	163 735
	57					

MAE80

Pressure (Mpa) Max. cont. Max. Int.

3.5	7	10.5	14	19
-----	---	------	----	----

Flow (L/min)	2	33 18	70 14	106 4		
	5	35 55	72 51	111 44	150 25	
	10	36 121	75 118	114 113	155 107	215 88
	15	37 181	77 178	116 171	157 162	215 148
	20	35 242	74 238	112 231	151 223	206 205
	25	35 303	71 298	108 289	148 275	202 261
	34	31 441	69 407	105 396	145 382	198 373
	Max. cont.	23 543	62 537	100 521	139 513	12 501
	Max. Int.	18 689	55 681	98 665	134 649	186 618
	57					

MAE100

Pressure (Mpa) Max. cont. Max. Int.

3.5	7	10.5	14	19
-----	---	------	----	----

Flow (L/min)	2	40 15	82 11	126 4		
	5	41 44	83 36	150 28	206 12	
	10	42 97	91 95	138 94	177 81	230 54
	15	42 147	91 144	138 137	185 124	257 93
	20	38 195	88 192	136 182	180 169	244 138
	25	39 244	89 241	142 230	191 221	268 194
	34	31 331	79 328	131 323	179 308	250 273
	Max. cont.	21 439	70 436	119 433	168 419	241 383
	Max. Int.	10 553	60 545	109 534	158 527	232 491
	57					

MAE125

Pressure (Mpa) Max. cont. Max. Int.

3.5	7	10.5	14	19
-----	---	------	----	----

Flow (L/min)	2	52 12	150 9	158 3		
	5	55 35	112 31	170 22	221 15	290 10
	10	57 78	117 75	180 69	242 63	335 46
	15	56 116	118 113	180 109	245 99	331 76
	20	55 155	117 153	178 147	242 136	331 110
	25	52 593	111 188	177 182	238 172	325 151
	34	43 264	105 262	169 254	234 244	326 220
	Max. cont.	38 350	95 348	159 346	219 331	314 301
	Max. Int.	21 441	176 439	141 431	280 417	302 384
	57					

MAE160

Pressure (Mpa) Max. cont. Max. Int.

3.5	7	10.5	14	19
-----	---	------	----	----

Flow (L/min)	2	64 10	132 8	199 2		
	5	68 28	138 26	208 19	281 10	
	10	71 62	147 60	221 56	303 53	419 38
	15	72 93	148 91	225 87	307 79	426 61
	20	71 126	148 123	223 118	305 110	422 95
	25	62 157	140 155	218 152	296 141	415 129
	34	56 124	134 211	211 206	287 197	408 181
	Max. cont.	47 283	127 281	205 275	281 266	391 241
	Max. Int.	36 355	97 352	182 346	260 336	370 311
	57					

MAE200

Pressure (Mpa) Max. cont. Max. Int.

3.5	7	10.5	14	19
-----	---	------	----	----

Flow (L/min)	2	80 9	163 7	245 3		
	5	88 23	178 21	266 18	352 12	
	10	89 49	181 48	275 43	378 39	517 27
	15	91 76	188 73	280 68	382 63	520 44
	20	89 101	182 98	275 95	374 86	517 69
	25	78 127	170 125	271 121	376 113	518 101
	34	64 173	158 171	268 165	363 156	502 143
	Max. cont.	51 229	157 227	252 221	351 212	494 196
	Max. Int.	36 289	138 286	231 279	330 271	469 256
	57					

Continue
 Intermittent

Performance Data

MAE230

Pressure (Mpa)

Max. cont. Max. Int.

3.5	7	10.5	12	16.5
-----	---	------	----	------

	2	97 7	191 4	280 2		
	5	101 18	199 14	301 8	348 4	
	10	103 43	214 42	325 40	378 36	527 29
	15	104 65	215 63	327 59	375 52	528 47
	20	101 86	210 84	321 81	371 75	524 66
	25	95 108	201 106	316 102	364 94	511 87
	34	82 147	188 145	308 141	358 135	501 128
	45	55 197	158 195	276 191	329 186	485 176
Max. cont.	57	19 247	130 244	256 240	301 230	451 221
Max. Int.	75		65 328	183 323	250 311	401 303

MAE250

Pressure (Mpa)

Max. cont. Max. Int.

3.5	7	10.5	11	15.5
-----	---	------	----	------

	2	112 6	207 3	309 1		
	5	115 18	218 14	320 8	348 4	
	10	113 39	235 38	358 35	379 31	543 23
	15	113 58	234 56	357 53	381 45	542 3
	20	111 77	233 75	356 72	376 65	541 48
	25	109 97	228 95	354 89	371 81	532 69
	34	91 131	213 128	346 123	364 116	521 103
	45	89 174	211 172	345 165	361 157	518 135
Max. cont.	57	73 216	208 213	339 205	342 197	487 184
Max. Int.	75		74 287	198 284	301 278	441 267

MAE295

Pressure (Mpa)

Max. cont. Max. Int.

3.5	7	11	14.5
-----	---	----	------

	5	121 15	243 14	368 10	509 5
	10	125 33	253 31	381 27	529 20
	15	129 51	261 50	393 47	547 41
	20	127 68	259 67	390 63	545 55
	25	126 86	255 84	366 80	539 69
	34	123 116	248 114	380 110	531 98
	45	115 154	234 153	368 148	522 136
Max. cont.	57	108 196	227 194	359 187	514 176
Max. Int.	75		211 254	349 246	506 231

MAE315

Pressure (Mpa)

Max. cont. Max. Int.

3.5	7	11	13.5
-----	---	----	------

	5	136 11	281 8	427 3	
	10	139 30	287 29	438 26	574 20
	15	141 47	295 46	448 43	587 40
	20	138 62	287 61	442 58	587 53
	25	131 78	280 75	431 71	567 66
	34	117 106	269 104	423 98	557 91
	45	114 141	253 138	397 132	535 125
Max. cont.	57	86 178	219 173	383 168	505 162
Max. Int.	75		108 235	287 231	416 219

MAE375

Pressure (Mpa)

Max. cont. Max. Int.

3.5	7	9	12.5
-----	---	---	------

	5	151 50	315 7	412 3	
	10	155 25	324 24	427 21	606 18
	15	162 40	331 39	439 37	613 32
	20	158 53	326 52	434 49	602 45
	25	151 67	316 65	424 62	589 58
	34	141 91	309 89	417 85	580 80
	45	138 121	300 119	408 115	572 107
Max. cont.	57	118 152	281 150	393 144	550 136
Max. Int.	75		258 199	369 191	518 183

□ Continue
■ Intermittent

Dimensions and Mounting Data

Type	L inch [mm]	L ₁ inch [mm]
MAE(W)65	4.69[119]	0.51[13]
MAE(W)80	4.80[122]	0.63[16]
MAE(W)100	4.96[126]	0.79[20]
MAE(W)125	5.16[131]	0.98[25]
MAE(W)160	5.37[136.5]	1.20[30.5]
MAE(W)200	5.67[144]	1.50[38.1]
MAE(W)230	5.91[150]	1.73[44]
MAE(W)250	6.14[156]	1.97[50]
MAE(W)295	6.38[162]	2.20[56]
MAE(W)315	6.61[168]	2.44[62]
MAE(W)375	7.09[180]	2.91[74]

[mm] show in brackets []

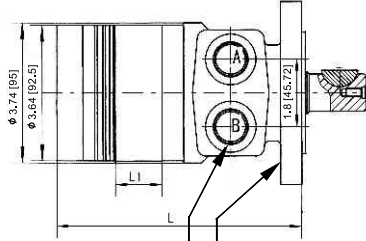

Porting

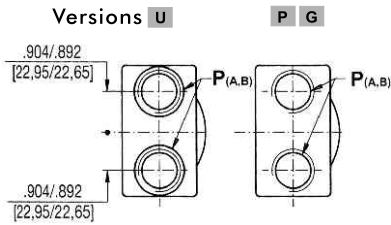

Versions MU Manifold

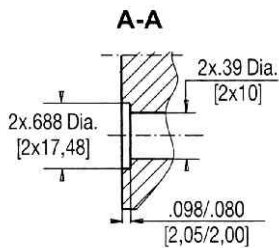
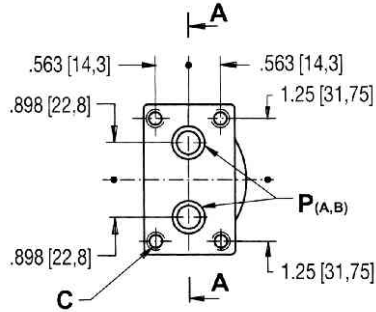

Code	Versions			
	Omit	P	G	MU
P(A,B)	7/8-14UNF	1/2-14NPTF	G 1/2	.39 Dia.[ϕ 10]
T	7/16-20UNF	7/16-20UNF	G 1/4	7/16-20UNF
C	-	-	-	5/16-18UNC

Mounting

SAE.A Mounting

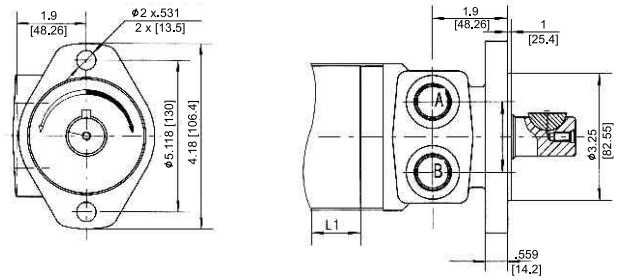

Q Square Mounting

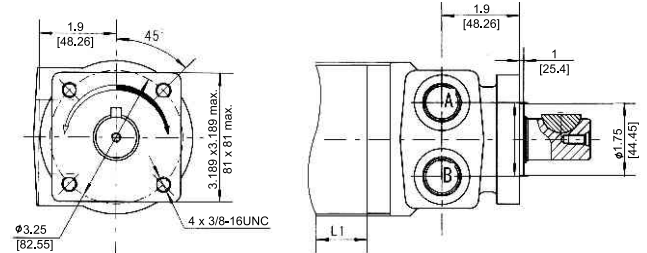

W Wheel Mounting

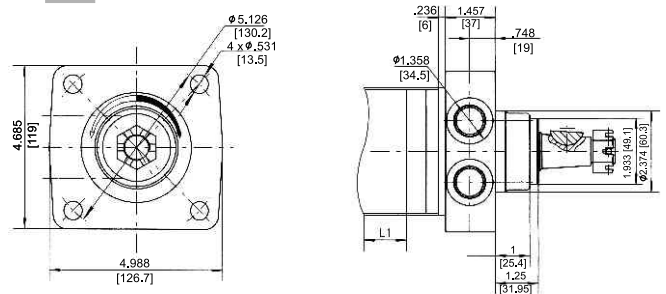

Shaft Extensions for MAE Motor

(mm) show in brackets []

C $\varnothing 25$, Parallel key A8x7x32
Max. Torque 3900 in-lb [44 daNm]

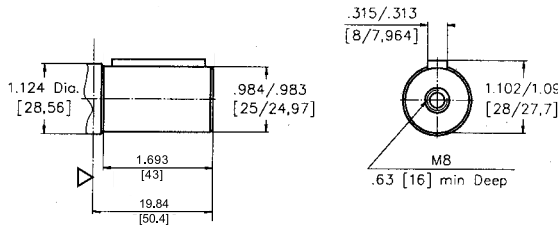

HA 1" [25,4] Straight, w/ .315[8] Crosshole
Max. Torque 3900 in-lb [44 daNm]

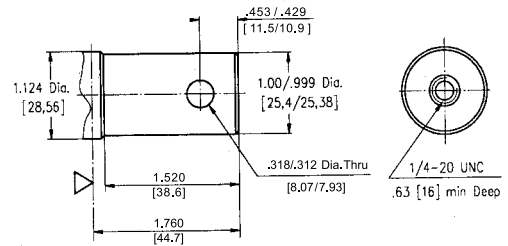

CO 1" [25,4], Woodruff key 1/4"x1"
Max. Torque 3900 in-lb [44 daNm]

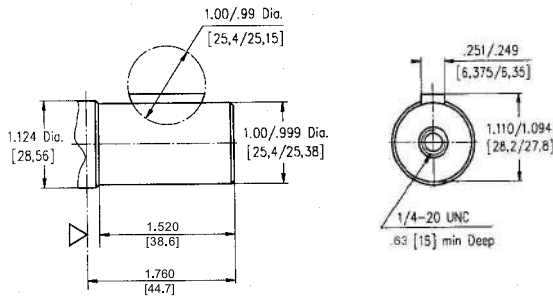

S 1" [25,4], SAE 6B Splined
Max. Torque 3900 in-lb [44 daNm]

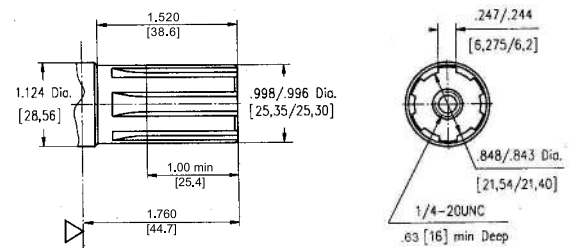

T 1" [25,4] SAE J501 Tapered
Woodruff key 1/4" x 1" SAE J502
Max. Torque 3900 in-lb [44 daNm]

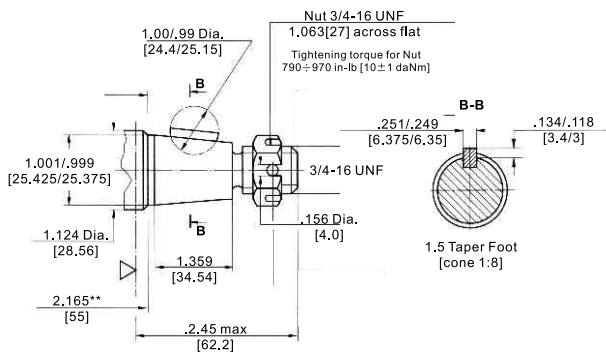

H 1" [25,4] Straight w/ .406[10,3] Crosshole
Max. Torque 3900 in-lb [44 daNm]

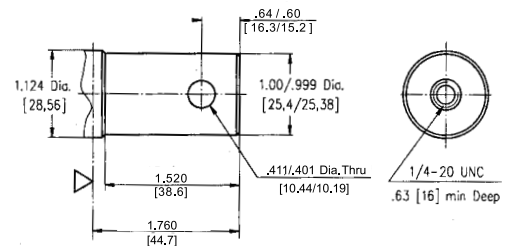

	1	2	3	4	5	6
MAE						

Pos.1 Mounting

Omit - Oval Mount SAE. A

Q - Square Mount 4 Bolts

W - Wheel Mount

Pos.2 Displacement Code

65 - 66.8cc / 4.1 [in.3/r]

80 - 81.3cc / 5.0 [in.3/r]

100 - 101.6cc / 6.2 [in.3/r]

125 - 127.0cc / 7.7 [in.3/r]

160 - 157.2cc / 9.6 [in.3/r]

200 - 193.6cc / 11.8 [in.3/r]

230 - 226.0cc / 13.8 [in.3/r]

250 - 257.0cc / 15.7 [in.3/r]

295 - 287.8cc / 17.6 [in.3/r]

315 - 314.5cc / 19.2 [in.3/r]

375 - 370.0cc / 22.6 [in.3/r]

Pos.3 Shaft Extensions

C - ϕ 25 Parallel key A8 x 7 x 32

CO - 1" [25.4], Woodruff key 1/4" x 1"

S - 1" [25.4], SAE. 6B Splined

T - 1" [25.4], SAE. J501 Tapered Woodruff key 1/4" x 1" SAE. J502

H - 1" [25.4], Straight w/.406 [10.3] Crosshole

HA - 1" [25.4], Straight w/.315 [8.0] Crosshole

Pos.4 Porting

Omit - 2 x 7/8 - 14 UNF

P - 2 x 1/2 - 14 NPTF

G - 2 x G 1/2

MU - Manifold

Pos.5 Painting

Omit - Grey

B - Black

00 - No Paint

Pos.6 Rotation

Omit - Standard Rotation

R - Reverse Rotation