

NOT AVAILABLE

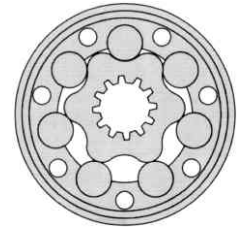

Application

- Application
- Conveyors
- Feeding mechanism of robots and manipulators
- Metal working machines
- Textile machines
- Food Industries
- Grass cutting machinery etc.

Specifications

TYPE		MAHW 125	MAHW 160	MAHW 200	MAHW 235	MAHW 250	MAHW 300	MAHW 315	MAHW 350	MAHW 370	MAHW 400	MAHW 470	MAHW 500	MAHW 535	MAHW 550
Displacement (c.c/rev)		127.9	158.1	203.2	233.3	255.9	293.5	316.1	346.2	368.8	406.4	474.2	489.2	534.4	557
Max. speed (rpm)	Cont	383	374	289	254	229	201	187	171	161	145	124	120	110	106
	Int(3)	475	469	364	316	288	251	234	213	199	181	153	149	137	131
Max. Torque (da Nm)	Cont	34.2	44.9	54.3	62.6	67.4	78.1	85.3	90.9	98.5	100	97	111	93.9	94
	Int(3)	38	49.6	60.1	68.7	75.3	88.7	95.2	99.9	109.7	101.8	106.9	113	108.5	108.7
	Peak(4)	41.8	51.6	66.3	76.2	83.5	95.8	103.2	113	120.4	116.7	123.8	127.8	125.6	130.9
Max. output (Kw)	Cont	12	14.4	14.1	13.5	13.5	13.2	13.4	12.8	12.9	12.1	10.2	10.2	9.3	9
	Int(3)	15.7	18.1	19.1	18.5	18.8	18	17.7	17.5	17.3	14.9	13.3	13.3	12.2	11.9
Max. pressure drop (bar)	Cont	205	205	205	205	205	205	205	205	205	185	165	150	130	125
	Int(3)	225	225	225	225	225	225	225	225	225	190	175	165	150	145
	Peak(4)	250	250	250	250	250	250	250	250	250	220	200	200	180	180
Max.oil flow (l/min)	Cont	60	75	75	75	75	75	75	75	75	75	75	75	75	75
	Int(3)	80	90	90	90	90	90	90	90	90	90	90	90	90	90
Max. Inlet pressure (bar)	Cont	220	220	220	220	220	220	220	220	220	220	220	220	220	220
	Int(3)	225	225	225	225	225	225	225	225	225	225	225	225	225	225
	Peak(4)	250	250	250	250	250	250	250	250	250	250	250	250	250	250
Weight (kg)		10.3	10.6	11.7	11.9	12.3	12.5	12.7	12.8	13	14.3	14.6	15	15.1	15.5

(3) Intermittent operation rating applies to 6 sec. of every minute

(4) Peak load rating applies to 0.6 sec of every minute

TYPE		MAHW 125	MAHW 160	MAHW 200	MAHW 235	MAHW 250	MAH 300	MAH 315	MAHW 350	MAHW 370	MAHW 400	MAHW 470	MAHW 500	MAHW 535	MAHW 550
Displacement (in.3/r)		7.8	9.6	12.4	14.2	15.6	17.9	19.3	21.1	22.5	24.8	28.9	29.8	32.6	34.0
Max. speed (rpm)	Cont	383	374	289	254	229	201	187	171	161	145	124	120	110	106
	Int(3)	475	469	364	316	288	251	234	213	199	181	153	149	137	131
Max. Torque (lb-in)	Cont	3027	3974	4806	5540	5965	6912	7549	8045	8717	8850	8585	9824	8310	8319
	Int(3)	3363	4390	5319	6080	6664	7850	8425	8841	9708	9009	9461	10001	9602	9620
	Peak(4)	3695	4567	5870	6740	7393	847	9132	10001	10654	10332	10959	11306	11116	11586
Max. output (hp)	Cont	16.1	19.3	18.9	18.1	18.1	17.7	18.0	17.2	17.3	16.2	13.7	13.7	12.5	12.1
	Int(3)	21.0	24.3	25.6	24.8	25.2	24.1	23.7	23.5	23.2	20.0	17.8	17.8	16.4	16.0
Max. pressure drop (psi)	Cont	2973	2973	2973	2973	2973	2973	2973	2973	2973	2683	2393	2175	1885	1813
	Int(3)	3263	3263	3263	3263	3263	3263	3263	3263	3263	2755	2538	2393	2175	2103
	Peak(4)	3625	3625	3625	3625	3625	3625	3625	3625	3625	3190	2900	2900	2610	2610
Max.oil flow (gpm)	Cont	16	20	20	20	20	20	20	20	20	20	20	20	20	20
	Int(3)	21	24	24	24	24	24	24	24	24	24	24	24	24	24
Max. Inlet pressure (psi)	Cont	2860	2860	2860	2860	2860	2860	2860	2860	2860	2860	2860	2860	2860	2860
	Int(3)	3218	3218	3218	3218	3218	3218	3218	3218	3218	3218	3218	3218	3218	3218
	Peak(4)	3575	3575	3575	3575	3575	3575	3575	3575	3575	3575	3575	3575	3575	3575
Weight (lbs)		23	24	26	26	27	28	28	28	29	32	32	33	34	34

Dimensions and Mounting Data

[inch] show in brackets []

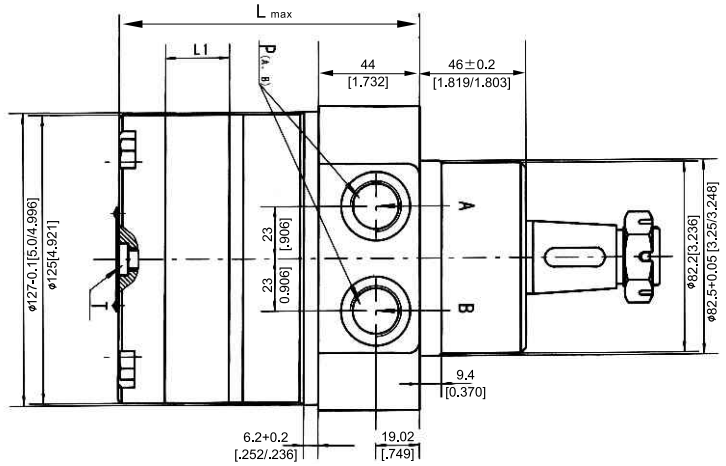
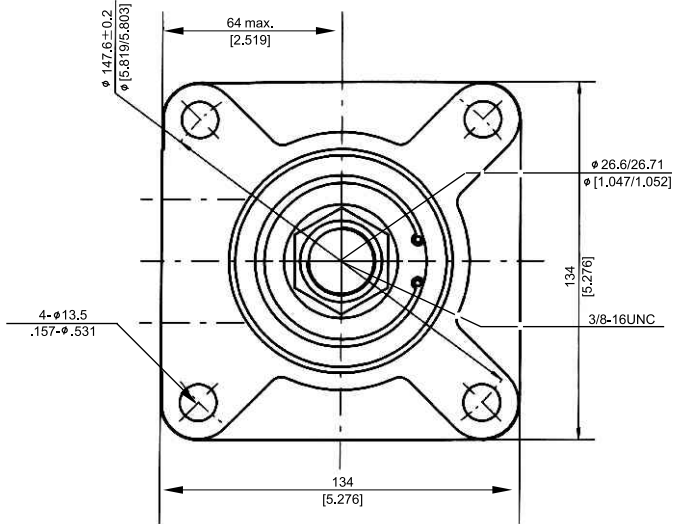

Type	L	L ₁
MAHW 125	121[4.763]	17[.609]
MAHW 160	125[4.921]	21[.827]
MAHW 200	131[5.157]	27[1.063]
MAHW 235	135[5.315]	31[1.220]
MAHW 250	138[5.433]	34[1.339]
MAHW 300	143[5.630]	39[1.535]
MAHW 315	146[5.748]	42[1.654]
MAHW 350	150[5.906]	46[1.811]
MAHW 370	153[6.024]	49[1.929]
MAHW 400	158[6.220]	54[2.126]
MAHW 500	169[6.654]	65[2.559]
MAHW 535	175[6.890]	71[2.795]
MAHW 550	178[7.008]	74[2.913]

Code	Versions			
	Omit	M	U	P
P(A,B)	2 x G 1/2	2 x M22 x 1.5	2 x 7/8-14UNF	2 x 1/2-14NPTF
T	G 1/4	M14 x 1.5	7/16-20UNF	7/16-20UNF

Permissible Shaft Loads

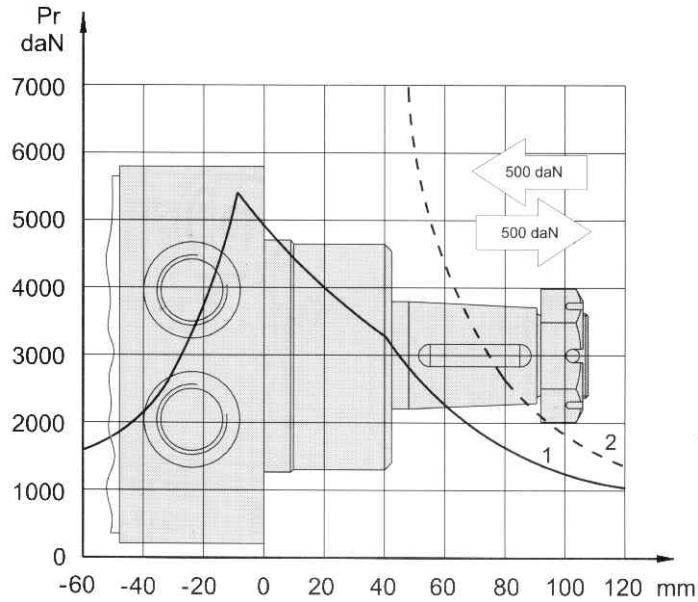

- 1 - Bearing Curve: The curve applies to a B10 bearing life of 2000 hours at 100RPM.
- 2- Shaft Curve: The curve represents Max. Permissible radial shaft load with safety factor 3:1

Max. Permissible Shaft Seal Pressure

MAHW... Motors with drain connection:

The shaft seal pressure equals the pressure in the drain line.

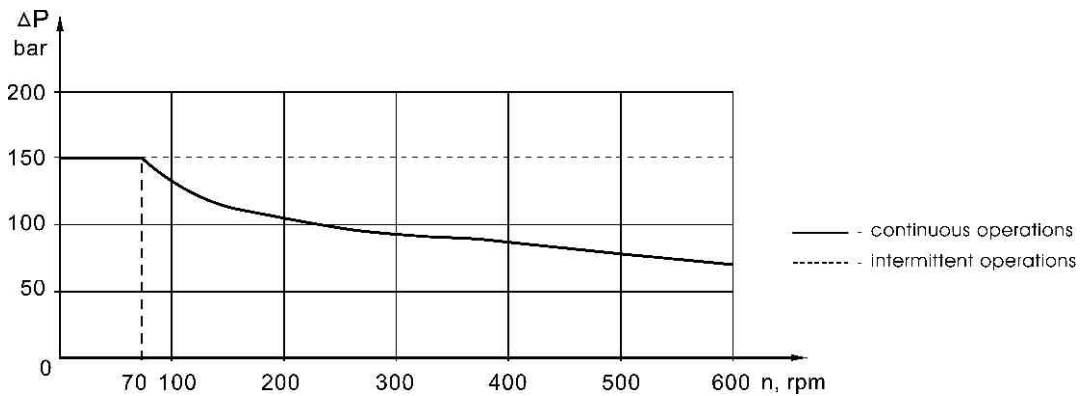
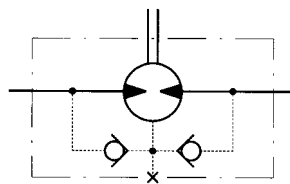

MAHW	1	2	3	4	5	6
-------------	---	---	---	---	---	---

Pos.1 Displacement Code

- 125** - 127.9cc / 7.8 [in.3/r]
- 160** - 158.1cc / 9.6 [in.3/r]
- 200** - 203.2cc / 12.4 [in.3/r]
- 235** - 233.3cc / 14.2 [in.3/r]
- 250** - 255.9cc / 15.6 [in.3/r]
- 300** - 293.5cc / 17.9 [in.3/r]
- 315** - 316.1cc / 19.3 [in.3/r]
- 350** - 346.2cc / 21.1 [in.3/r]
- 370** - 368.8cc / 22.5 [in.3/r]
- 400** - 406.4cc / 24.8 [in.3/r]
- 470** - 474.2cc / 28.9 [in.3/r]
- 500** - 489.2cc / 29.8 [in.3/r]
- 535** - 534.4cc / 32.6 [in.3/r]
- 550** - 557.0cc / 34.0 [in.3/r]

Pos.2 Shaft Extensions (See Page 40)

- C** - ϕ 32 Straight, Parallel key A10 x 8 x 45
- CO** - ϕ 31.75 [1 1/4"] Straight, Parallel key 5/16" x 5/16" x 1 1/4"
- CB** - ϕ 35 Straight, Parallel key A10 x 8 x 45
- SH** - ϕ 31.75 [1 1/4"] Splined 14T, DP12/24
- SB** - ϕ 31.75 [1 1/4"] Splined 14T, DP12/24
- TB** - Tapered 1:10, Parallel key B6 x 6 x 20
- TA** - Tapered 1:8 SAE. J501, Parallel key 5/16" x 5/16" x 1 1/4"
- S** - ϕ 25,32 Splined (SAE 6B)

Pos.3 Drain Port

- Omit - With Drain Port
- 1** - Without Drain Port

Pos.4 Porting

- Omit - 2 x G 1/2
- M** - 2 x M22 x 1.5
- U** - 2 x 7/8 - 14UNF
- P** - 2 x 1/2 - 14NPTF

Pos.5 Painting

- Omit - Grey
- B** - Black
- 00** - No Paint

Pos.6 Rotation

- Omit - Standard Rotation
- R** - Reverse Rotation