

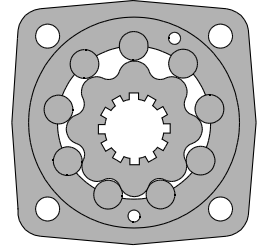

The MAT motor is six larger displacements, industry standard mounting flanges and output shafts which allows the motor to be easily applied in a wide range of applications requiring larger output shaft torque. This type motors is constant working displacement and achieve high torque at low speed.



Specifications

TYPE		MAT(E) 160	MAT(E) 200	MAT(E) 250	MAT(E) 315	MAT(E) 400	MAT(E) 500	MAT(E) 630	MAT(E) 800
Displacement (c.c/rev)		161.2	201.5	250.4	319.5	401.8	523.5	629	801
Max. speed (rpm)	Cont	615	615	495	375	300	235	196	154
	Int(1)	770	750	600	455	360	285	233	185
Torque (da Nm)	Cont	47	58	73	94.8	107.8	122	132.1	146.2
	Int(1)	60	71	88	113.8	125.9	137	150	152
	Peak(2)	67	83	102	133	144	159.9	162.2	166.4
Max. output (Kw)	Cont	27	34	33.5	33.4	30	26.4	18.3	15.3
	Int(1)	32	40	40	40	35	30	25.5	22.3
Max. pressure drop (bar)	Cont	200	200	200	200	180	160	140	125
	Int(1)	240	240	240	240	210	180	160	130
	Peak(2)	280	280	280	280	240	210	190	160
Max.oil flow (l/min)	Cont	100	125	125	125	125	125	125	125
	Int(1)	125	150	150	150	150	150	150	150
Max. Inlet pressure (bar)	Cont	210	210	210	210	210	210	210	210
	Int(1)	250	250	250	250	250	250	250	250
	Peak(2)	300	300	300	300	300	300	300	300
Weight(kg)		20	21	21	21.5	22	23	24	25

(1) Intermittent operation rating applies to 6 sec. of every minute

(2) Peak load rating applies to 0.6 sec of every minute

TYPE		MAT(E) 160	MAT(E) 200	MAT(E) 250	MAT(E) 315	MAT(E) 400	MAT(E) 500	MAT(E) 630	MAT(E) 800
Displacement (in.3/r)		9.5	11.9	15.3	19.5	24.5	31.9	38.4	48.9
Max. speed (rpm)	Cont	620	615	495	375	300	235	196	154
	Int(1)	775	750	600	455	360	285	233	185
Torque (lb-in)	Cont	4160	5134	6461	8390	9540	10797	11691	12939
	Int(1)	5310	6284	7788	10071	11142	12125	13275	13452
	Peak(2)	5930	7346	9027	11771	12744	14151	14355	14726
Max. output (hp)	Cont	362	25.5	44.9	44.8	40.2	35.4	24.5	20.5
	Int(1)	42.9	53.6	53.6	53.6	46.9	40.2	34.2	29.9
Max. pressure drop (psi)	Cont	2857	2857	2857	2857	2571	2286	2000	1786
	Int(1)	3428	3428	3428	3428	3000	2751	2286	1857
	Peak(2)	4000	4000	4000	4000	3428	3000	2714	2286
Max.oil flow (gpm)	Cont	26	33	33	33	33	33	33	33
	Int(1)	33	40	40	40	40	40	40	40
Max. Inlet pressure (psi)	Cont	3000	3000	3000	3000	3000	3000	3000	3000
	Int(1)	3751	3751	3751	3751	3751	3751	3751	3751
	Peak(2)	4286	4286	4286	4286	4286	4286	4286	4286
Weight(lbs)		43.9	46.2	46.3	47.4	48.5	50.7	52.91	55.12

Dimensions and Mounting Data

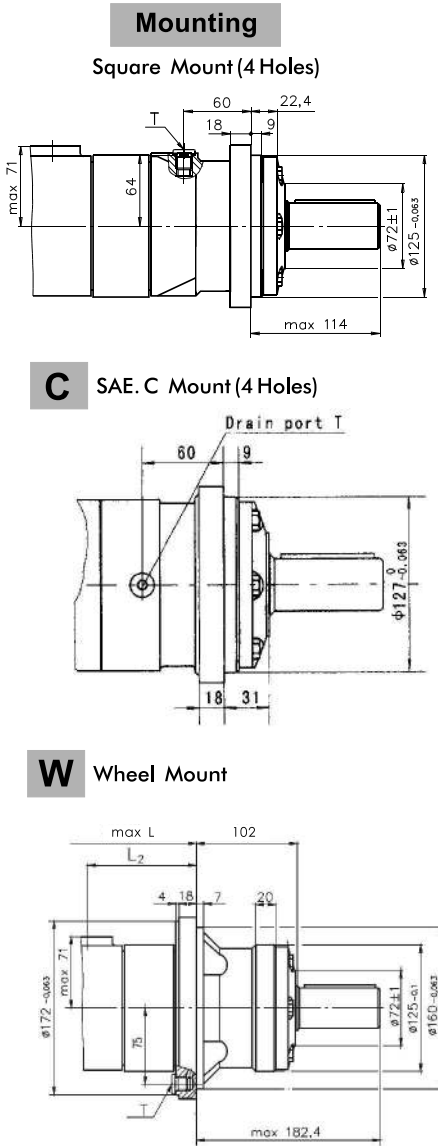
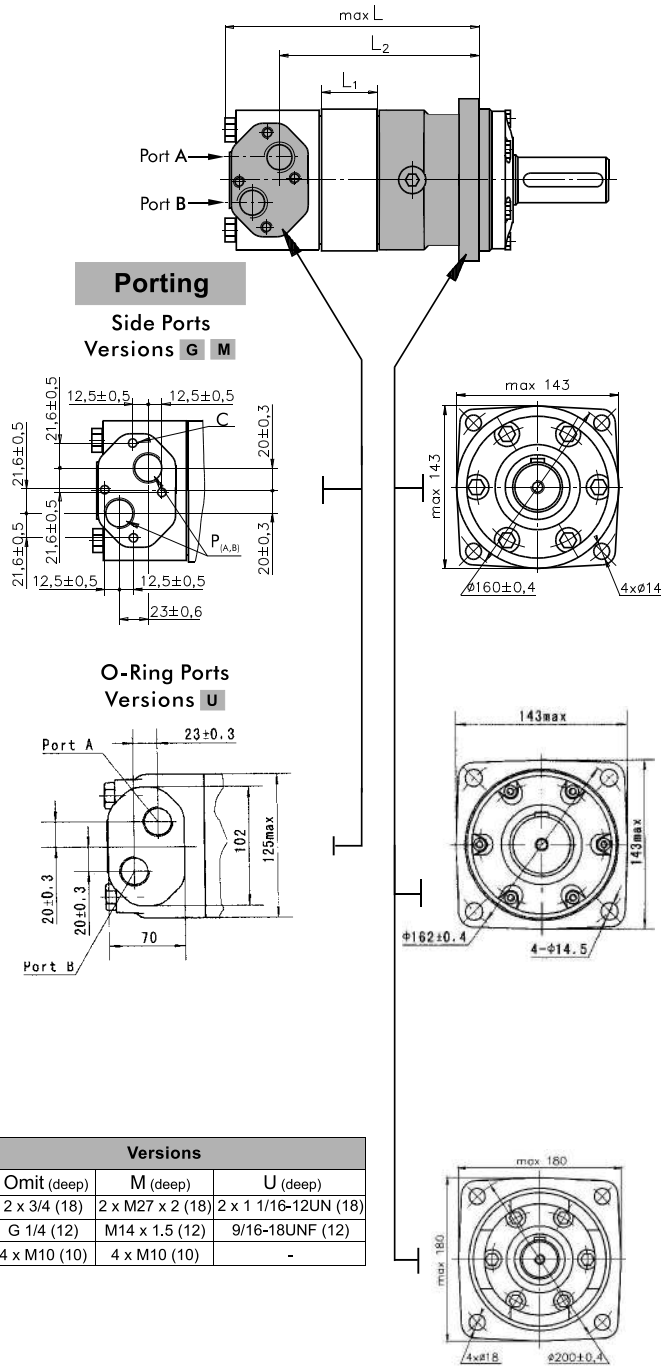

Code	Versions		
Port	Omit (deep)	M (deep)	U (deep)
P _(A,B)	2 x 3/4 (18)	2 x M27 x 2 (18)	2 x 1 1/16-12UN (18)
T	G 1/4 (12)	M14 x 1.5 (12)	9/16-18UNF (12)
C	4 x M10 (10)	4 x M10 (10)	-

Type	L	L ₂	Type	L	L ₂	L ₁
MAT 160	193	142.5	MATW 160	127	77	17
MAT 200	197	146.5	MATW 200	131	81	21
MAT 250	203	152.5	MATW 250	137	87	27
MAT 315	208	156.5	MATW 315	142	91	20
MAT 400	215	163.5	MATW 400	148	98	27
MAT 500	223	171.5	MATW 500	157	106	35
MAT 630	235	183.5	MATW 630	169	118	47
MAT 800	246	194.5	MATW 800	180	129	58

Dimensions and Mounting Data

Type	L	L ₂	L ₁
MATS 160	148	96.5	17
MATS 200	152	100.5	21
MATS 250	158	107.5	27
MATS 315	163	115	20
MATS 400	170	122	27
MATS 500	178	130	35
MATS 630	190	142	47
MATS 800	201	153	58

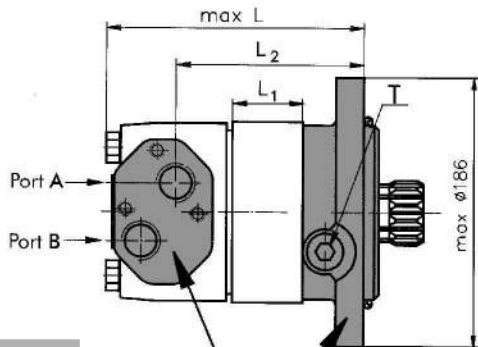

Porting
Side Ports
Versions **G M U**

Mounting

S Short Mount

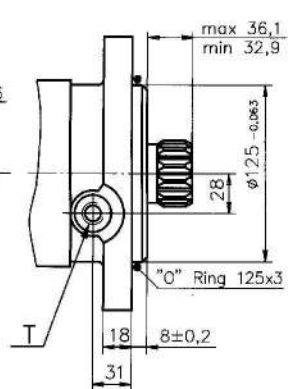
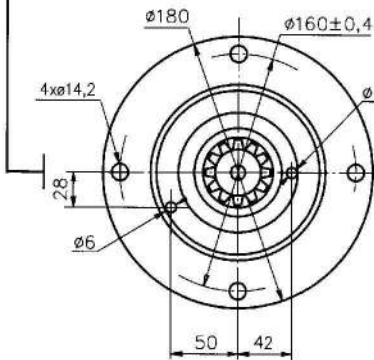
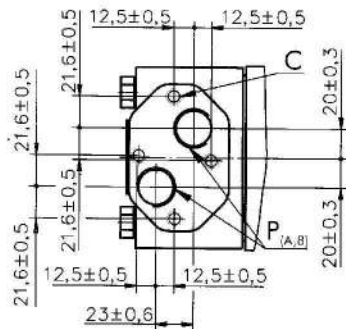

Code	Versions		
Port	Omit (deep)	M (deep)	U (deep)
P _(A,B)	2 x 3/4 (18)	2 x M27 x 2 (18)	2 x 1-1/16-12UN (18)
T	G 1/4 (12)	M14 x 1.5 (12)	9/16-18UNF (12)
C	4 x M10 (10)	4 x M10 (10)	-

Technical

The short motor has no output shaft or bearings. It is designed for direct mounting onto a gearbox that already has its female input shaft in bearings.

The cardan shaft of the short motor describes a tumbling motion. Consequently, the motor itself cannot be fitted with a shaft seal. The add-on component (gearbox) must be fitted with a leakage oil from flowing into the add-on unit.

The maximum permissible back flow pressure (pressure in the motor leakage oil line) is dependent on the loading capacity of the shaft seal. We always recommend fitting a leakage oil line.

The gearbox input must be designed so the leakage oil from the motor lubricates the cardan shaft profile and the bearings.

Route the leakage oil line so lubrication to the motor is still assured when it stopped. Use the tapered sealing ring supplied with the motor in order to direct the leakage oil to the lubrication.

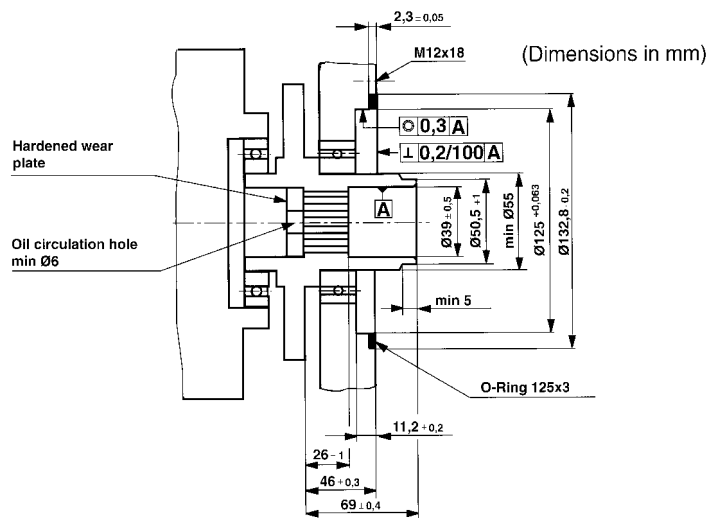

Internal Spline Data for The Attached Component

Fillet Root Side Fit	mm	
Number of Teeth	z	16
Diametral Pitch	DP	12/24
Pressure Angle		30°
Pitch Dia.	D	33.8656
Major Dia.	D ₁	38.4 ^{+0.4}
Minor Dia.	D ₂	32.15 ^{+0.24}
Space Width [Circular]	L ₀	4.516 ± 0.021

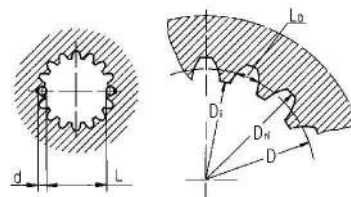

Hardening Specification:
HRC 60 ± 2
0,7 ± 0,2 mm effective case depth

Dimensions and Mounting Data

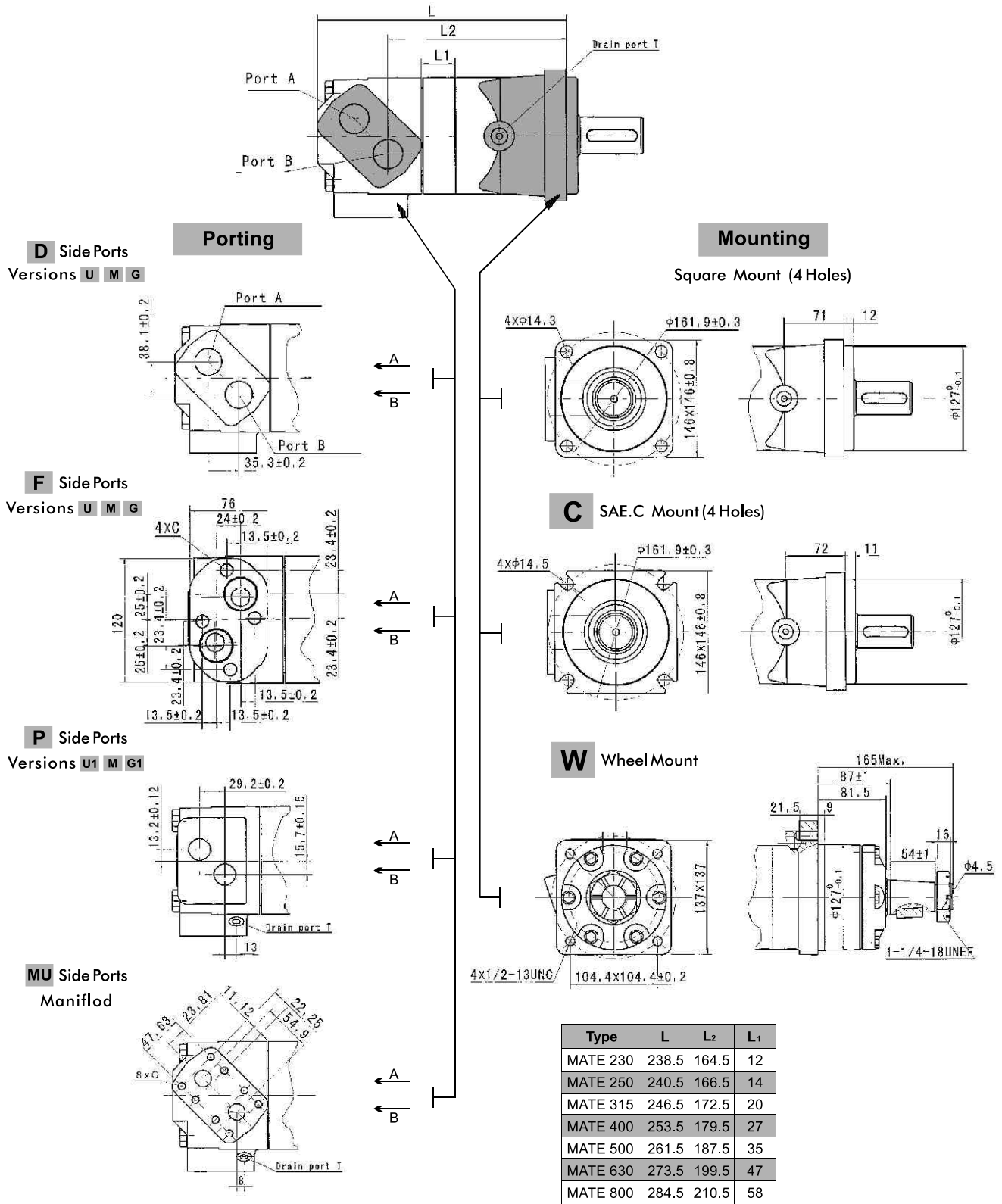

Dimensions and Mounting Data

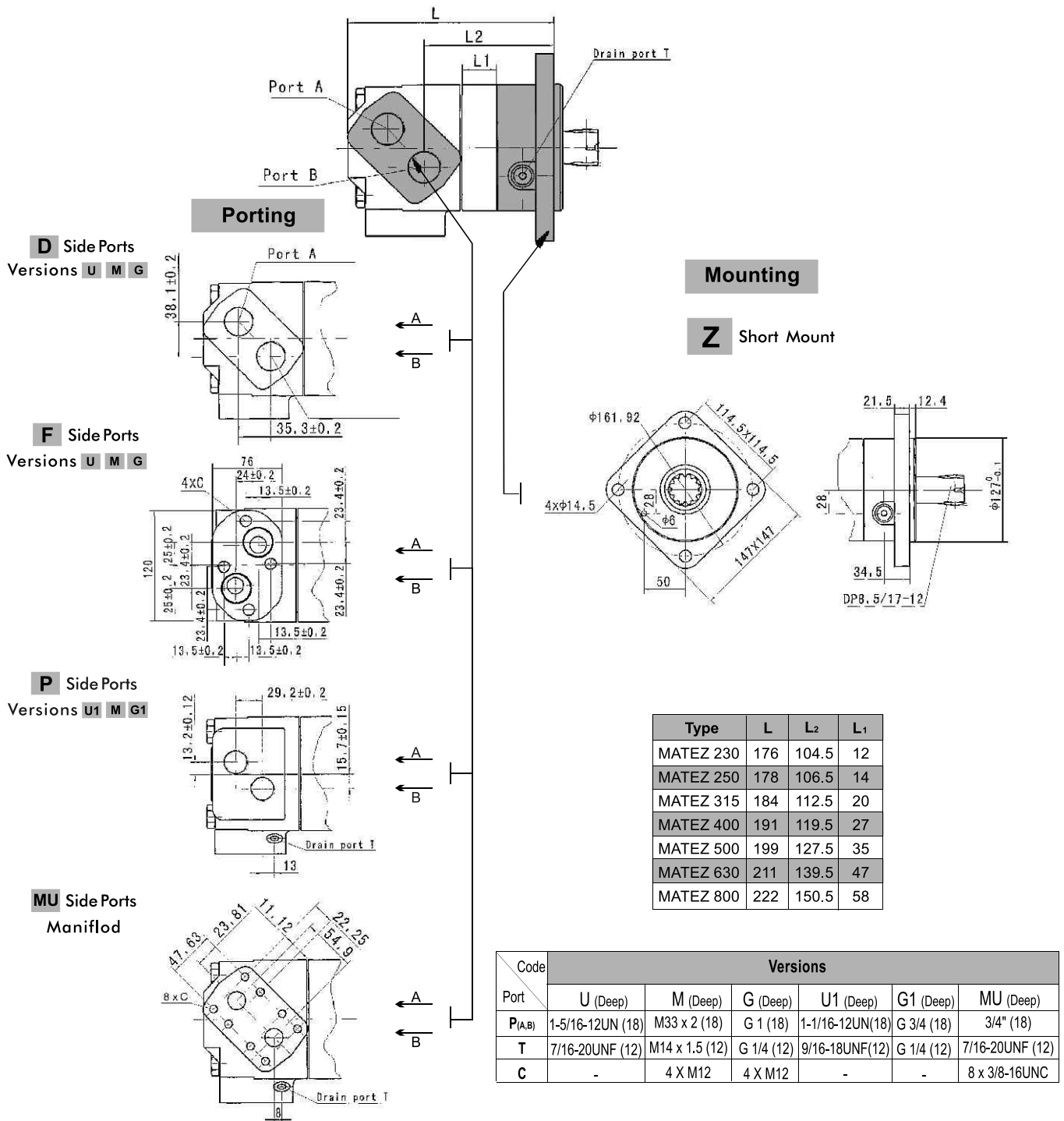

Internal Spline Data for The Attached Component

Fillet Root Side Fit	mm
Number of Tech	z 12
Diametral Pitch	DP 8.5/17
Pressure Angle	30°
Pitch Dia.	D 35,858823
Major Dia.	Dri 38,94 ^{+0.2}
Minor Dia.	Di 33,3 ^{+0.18}
Space Width [Circular]	Lo 5,866 ± 0,032
Dimension between two pins (ø4)	Me 26,929-27,84

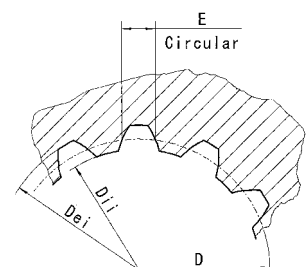
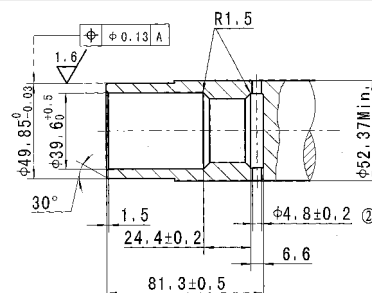

Shaft Extensions for MAT & MATE Motor

C - ϕ 40 straight, Parallel key A12x8x70 DIN 6885
Max. Torque 132,8 daNm

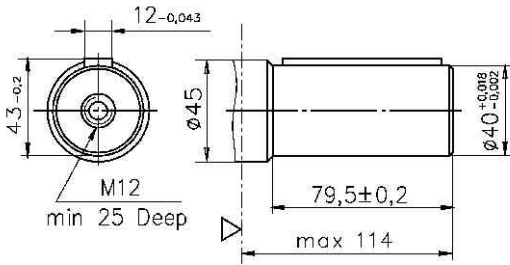

K -tapered 1:10, Parallel key B12x8x28 DIN 6885
Max. Torque 210,7 daNm

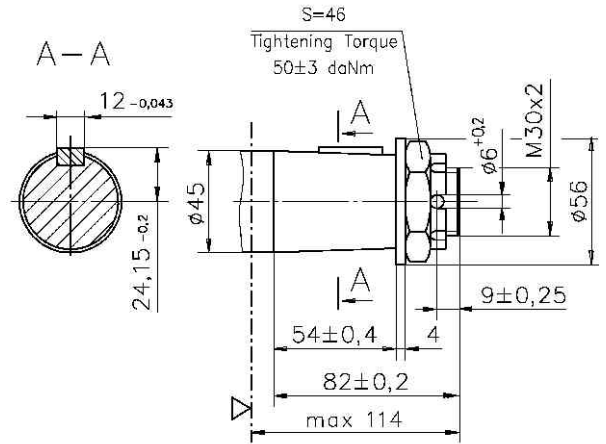

CO - ϕ 1 1/2" straight, Parallel key 3/8"x 3/8"x 2 1/4" BS46
Max. Torque 132,8 daNm

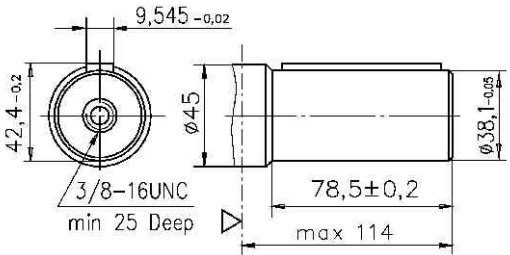

SH - ϕ 1 1/2" splined 17T, DP 12/24 ANSI B92.1-1976
Max. Torque 132,8 daNm

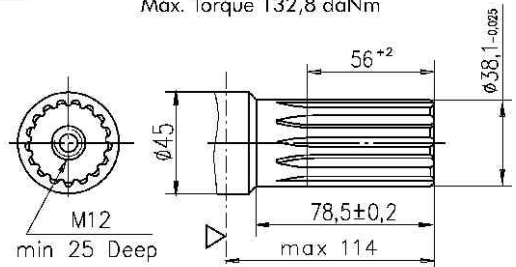

SL 6-34.85 P.T.O. Splined
Max. Torque 77 daNm

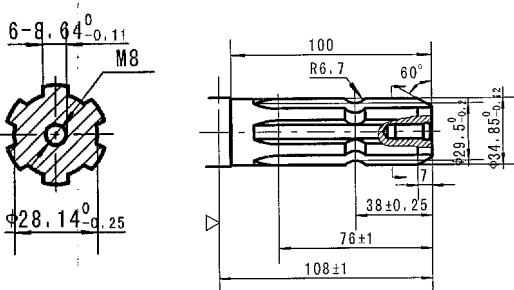

SB ϕ 31.75 [1 1/4]" Splined 14T, DP 12/24
Max. Torque 95 daNm

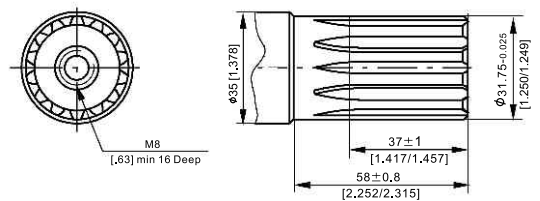

Shaft Loads

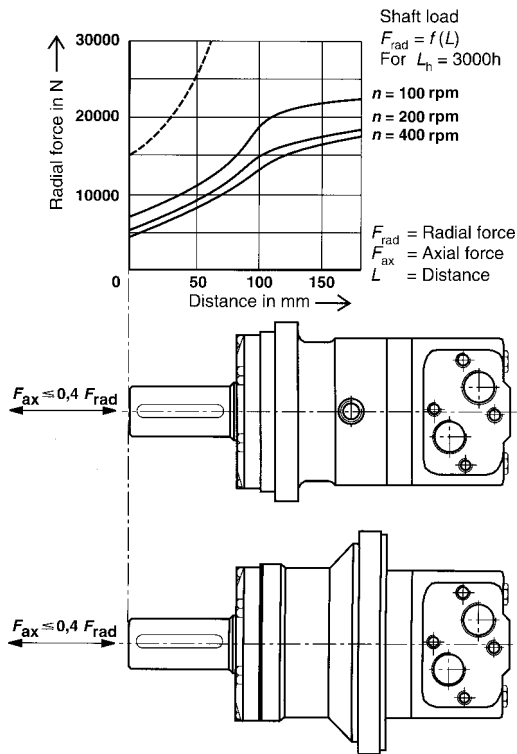

The tapered roller bearings on the output shaft mean it can accept high levels of axial and radial shaft load. The broken curve plots the maximum permissible radial load. Loads above and beyond this level can lead to breakage. The central solid curves plot the permissible radial loads for a theoretical service life (B10) of 3000 hours at 200 rpm. The expected service life can be calculated for different speeds and/or radial loads. This data assumes the use of a hydraulic fluid with a sufficient anti-wear additive content.

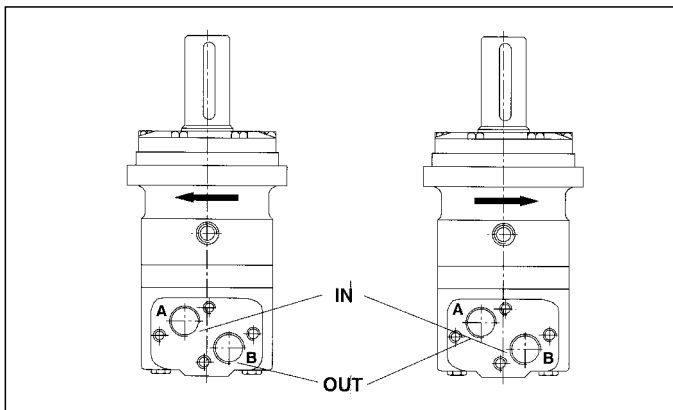

Rotation Selection

The MAT has built-in check valves. The pressure on the shaft seal is never greater than back flow pressure because of the built-in check valves. In the short motor, pressure is determined based on the technical data of the add-on components.

Max. return pressure without drain line or/ Max. pressure in drain line

rpm	Cont. (bar)
0 - 100 rpm	75
100 - 300 rpm	40
300 - 810 rpm	20

Max. return pressure with drain line

Continuous	140 bar
Intermittent	175 bar

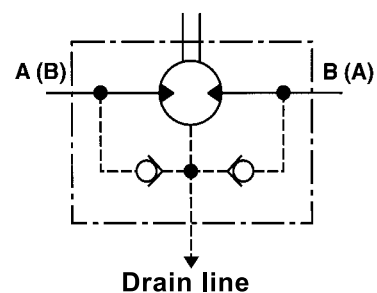

	1	2	3	4	5	6
MAT						

Pos.1 Mounting Flange

Omit - Square Mount (4 holes)

- C** - SAE. C Mount (4 holes)
- W** - Wheel Mount
- S** - Short Mount

Pos.2 Displacement Code

- 160** - 161.2cc/9.5 [in.3/r]
- 200** - 201.5cc/11.9 [in.3/r]
- 250** - 250.4cc/15.3 [in.3/r]
- 315** - 319.5cc/19.5 [in.3/r]
- 400** - 401.8cc/24.5 [in.3/r]
- 500** - 523.5cc/31.9 [in.3/r]
- 630** - 629.0cc/38.4 [in.3/r]
- 800** - 801.0cc/48.9 [in.3/r]

Pos.3 Shaft Extensions

- C** - ϕ 40 Straight, Parallel key A12 x 8 x 70
- CO** - ϕ 1 1/2" Straight, Parallel key 3/8" x 3/8" x 2 1/4"
- K** - Tapered 1:10, Parallel key B12 x 8 x 28
- SH** - ϕ 1 1/2" Splined 17T
- SL** - 6-34.85 P.T.O. Splined
- SB** - ϕ 31.75[1 1/4]" Splined 14T, DP 12/24

Pos.4 Porting

- Omit - G3/4
- M** - Metric
- U** - 2 x 1 1/16 - 12UN T : 9/16-18UNF

Pos.5 Painting

- Omit - Grey
- B** - Black
- 00** - No Paint

Pos.6 Rotation

- Omit - Standard Rotation
- R** - Reverse Rotation

	1	2	3	4	5	6	7
MATE							

Pos.1 Mounting Flange

Omit - Square Mount (4 holes)

- C** - SAE. C Mount (4 holes)
- W** - Wheel Mount
- Z** - Short Mount

Pos.2 Port Type

- D** - Side Ports
- F** - Side Ports
- P** - Side Ports
- MU** - Omit

Pos.3 Displacement Code

- 160** - 161.2cc/9.5 [in.3/r]
- 200** - 201.5cc/11.9 [in.3/r]
- 250** - 250.4cc/15.3 [in.3/r]
- 315** - 319.5cc/19.5 [in.3/r]
- 400** - 401.8cc/24.5 [in.3/r]
- 500** - 523.5cc/31.9 [in.3/r]
- 630** - 629.0cc/38.4 [in.3/r]
- 800** - 801.0cc/48.9 [in.3/r]

Pos.4 Shaft Extensions

- C** - ϕ 40 Straight, Parallel key A12 x 8 x 70
- CO** - ϕ 1 1/2" Straight, Parallel key 3/8" x 3/8" x 2 1/4"
- K** - Tapered 1:10, Parallel key B12 x 8 x 28
- SH** - ϕ 1 1/2" Splined 17T
- SL** - 6-34.85 P.T.O. Splined
- SB** - ϕ 31.75[1 1/4]" Splined 14T, DP 12/24

Pos.5 Porting

- U** - 2 x 1 5/16 - 12UN T : 7/16-20UNF
- M** - 2 x M33 x 2 T : M14 x 1.5 C : 4 x M12
- G** - 2 x G 1 T : 1/4
- U1** - 2 x 1 1/16 - 12UN T : 9/16-18UNF
- G1** - 2 x G 3/4 T : 1/4
- MU** - 2 x 3/4" T : 7/16-20UNF C : 8 x 3/8-16UNC

Pos.6 Painting

- Omit - Grey
- B** - Black
- 00** - No Paint

Pos.7 Rotation

- Omit - Standard Rotation
- R** - Reverse Rotation