

VALVOLE DI BLOCCO PILOTATE
A SEMPLICE EFFETTO

SINGLE PILOT OPERATED
CHECK VALVES

2





2.1 - VALVOLE DI BLOCCO PILOTATE A SEMPLICE EFFETTO A 4 VIE

TIPO/TYPE
VBPSE

2.1 - SINGLE PILOT OPERATED CHECK VALVES



SCHEMA IDRAULICO
HYDRAULIC DIAGRAM

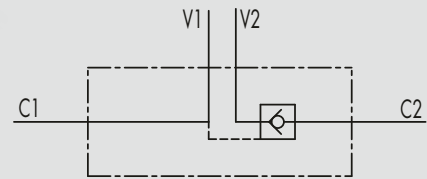

IMPIEGO:

Valvola utilizzata per bloccare in posizione un cilindro in un solo senso, consentendo il flusso in una direzione ed impedendolo in senso contrario fino a quando non viene applicata la pressione di pilotaggio.

MATERIALI E CARATTERISTICHE:

Corpo: acciaio zincato

Componenti interni: acciaio temprato termicamente e rettificato

Guarnizioni: BUNA N standard

Tenuta: a cono guidato. Non ammette trafilamenti

MONTAGGIO:

Collegare V1 e V2 all'alimentazione, C1 al lato dell'attuatore con flusso libero e C2 al lato dell'attuatore dove si desidera la tenuta.

A RICHIESTA:

- senza guarnizione OR sul pilota
- molla 1 Bar
- molla 8 Bar

USE AND OPERATION:

These valves are used to block the cylinder in one direction. The flow is free in one direction and blocked in the reverse direction until pilot pressure is applied.

MATERIALS AND FEATURES:

Body: zinc-plated steel

Internal parts: hardened and ground steel

Seals: BUNA N standard

Poppet type: any leakage.

APPLICATIONS:

Connect V1 and V2 to the pressure flow, C1 to the free flow side of the actuator and C2 to the actuator's side you want the flow to be blocked.

ON REQUEST:

- without seal on pilot piston
- 1 Bar spring
- 8 Bar spring

PERDITE DI CARICO PRESSURE DROPS CURVE

Temperatura olio: 50°C - Viscosità olio: 30 cSt
Oil temperature: 50°C - Oil viscosity: 30 cSt

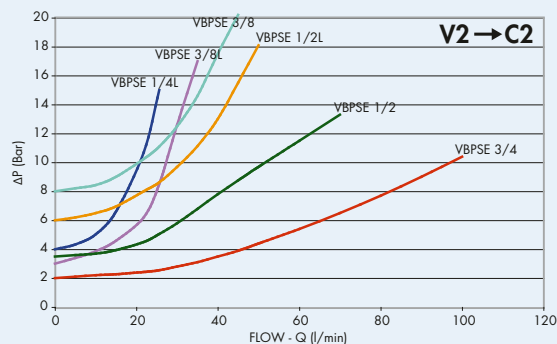
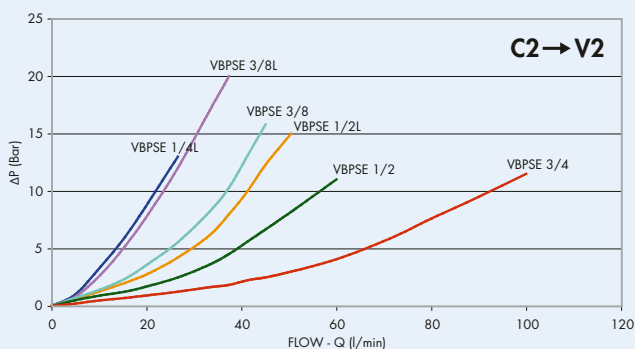



CODICE CODE	SIGLA TYPE	RAPP.PILOT. PILOT RATIO	PORTATA MAX MAX FLOW Lt./min	PRESSIONE MAX MAX PRESSURE Bar	PRESSIONE APERTURA CRACKING PRESSURE Bar
V0220	VBPSE 1/4" L 4 VIE	1 : 5,5	20	350	4
V0230	VBPSE 3/8" L 4 VIE	1 : 5,5	35	350	3
V0240	VBPSE 1/2" L 4 VIE	1 : 5	50	350	6
V0250	VBPSE 3/8" 4 VIE	1 : 5	45	350	8
V0260	VBPSE 1/2" 4 VIE	1 : 4	70	350	3,5
V0245	VBPSE 3/4" 4 VIE	1 : 4	100	350	2

DXF

2

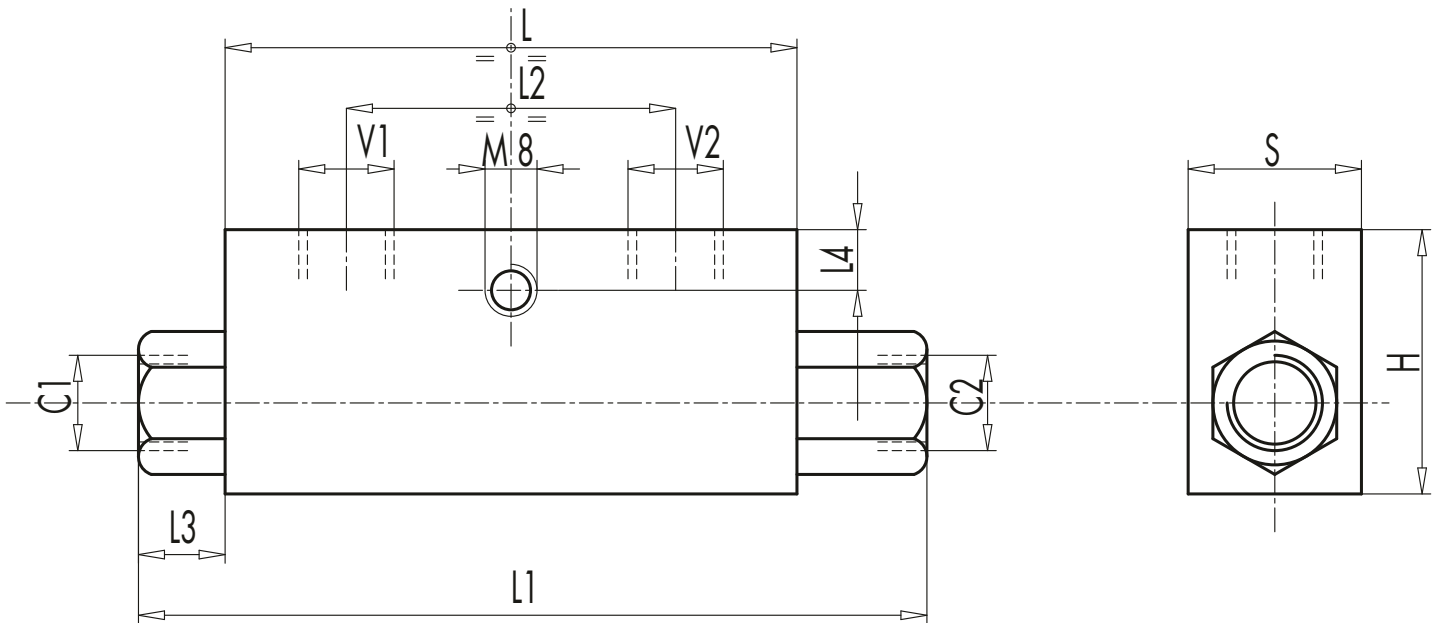

CODICE CODE	SIGLA TYPE	V1-V2 C1-C2	L	L1	L2	L3	L4	H	S	PESO WEIGHT
		GAS	mm	mm	mm	mm	mm	mm	mm	Kg
V0220	VBPSE 1/4" L 4 VIE	G 1/4"	64	106,5	36	18,5	8	40	30	0,612
V0230	VBPSE 3/8" L 4 VIE	G 3/8"	80	120	38	16	8	40	30	0,706
V0240	VBPSE 1/2" L 4 VIE	G 1/2"	90	133	45	17	8	45	35	0,994
V0250	VBPSE 3/8" 4 VIE	G 3/8"	90	148	45	25	8	45	35	1,130
V0260	VBPSE 1/2" 4 VIE	G 1/2"	80	134	40	23	18	60	35	1,214
V0245	VBPSE 3/4" 4 VIE	G 3/4"	100	182	48	36	8	60	40	1,792





2.2 - VALVOLE DI BLOCCO PILOTATE A SEMPLICE EFFETTO CON CARTUCCE EXTRACORTE DIN 2353

TIPO/TYPE
VBPSE 2 CEXC

2.2 - SINGLE PILOT OPERATED CHECK VALVES FOR 12 mm PIPE MOUNTING (DIN 2353)

SCHEMA IDRAULICO
HYDRAULIC DIAGRAM

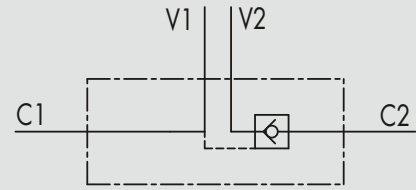

IMPIEGO:

Valvola utilizzata per bloccare in posizione un cilindro in un solo senso, consentendo il flusso in una direzione ed impedendolo in senso contrario fino a quando non viene applicata la pressione di pilotaggio. Questa valvola risulta particolarmente adatta per il montaggio su cilindro. A richiesta si fornisce kit raccordi a misura per il montaggio a interasse definito.

MATERIALI E CARATTERISTICHE:

Corpo: acciaio zincato
Componenti interni: acciaio temprato termicamente e rettificato
Guarnizioni: BUNA N standard
Tenuta: a cono guidato. Non ammette trafilamenti

MONTAGGIO:

Collegare V1 e V2 all'alimentazione, C1 al lato dell'attuatore con flusso libero e C2 al lato dell'attuatore dove si desidera la tenuta.

A RICHIESTA:

- senza guarnizione OR sul pilota
- senza dado e ogiva
- molla 1 Bar
- molla 8 Bar

USE AND OPERATION:

These valves are used to block the cylinder in one direction. The flow is free in one direction and blocked in the reverse direction until pilot pressure is applied. They are easily assembled on cylinders. Specific distance-centre mounting fittings kit on request.

MATERIALS AND FEATURES:

Body: zinc-plated steel.
Internal parts: hardened and ground steel.
Seals: BUNA N standard
Poppet type: any leakage.

APPLICATIONS:

Connect V1 and V2 to the pressure flow, C1 to the free flow side of the actuator and C2 to the actuator's side you want the flow to be blocked.

ON REQUEST:

- without seal on pilot piston
- without nut and olive
- 1 Bar spring
- 8 Bar spring

PERDITE DI CARICO PRESSURE DROPS CURVE

Temperatura olio: 50°C - Viscosità olio: 30 cSt
Oil temperature: 50°C - Oil viscosity: 30 cSt

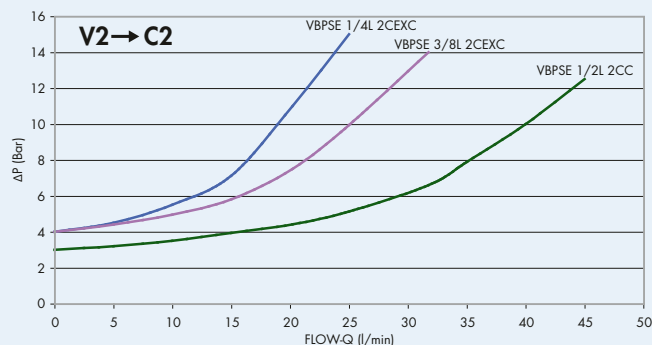
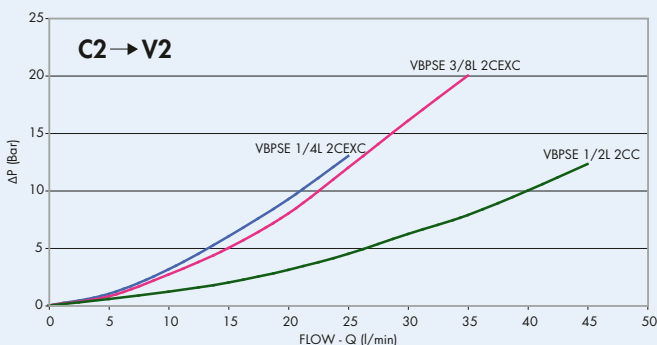



CODICE CODE	SIGLA TYPE	RAPP.PILOT. PILOT RATIO	PORTATA MAX MAX FLOW Lt./min	PRESSIONE MAX MAX PRESSURE Bar	PRESSIONE APERTURA CRACKING PRESSURE Bar
V0090/SE	VBPSE 1/4" L 2 CEXC	1 : 5,5	20	350	4
V0110/SE	VBPSE 3/8" L 2 CEXC	1 : 5,5	30	350	4
V0135/SE	VBPSE 1/2" L 2 CC	1 : 5	50	350	3

DXF

2

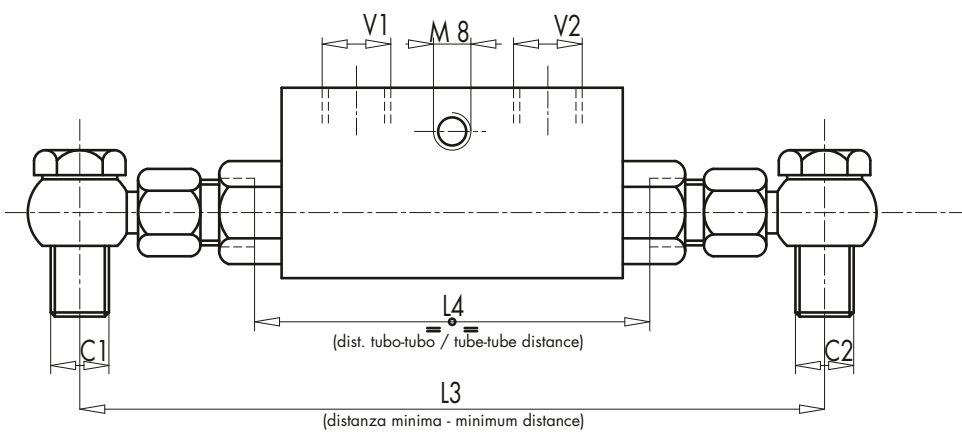
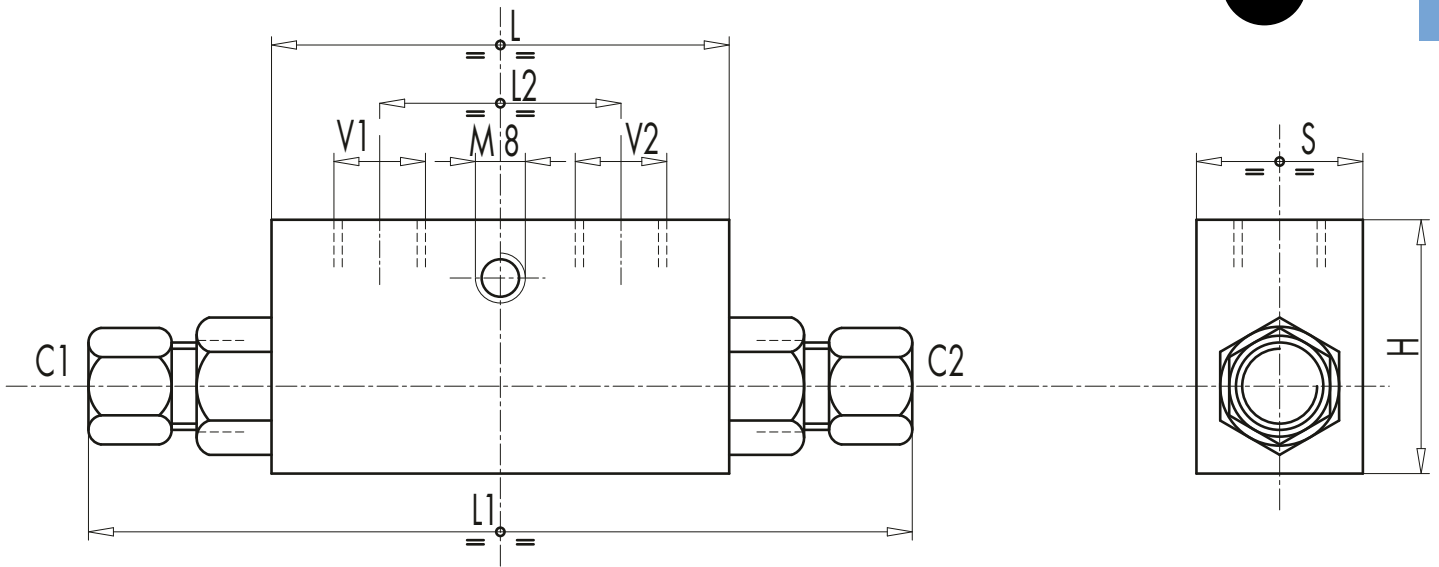

CODICE CODE	SIGLA TYPE	V1-V2	C1-C2	L	L1	L2	L3	L4	H	S	PESO WEIGHT
		GAS	mm	mm	mm	mm	mm	mm	mm	mm	Kg
V0090/SE	VBPSE 1/4" L 2 CEXC	G 1/4"	12L	64	134	36	160	84	40	30	0,638
V0110/SE	VBPSE 3/8" L 2 CEXC	G 3/8"	12L	64	134	36	166	84	40	30	0,620
V0135/SE	VBPSE 1/2" L 2 CC	G 1/2"	15L	90	164	45	196	106	45	35	1,088





2.3 - VALVOLE DI BLOCCO PILOTATE A SEMPLICE EFFETTO A 3 VIE IN LINEA

2.3 - 3 WAYS SINGLE PILOT OPERATED CHECK VALVES, IN LINE

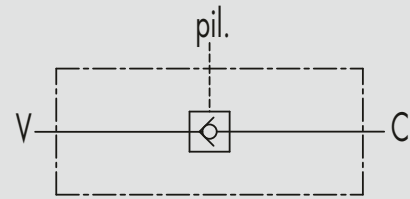
TIPO / TYPE
VBPSLSCHEMA IDRAULICO
HYDRAULIC DIAGRAM**IMPIEGO:**

Valvola utilizzata per bloccare in posizione un cilindro in un solo senso, consentendo il flusso in una direzione ed impedendolo in senso contrario fino a quando non si applica la pressione di pilotaggio. È realizzata per il montaggio in linea, pertanto può essere montata in qualsiasi posizione.

MATERIALI E CARATTERISTICHE:

Corpo: acciaio zincato.

Componenti interni: acciaio temprato termicamente e rettificati.

Guarnizioni: BUNA N

Tenuta: a cono guidato. Non ammette trafilamenti.

MONTAGGIO:

Collegare V all'alimentazione, C all'attuatore dove si desidera la tenuta e Pil. alla linea di pilotaggio.

A RICHIESTA:

- molla 8 Bar

USE AND OPERATION:

These valves are used to block the cylinder in one direction. The flow is free in one direction and blocked in the reverse direction until pilot pressure is applied.

MATERIALS AND FEATURES:

Body: yellow-plated steel.

Internal parts: hardened and ground steel.

Seals: BUNA N standard

Poppet type: any leakage.

APPLICATIONS:

Connect V to the pressure flow, C to the actuator's side you want the flow to be blocked and Pil to the pilot line.

ON REQUEST:

- 8 Bar spring

PERDITE DI CARICO PRESSURE DROPS CURVE

Temperatura olio: 50°C - Viscosità olio: 30 cSt
Oil temperature: 50°C - Oil viscosity: 30 cSt

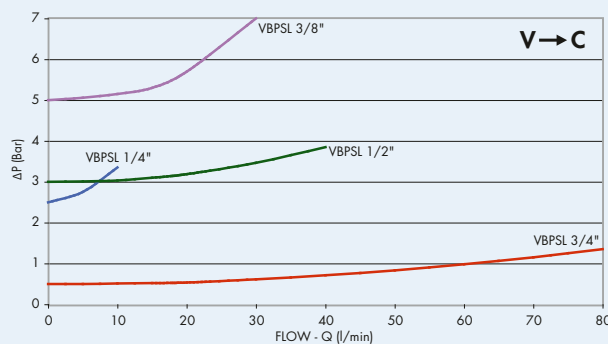
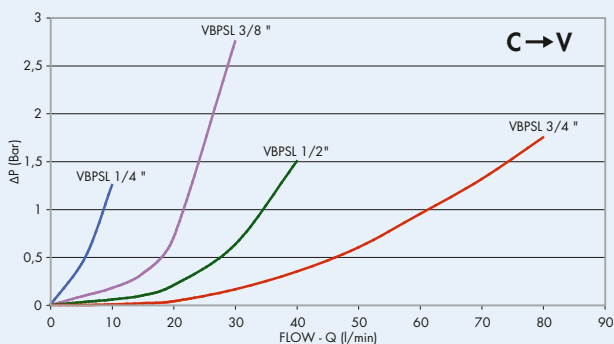



CODICE CODE	SIGLA TYPE	RAPP.PILOT. PILOT RATIO	PORTATA MAX MAX FLOW Lt./min	PRESSIONE MAX MAX PRESSURE Bar	PRESSIONE APERTURA CRACKING PRESSURE Bar
V0201	VBPSL 1/4"	1 : 9,8	15	350	2,5
V0202	VBPSL 3/8"	1 : 6,5	30	300	5
V0203	VBPSL 1/2"	1 : 4,6	45	300	3
V0204	VBPSL 3/4"	1 : 4,4	80	250	0,5

DXF

2

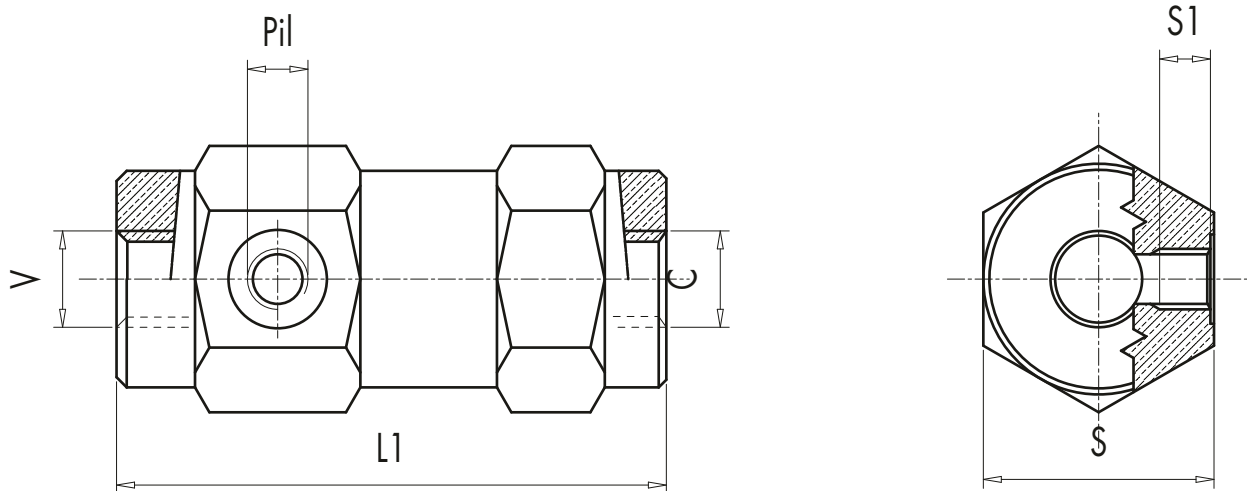

CODICE CODE	SIGLA TYPE	V - C	Pil.	L1	S	S1	PESO WEIGHT
		GAS	GAS	mm	mm	mm	Kg
V0201	VBPSL 1/4"	G 1/4"	G 1/4"	103	36	11	0,690
V0202	VBPSL 3/8"	G 3/8"	G 1/4"	109	40	11,5	0,900
V0203	VBPSL 1/2"	G 1/2"	G 1/4"	120	42	11	1,040
V0204	VBPSL 3/4"	G 3/4"	G 1/4"	131	55	14	2,300





2.4 - VALVOLE DI BLOCCO A SEMPLICE EFFETTO A 3 VIE AD ALTO PILOTAGGIO

TIPO/TYPE
VBL/3

2.4 - SINGLE PILOT OPERATED CHECK VALVES, HIGH PILOT



SCHEMA IDRAULICO
HYDRAULIC DIAGRAM

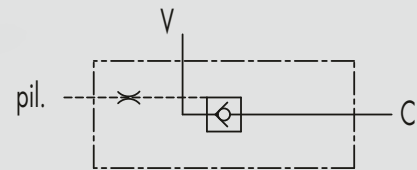

IMPIEGO:

Valvola utilizzata per bloccare in posizione un cilindro, consentendo il flusso in una direzione ed impedendolo in senso contrario fino a quando non viene applicata la pressione di pilotaggio. Queste valvole, caratterizzate da un alto rapporto di pilotaggio e da un sistema che ne ritarda la chiusura, sono particolarmente adatte per circuiti dove siano presenti carichi pesanti per evitare le vibrazioni.

ATTENZIONE: in caso di impiego con distributore ed elettrovalvole con utilizzi aperti interpellare il costruttore.

MATERIALI E CARATTERISTICHE:

Corpo: acciaio zincato

Componenti interni: acciaio temprato termicamente e rettificato

Guarnizioni: BUNA N standard

Tenuta: a cono guidato. Non ammette trafilamenti

MONTAGGIO:

Collegare V all'alimentazione, C all'attuatore dove si desidera la tenuta e pil. alla linea di pilotaggio.

A RICHIESTA:

- molla 1 Bar
- molla 8 Bar

USE AND OPERATION:

These valves are used to block the cylinder in one direction. The flow is free in one direction and blocked in the reverse direction until pilot pressure is applied. Thanks to its high pilot ratio and to a time-lag locking device, it's suitable to avoid vibrations in circuits with heavy loads.

WARNING: please ask the producer for use with distributors or open centre solenoid valves.

MATERIALS AND FEATURES:

Body: zinc-plated steel

Internal parts: hardened and ground steel

Seals: BUNA N standard

Poppet type: any leakage.

APPLICATIONS:

Connect V to the pressure flow, C to the actuator's side you want the flow to be blocked and Pil to the pilot line.

ON REQUEST:

- 1 Bar spring
- 8 Bar spring

PERDITE DI CARICO PRESSURE DROPS CURVE

Temperatura olio: 50°C - Viscosità olio: 30 cSt
Oil temperature: 50°C - Oil viscosity: 30 cSt

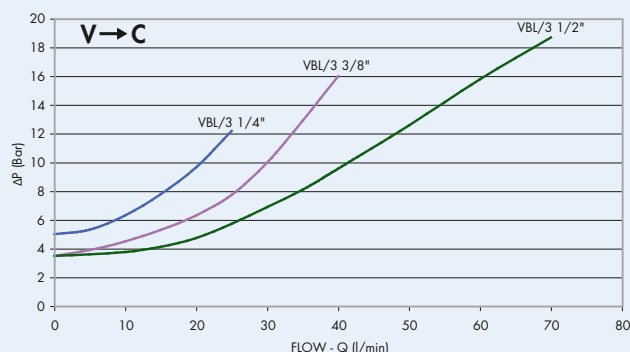
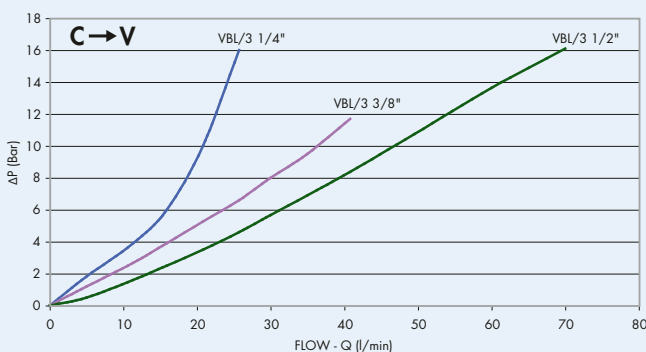



CODICE CODE	SIGLA TYPE	RAPP.PILOT. PILOT RATIO	PORTATA MAX MAX FLOW Lt./min	PRESSIONE MAX MAX PRESSURE Bar	PRESSIONE APERTURA CRACKING PRESSURE Bar
V0273	VBL/3 SE 1/4"	1 : 8	20	350	4
V0275	VBL/3 SE 3/8"	1 : 8	40	350	3,5
V0277	VBL/3 SE 1/2"	1 : 7	70	350	3,5

DXF

2

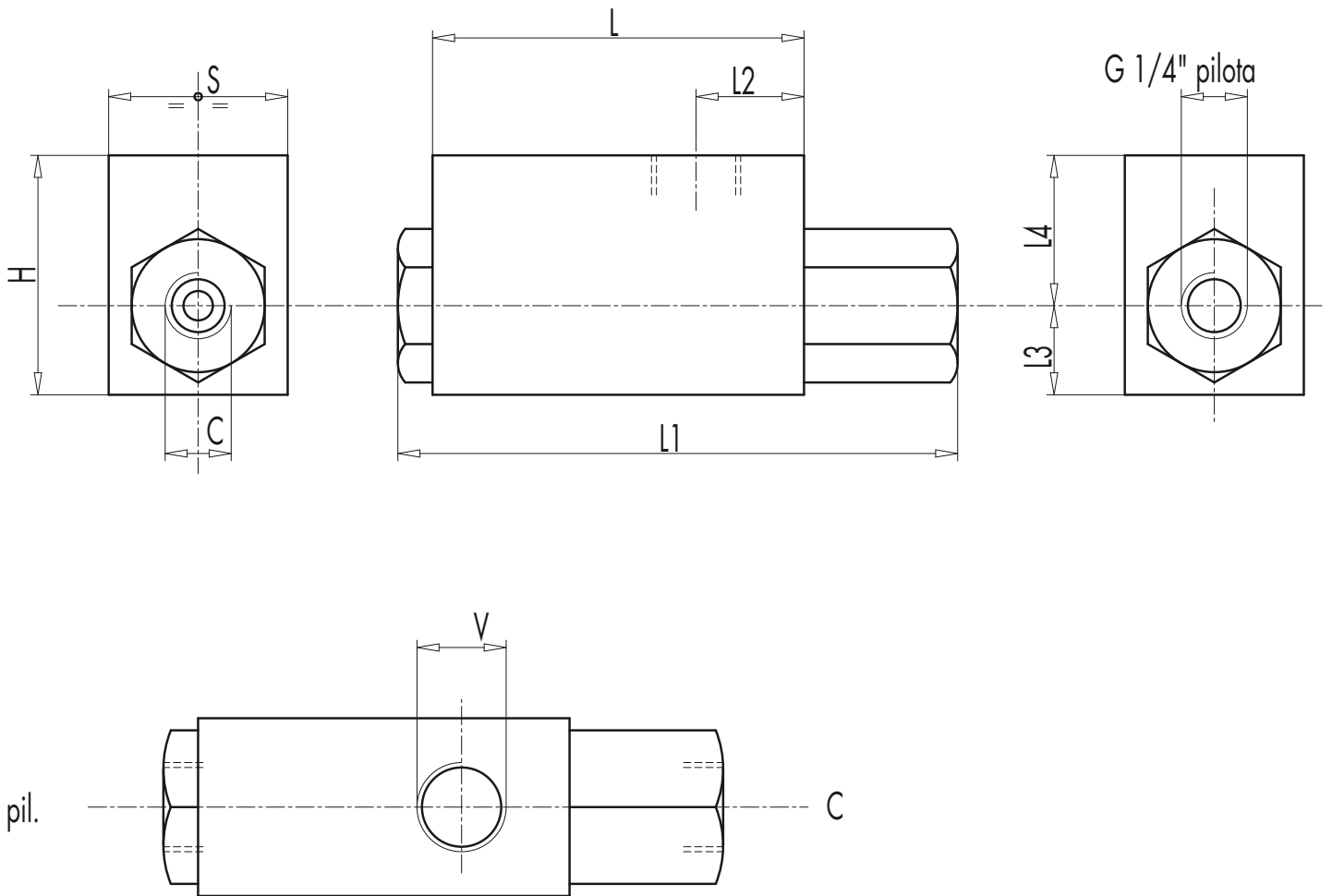

CODICE CODE	SIGLA TYPE	V-C	L	L1	L2	L3	L4	H	S	PESO WEIGHT
		GAS	mm	mm	mm	mm	mm	mm	mm	Kg
V0273	VBL/3 SE 1/4"	G 1/4"	70	104	22	15	25	40	30	0,668
V0275	VBL/3 SE 3/8"	G 3/8"	80	120	24	18	30	48	35	1,064
V0277	VBL/3 SE 1/2"	G 1/2"	80	120	26	20	32	52	40	1,280





2.5 - VALVOLE DI BLOCCO A SEMPLICE EFFETTO A 4 VIE TIPO A

2.5 - SINGLE PILOT OPERATED CHECK VALVES TYPE A

TIPO/TYPE
VBPSE A



SCHEMA IDRAULICO
HYDRAULIC DIAGRAM

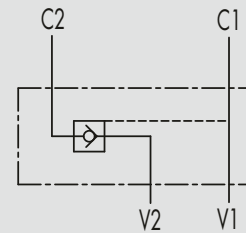

IMPIEGO:

Valvola utilizzata per bloccare in posizione un cilindro in un solo senso, consentendo il flusso in una direzione ed impedendolo in senso contrario fino a quando non viene applicata la pressione di pilotaggio.

MATERIALI E CARATTERISTICHE:

Corpo: acciaio zincato

Componenti interni: acciaio temprato termicamente e rettificato

Guarnizioni: BUNA N standard

Tenuta: a cono guidato. Non ammette trafilamenti

MONTAGGIO:

Collegare V1 e V2 all'alimentazione, C1 al lato dell'attuatore con flusso libero e C2 al lato dell'attuatore dove si desidera la tenuta.

A RICHIESTA:

- senza guarnizione OR sul pilota
- molla 1 Bar
- molla 8 Bar

USE AND OPERATION:

These valves are used to block the cylinder in one direction. Flow is free in one direction and blocked in the reverse direction until pilot pressure is applied.

MATERIALS AND FEATURES:

Body: zinc-plated steel.

Internal parts: hardened and ground steel

Seals: BUNA N standard

Poppet type: any leakage.

APPLICATIONS:

Connect V1 and V2 to the pressure flow, C1 to the free flow side of the actuator and C2 to the actuator's side you want the flow to be blocked.

ON REQUEST

- without seal on pilot piston
- 1 Bar spring
- 8 Bar spring

PERDITE DI CARICO PRESSURE DROPS CURVE

Temperatura olio: 50°C - Viscosità olio: 30 cSt
Oil temperature: 50°C - Oil viscosity: 30 cSt

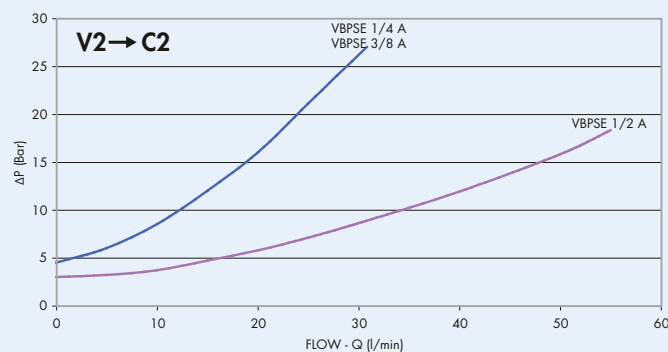
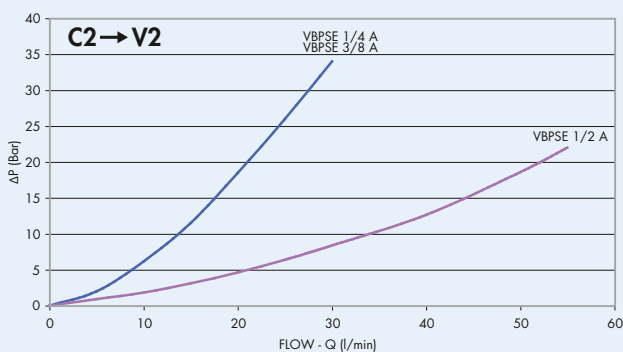



CODICE CODE	SIGLA TYPE	RAPP.PILOT. PILOT RATIO	PORTATA MAX MAX FLOW Lt./min	PRESSIONE MAX MAX PRESSURE Bar	PRESSIONE APERTURA CRACKING PRESSURE Bar
V0272	VBPSE 1/4" A	1 : 5,5	20	350	4,5
V0274	VBPSE 3/8" A	1 : 5,5	30	350	4,5
V0276	VBPSE 1/2" A	1 : 4,5	55	350	3

DXF

2

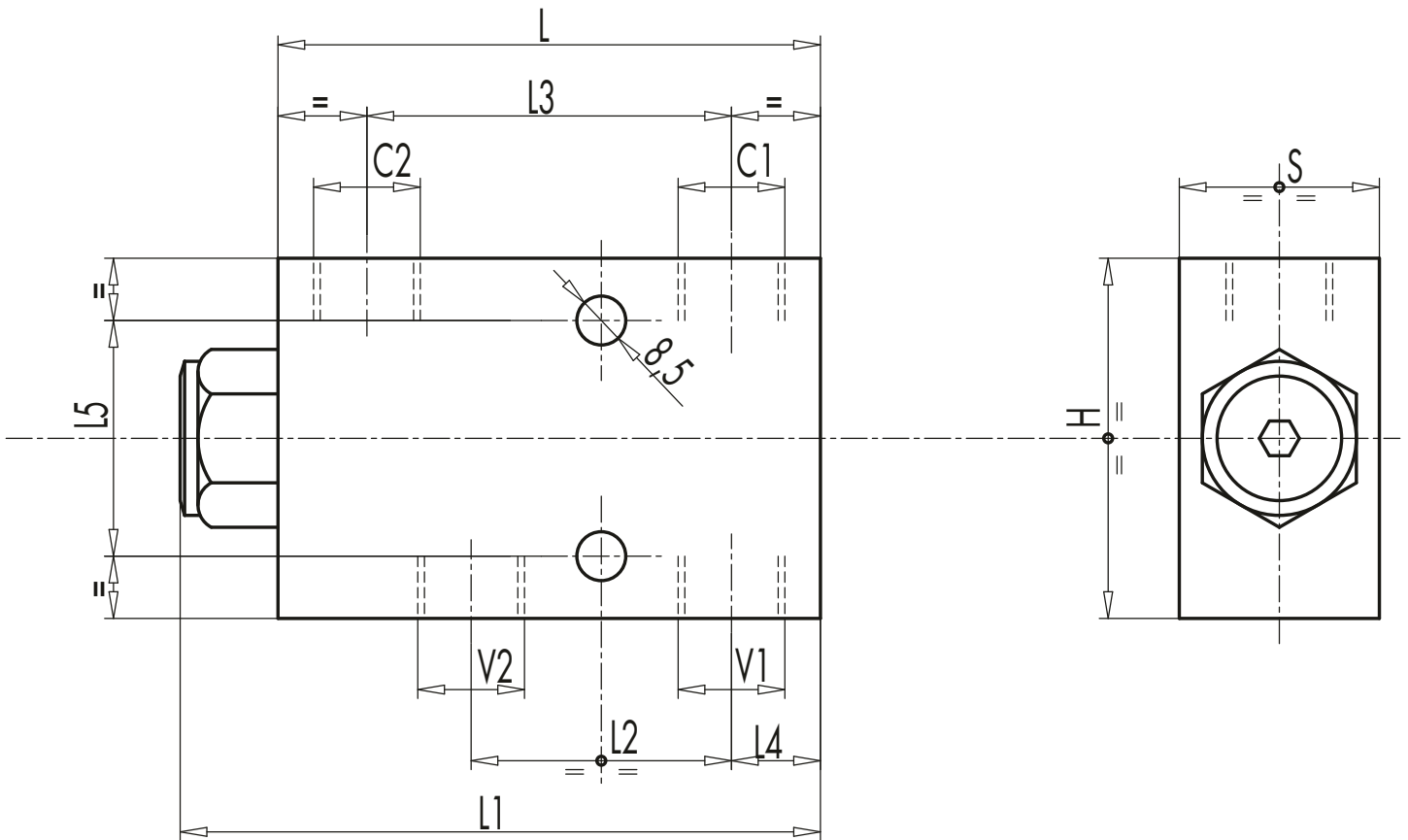

CODICE CODE	SIGLA TYPE	V1-V2 C1-C2	L	L1	L2	L3	L4	L5	H	S	PESO WEIGHT
		GAS	mm	mm	mm	mm	mm	mm	mm	mm	Kg
V0272	VBPSE 1/4" A	G 1/4"	80	96	33,5	50	15	40	60	30	1,028
V0274	VBPSE 3/8" A	G 3/8"	80	96	33,5	50	15	40	60	30	0,996
V0276	VBPSE 1/2" A	G 1/2"	105	121	49	70	17,5	40	80	35	2,000





2.6 - VALVOLE DI BLOCCO PILOTATE A SEMPLICE EFFETTO FLANGIABILI

2.6 - SINGLE PILOT OPERATED CHECK VALVES FLANGEABLE

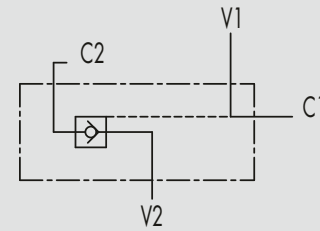
TIPO/TYPE
VBPSE FLSCHEMA IDRAULICO
HYDRAULIC DIAGRAM**IMPIEGO:**

Valvola utilizzata per bloccare in posizione un cilindro in un solo senso, consentendo il flusso in una direzione ed impedendolo in senso contrario fino a quando non viene applicata la pressione di pilotaggio. Adatta per essere fissata direttamente sull'attuatore tramite flangiatura.

MATERIALI E CARATTERISTICHE:**Corpo:** acciaio zincato**Componenti interni:** acciaio temprato termicamente e rettificato**Guarnizioni:** BUNA N standard**Tenuta:** a cono guidato. Non ammette trafilamenti**MONTAGGIO:**

Collegare V1 e V2 all'alimentazione, C1 all'attuatore al lato di flusso libero e flangiare C2 al lato dell'attuatore dove si desidera la tenuta.

A RICHIESTA:

- senza guarnizione OR sul pilota

USE AND OPERATION:

These valves are used to block the cylinder in one direction. Flow is free in one direction and blocked in the reverse direction until pilot pressure is applied. This valve can be fixed directly on cylinder.

MATERIALS AND FEATURES:**Body:** zinc-plated steel.**Internal parts:** hardened and ground steel**Seals:** BUNA N standard**Poppet type:** any leakage.**APPLICATIONS:**

Connect V1 and V2 to the pressure flow, C1 to the free flow side of the actuator and C2 to the actuator's side you want the flow to be blocked.

ON REQUEST:

- without seal on the pilot piston

PERDITE DI CARICO PRESSURE DROPS CURVE

Temperatura olio: 50°C - Viscosità olio: 30 cSt
Oil temperature: 50°C - Oil viscosity: 30 cSt

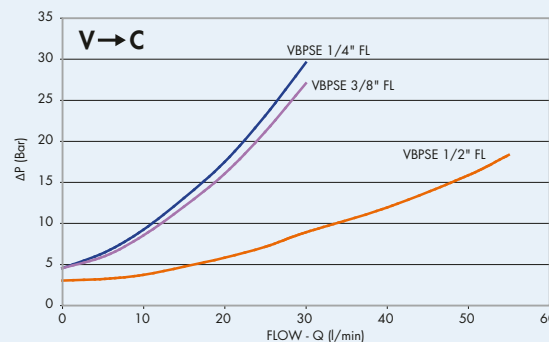
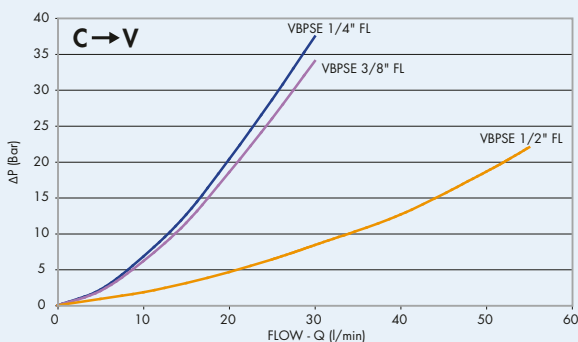



CODICE CODE	SIGLA TYPE	RAPP.PILOT. PILOT RATIO	PORTATA MAX MAX FLOW Lt./min	PRESSIONE MAX MAX PRESSURE Bar	PRESSIONE APERTURA CRACKING PRESSURE Bar
V0268	VBPSE 1/4" FL	1 : 5,5	20	350	4,5
V0269	VBPSE 3/8" FL	1 : 5,5	30	350	4,5
V0270	VBPSE 1/2" FL	1 : 4,5	55	350	3

DXF

2

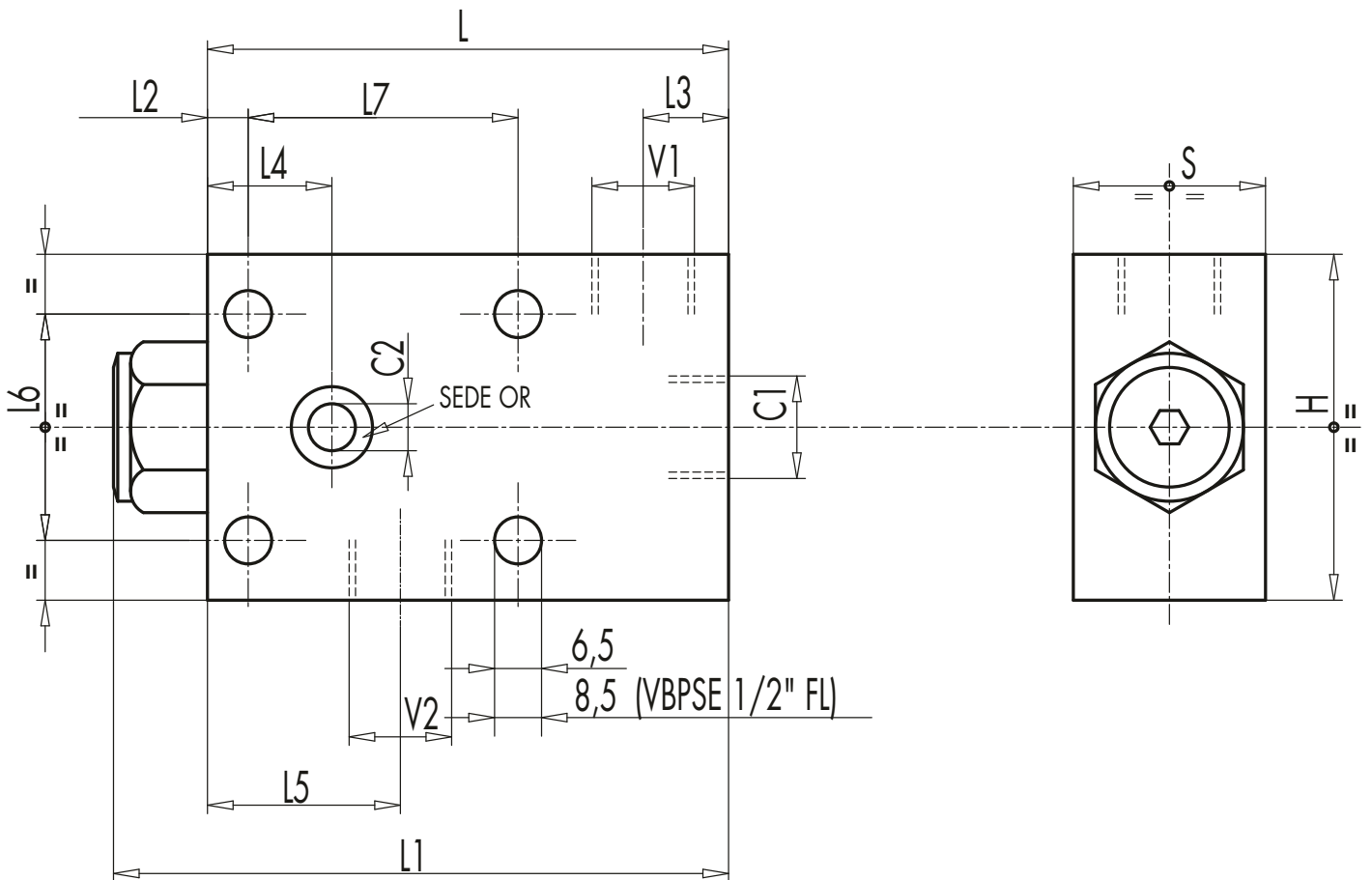

CODICE CODE	SIGLA TYPE	V1-V2 C1	C2	L	L1	L2	L3	L4	L5	L6	L7	H	S	O-ring	PESO WEIGHT
		GAS	mm	mm	mm	mm	mm	mm	mm	mm	mm	mm	mm	mm	mm
V0268	VBPSE 1/4" FL	G 1/4"	Ø5	70	74	6,5	13	15,5	27	35	35	50	30	1,78x12,42	0,692
V0269	VBPSE 3/8" FL	G 3/8"	Ø6,5	75	88	10	14	14	46	40	35	60	30	1,78x12,42	0,924
V0270	VBPSE 1/2" FL	G 1/2"	Ø9	100	116	10,5	18	18	32	40	40	80	35	2,62x15,54	1,900





2.7 - VALVOLE DI BLOCCO PILOTATE A SEMPLICE EFFETTO CON RUBINETTO

2.7 - SINGLE PILOT OPERATED CHECK VALVES WITH MANUAL SHUT-OFF

TIPO/TYPE
VBPSE c/RUB.



SCHEMA IDRAULICO
HYDRAULIC DIAGRAM

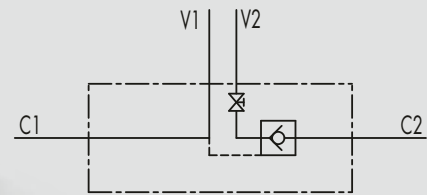

IMPIEGO:

Valvola utilizzata per bloccare in posizione un cilindro in un solo senso, consentendo il flusso in una direzione ed impedendolo in senso contrario fino a quando non viene applicata la pressione di pilotaggio. Per l'alta sicurezza offerta sono particolarmente indicate per il montaggio su cilindri stabilizzatori: la chiusura del rubinetto, dopo aver appoggiato gli stabilizzatori, consente infatti di escludere i rischi derivanti da eventuali errori di manovra.

MATERIALI E CARATTERISTICHE:

Corpo: acciaio zincato

Componenti interni: acciaio temprato termicamente e rettificato

Guarnizioni: BUNA N standard

Tenuta: a cono guidato. Non ammette trafilamenti

Reversibilità della leva.

MONTAGGIO:

Collegare V1 e V2 all'alimentazione, C1 al lato dell'attuatore con flusso libero e C2 al lato dell'attuatore dove si desidera la tenuta.

A RICHIESTA:

- senza guarnizione OR sul pilota
- leva destra o sinistra (da specificare in fase d'ordine).

USE AND OPERATION

Pilot check valves are used to block the actuator in both directions. Flow is free in one direction and blocked in the reverse direction until pilot pressure is applied. These valves are very safe, that's why they are ideal to be assembled on crane hydraulic cylinders. The shut-off system enables to exclude any risk caused by possible manoeuvring errors.

MATERIALS AND FEATURES

Body: zinc-plated steel

Internal parts: hardened and ground steel

Seals: BUNA N standard

Poppet type: any leakage.

Reversible lever.

APPLICATIONS

Connect V1 and V2 to the pressure flow, C1 to the free flow side of the actuator and C2 to the actuator's side you want the flow to be blocked.

ON REQUEST

- without seal on pilot piston
- right or left side lever (to specify in the order).

PERDITE DI CARICO PRESSURE DROPS CURVE

Temperatura olio: 50°C - Viscosità olio: 30 cSt
Oil temperature: 50°C - Oil viscosity: 30 cSt

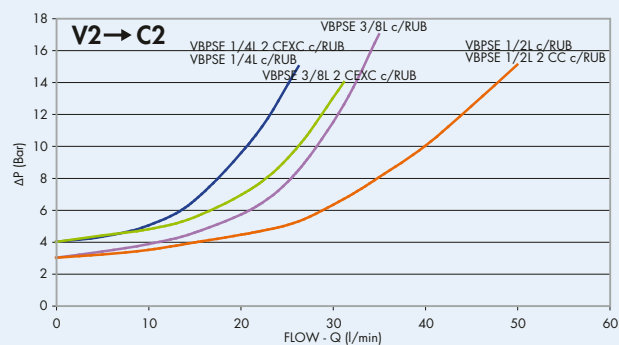
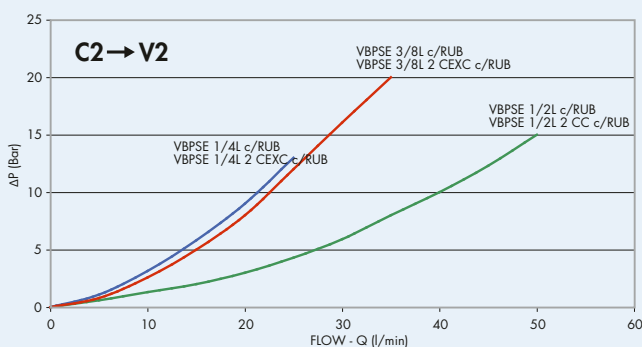



CODICE CODE	SIGLA TYPE	RAPP.PILOT. PILOT RATIO	PORTATA MAX MAX FLOW Lt./min	PRESSIONE MAX MAX PRESSURE Bar	PRESSIONE APERTURA CRACKING PRESSURE Bar
V0072/SE	VBPSE 1/4" L c/RUBINETTO	1 : 5,5	20	350	4
V0074/SE	VBPSE 3/8" L c/RUBINETTO	1 : 5,5	30	350	3
V0076/SE	VBPSE 1/2" L c/RUBINETTO	1 : 5	50	350	3
V0132/SE*	VBPSE 1/4" L c/RUB. 2 CEXC	1 : 5,5	20	350	4
V0134/SE*	VBPSE 3/8" L c/RUB. 2 CEXC	1 : 5,5	30	350	4
V0136/SE*	VBPSE 1/2" L c/RUB. 2 CC	1 : 5	50	350	3

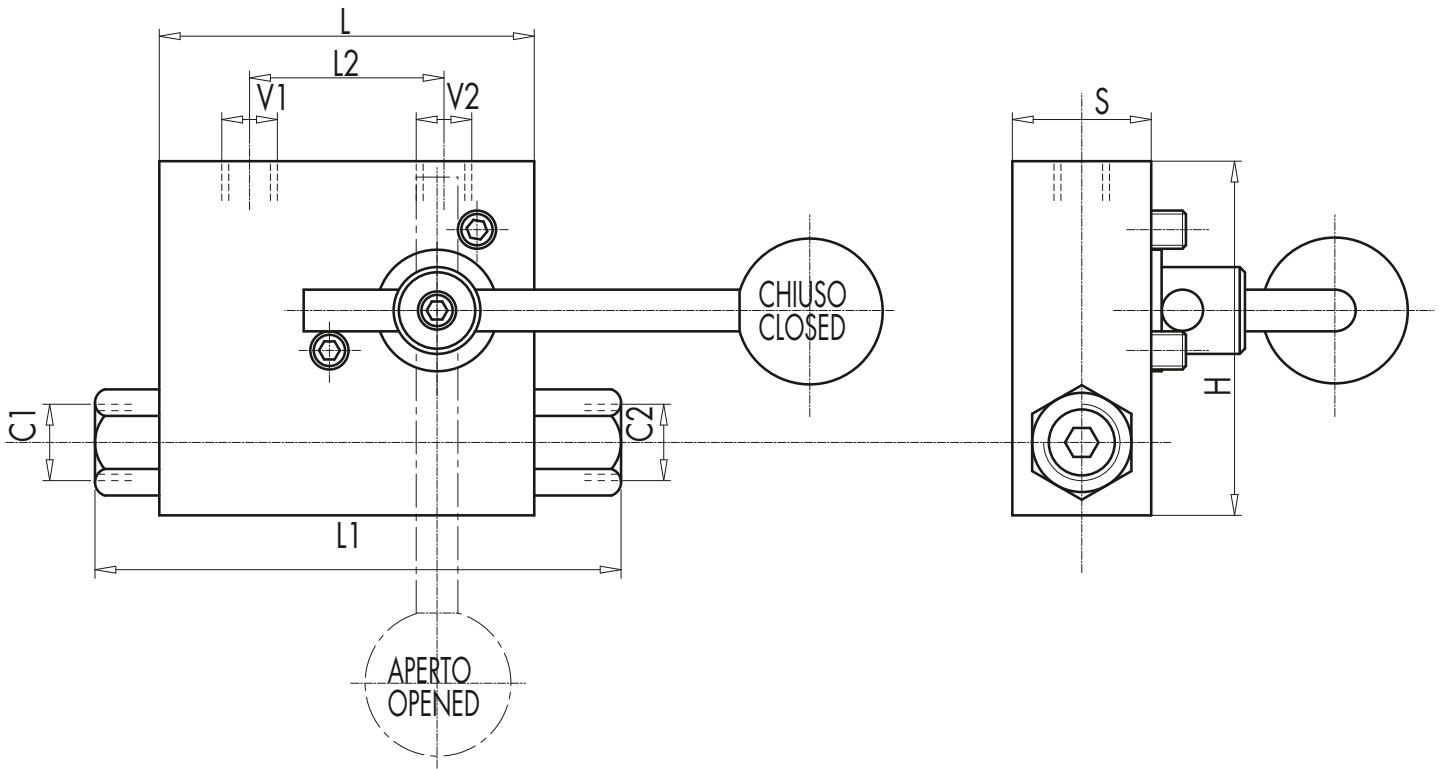

CODICE CODE	SIGLA TYPE	V1-V2 C1-C2	L	L1	L2	H	S	PESO WEIGHT
		GAS	mm	mm	mm	mm	mm	Kg
V0072/SE	VBPSE 1/4" L c/RUBINETTO	G 1/4"	64	112	34	60	30	0,994
V0074/SE	VBPSE 3/8" L c/RUBINETTO	G 3/8"	64	118	36	60	30	0,964
V0076/SE	VBPSE 1/2" L c/RUBINETTO	G 1/2"	90	142	45	70	35	1,708
V0132/SE*	VBPSE 1/4" L c/RUB. 2 CEXC	G 1/4" 12L	64	131	34	60	30	1,006
V0134/SE*	VBPSE 3/8" L c/RUB. 2 CEXC	G 3/8" 12L	64	131	36	60	30	0,982
V0136/SE*	VBPSE 1/2" L c/RUB. 2 CC	G 1/2" 15L	90	164	45	70	35	1,752

*DIN 2353 *pipe DIN 2353





2.8 - VALVOLE DI BLOCCO PILOTATE A SEMPLICE EFFETTO CON PILOTAGGIO SEPARATO

2.8 - EXTERNAL SINGLE PILOT OPERATED CHECK VALVES

TIPO/TYPE
VBPSE PS

SCHEMA IDRAULICO
HYDRAULIC DIAGRAM

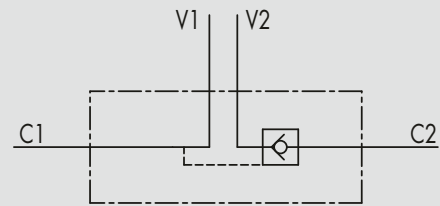

IMPIEGO:

Valvola utilizzata per bloccare in posizione un cilindro in un solo senso, consentendo il flusso in una direzione ed impedendolo in senso contrario fino a quando non viene applicata la pressione di pilotaggio. Il pilotaggio separato la rende insensibile alle contropressioni a monte (linea V). Se ne consiglia il montaggio su 2 o più cilindri in parallelo con una valvola regolatrice di flusso garantendo così una discesa del carico bilanciata e molto dolce.

MATERIALI E CARATTERISTICHE:

Corpo: alluminio

Componenti interni: acciaio temprato termicamente e rettificato

Guarnizioni: BUNA N standard

Tenuta: a cono guidato. Non ammette trafilamenti

MONTAGGIO:

Collegare V1 e V2 all'alimentazione e C1 e C2 all'attuatore come indicato sullo schema.

USE AND OPERATION:

These valves are used to block the cylinder in one direction. The flow is free in one direction and blocked in the reverse one until pilot pressure is applied. Separated mounting enables valves to be insensitive to back pressure on the line V. Assembly on 2 or more parallel cylinders with a flow regulator valve to allow balanced and soft descent is highly recommended.

MATERIALS AND FEATURES:

Body: aluminium

Internal parts: hardened and ground steel

Seals: BUNA N standard

Poppet type: any leakage.

APPLICATIONS:

Connect V1 and V2 to the pressure flow and C1 and C2 to the actuator as indicated in the diagram.

PERDITE DI CARICO PRESSURE DROPS CURVE

Temperatura olio: 50°C - Viscosità olio: 30 cSt
Oil temperature: 50°C - Oil viscosity: 30 cSt

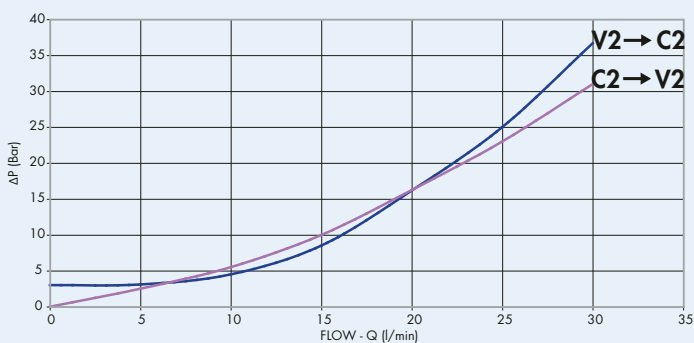



CODICE CODE	SIGLA TYPE	RAPP.PILOT. PILOT RATIO	PORTATA MAX MAX FLOW Lt./min	PRESSIONE MAX MAX PRESSURE Bar	PRESSIONE APERTURA CRACKING PRESSURE Bar
V0231	VBPSE 3/8" PS	1 : 12	35	350	3

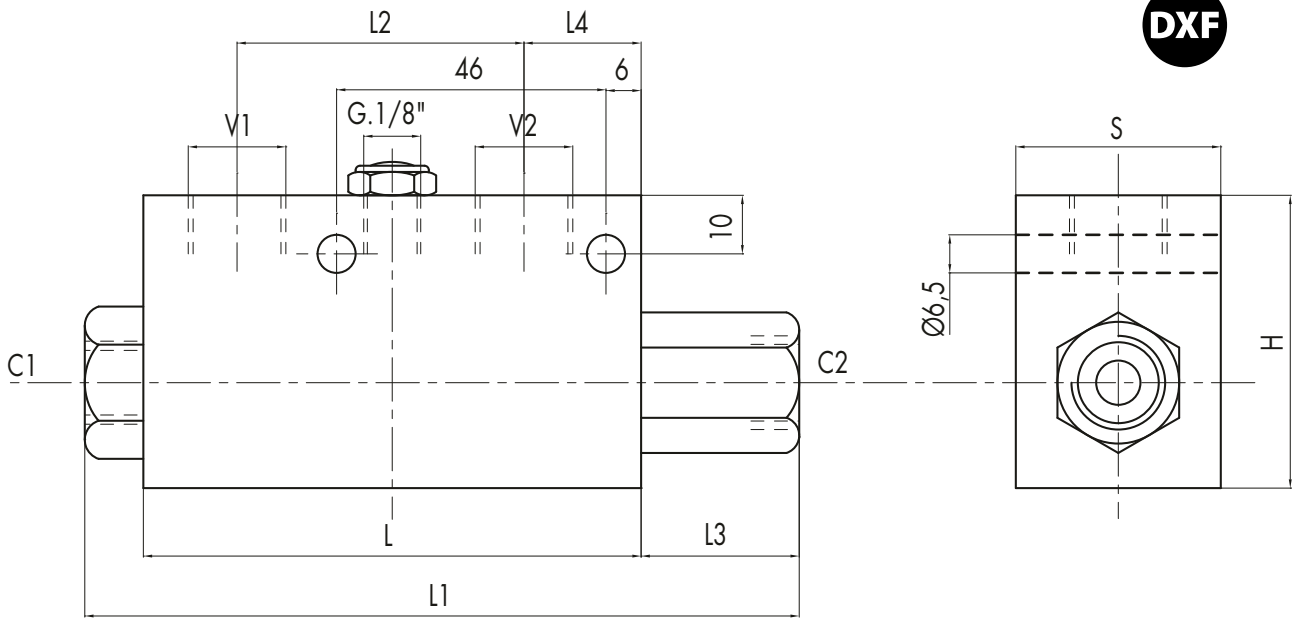

DXF

2

DXF

SCHEMA DI MONTAGGIO
MOUNTING DIAGRAM

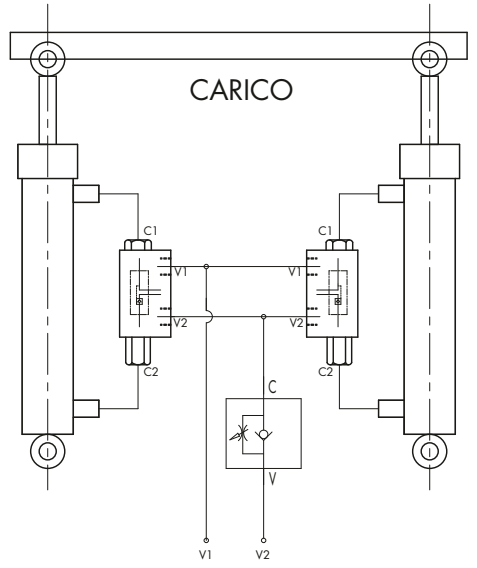

CODICE CODE	SIGLA TYPE	C1-C2 V1-V2	L	L1	L2	L3	L4	H	S	PESO WEIGHT
		GAS	mm	mm	mm	mm	mm	mm	mm	Kg
V0231	VBPSE 3/8" PS	G 3/8"	85	122	49	27	20	50	35	0,690

