



VALVOLE ANTIURTO
DUAL CROSS RELIEF VALVES

5





5.1 - VALVOLE ANTIURTO

5.1 - DUAL CROSS RELIEF VALVES

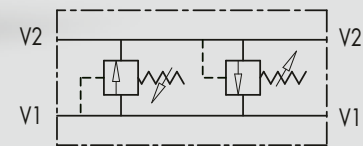
TIPO/TYPE
VAUSCHEMA IDRAULICO
HYDRAULIC DIAGRAM**IMPIEGO:**

Costituite da due valvole di massima pressione con scarico incrociato, sono utilizzate per limitare la pressione in entrambi i rami di un attuatore o motore idraulico ad un determinato valore di taratura. Trovano il miglior impiego sia come valvole antishock sia per regolare i due rami di un circuito idraulico a diversi valori di pressione.

MATERIALI E CARATTERISTICHE:

Corpo: acciaio zincato
Componenti interni: acciaio temprato termicamente e rettificato
Guarnizioni: BUNA N standard
Tenuta: a cono guidato. Trafilamento trascurabile

MONTAGGIO:

Collegare V1 e V2 o all'alimentazione o all'attuatore/motore idraulico. Viceversa per le due bocche V1 e V2 rimanenti. Se ne raccomanda il montaggio vicino all'attuatore per limitare le perdite di carico e ottenere un pronto funzionamento.

A RICHIESTA:

- Molle per diversi campi di taratura (vedi tabella)
- Pressione di taratura diversa da quella standard (CODICE/T specificando il valore di taratura)

USE AND OPERATION:

Made up by 2 relief valves with crossed tank, this valve is used to block pressure to a certain setting in the 2 ports of an actuator/hydraulic motor. It's ideal to provide protection against sudden shock pressures and to adjust different pressures in the 2 ports of an hydraulic circuit as well.

MATERIALS AND FEATURES:

Body: zinc-plated steel
Internal parts: hardened and ground steel
Seals: BUNA N standard
Poppet type: minor leakage

APPLICATIONS:

Connect V1 and V2 to the pressure flow or to the actuator/hydraulic motor. Vice versa for the remaining ports V1 and V2. Mounting by the actuator is highly recommended in order to avoid pressure drops.

UPON REQUEST

- different setting range (see the table)
- other setting available (CODE/T: please specify the desired setting)

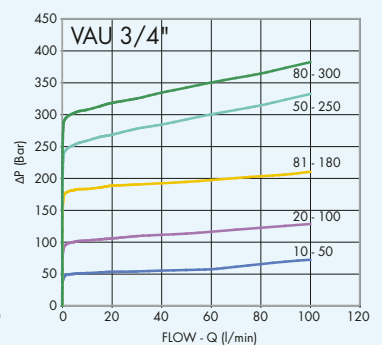
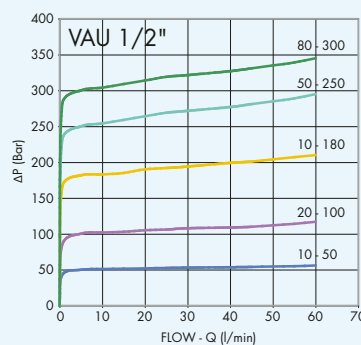
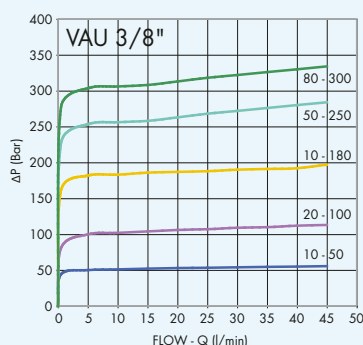
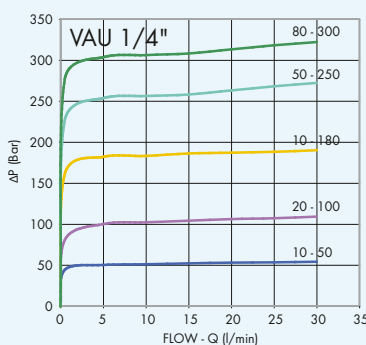
PRESSIONE/PORTATA
PRESSURE/FLOWTemperatura olio: 50°C - Viscosità olio: 30 cSt
Oil temperature: 50°C - Oil viscosity: 30 cSt



CODICE
CODE

SIGLA
TYPE

PORTATA MAX
MAX FLOW
Lt./min

V0438	VAU 1/4"	30
V0440	VAU 3/8"	45
V0450	VAU 1/2"	70
V0460	VAU 3/4"	110

DXF

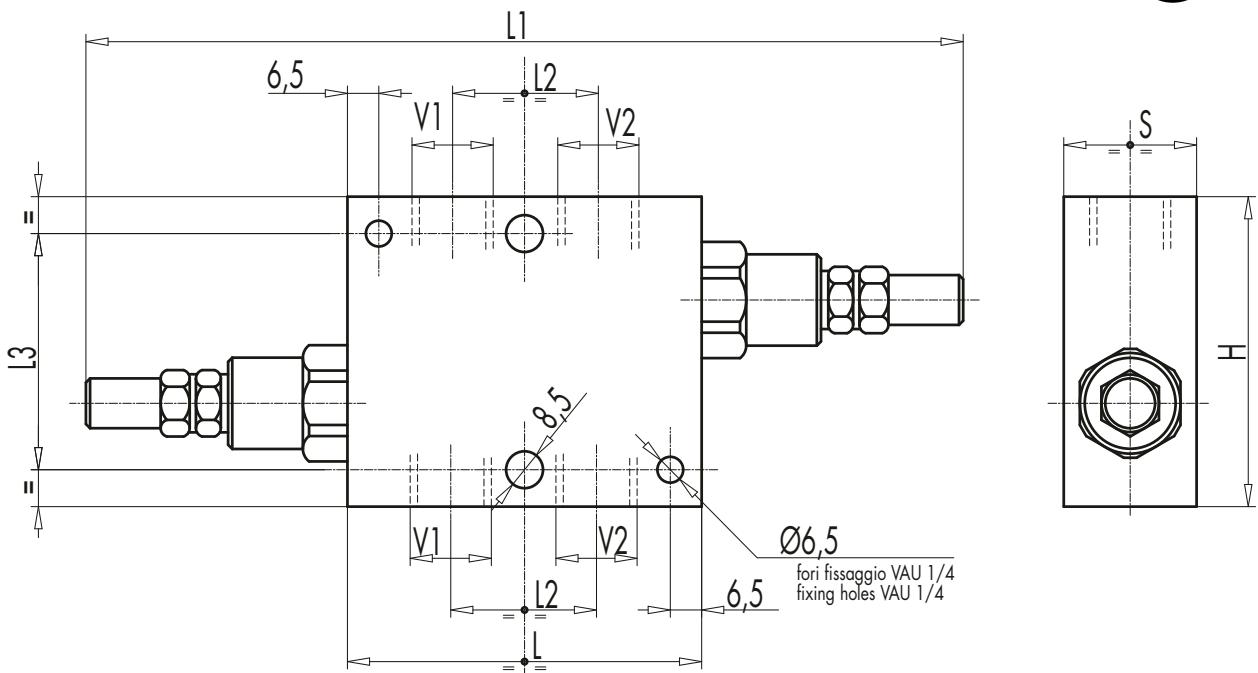

5

CODICE CODE	SIGLA TYPE	V1-V2	L	L1	L2	L3	H	S	PESO WEIGHT
		GAS	mm	mm	mm	mm	mm	mm	Kg
V0438	VAU 1/4"	G 1/4"	60	184	26	54	70	30	0,988
V0440	VAU 3/8"	G 3/8"	80	204	33	54	70	30	1,208
V0450	VAU 1/2"	G 1/2"	80	204	38	54	70	30	1,150
V0460	VAU 3/4"	G 3/4"	95	219	44	54	80	35	1,680

MOLLE • SPRINGS

Campo di taratura Setting range (bar)	Incremento bar per giro Pressure increase (bar/turn) Q = 4 l/min	Taratura standard Standard setting (bar)
10 - 50*	7	30
20 - 100	12	75
10 - 180 STANDARD	30	90
50 - 250	45	130
80 - 300	50	150

*Per tarature inferiori a 70 Bar: Q = 12 l/min *For setting less than 70 Bar: Q = 12 l/min

REGOLAZIONE - ADJUSTEMENT

CODICE/V • CODE/V	Volantino Handknob
CODICE/PP • CODE/PP	Predisposizione alla piombatura Arranged for sealing cap
CODICE/P • CODE/P	Piombatura Sealing cap





5.2 - VALVOLA ANTIURTO DIFFERENZIATA 1"

5.2 - DIFFERENTIAL DUAL CROSS RELIEF VALVES, 1"

TIPO/TYPE
VAU 1"



SCHEMA IDRAULICO
HYDRAULIC DIAGRAM

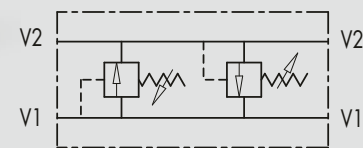

IMPIEGO:

Costituita da due valvole di massima pressione con scarico incrociato, viene utilizzata per limitare la pressione in entrambi i rami di un attuatore o motore idraulico ad un determinato valore di taratura. Trova il miglior impiego sia come valvole antishock sia per regolare i due rami di un circuito idraulico a diversi valori di pressione. L'apertura differenziata rende questa valvola più lenta all'apertura ma più costante alla taratura al variare della portata.

MATERIALI E CARATTERISTICHE:

Corpo: acciaio zincato

Componenti interni: acciaio temprato termicamente e rettificato

Guarnizioni: BUNA N standard

Tenuta: a cono guidato. Trafilamento trascurabile

MONTAGGIO:

Collegare V1 e V2 o all'alimentazione o all'attuatore/motore idraulico. Viceversa per le due bocche V1 e V2 rimanenti. Se ne raccomanda il montaggio vicino all'attuatore per limitare le perdite di carico e ottenere un pronto funzionamento.

A RICHIESTA:

- Molle per diversi campi di taratura (vedi tabella)
- Pressione di taratura diversa da quella standard (CODICE/T specificando il valore di taratura)

PRESSIONE/PORTATA
PRESSURE/FLOW

Temperatura olio: 50°C - Viscosità olio: 30 cSt
Oil temperature: 50°C - Oil viscosity: 30 cSt

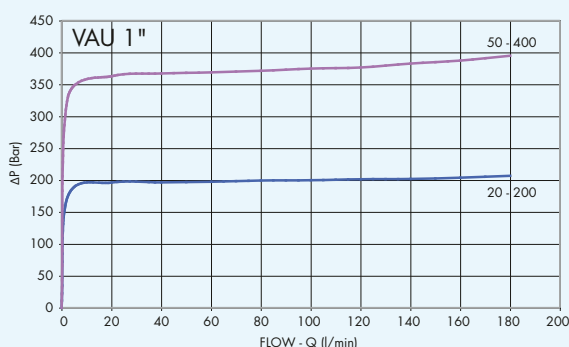

USE AND OPERATION:

Made up by 2 relief valves with crossed tank, this valve is used to block pressure to a certain setting in the 2 ports of an actuator/hydraulic motor. It's ideal to provide protection against sudden shock pressures and to adjust different pressures in the 2 ports of an hydraulic circuit as well. The differential valve makes the opening slower but more constant setting even with flow changes.

MATERIALS AND FEATURES:

Body: zinc-plated steel

Internal parts: hardened and ground steel

Seals: BUNA N standard

Poppet type: minor leakage

APPLICATIONS:

Connect V1 and V2 to the pressure flow or to the actuator/hydraulic motor. Vice versa for the remaining ports V1 and V2. Mounting by the actuator is highly recommended in order to avoid pressure drops.

UPON REQUEST

- different setting range (see the table)
- other setting available (CODE/T: please specify the desired setting)





CODICE
CODE

SIGLA
TYPE

PORTATA MAX
MAX FLOW
Lt./min

V0470

VAU 1"

160

DXF

5

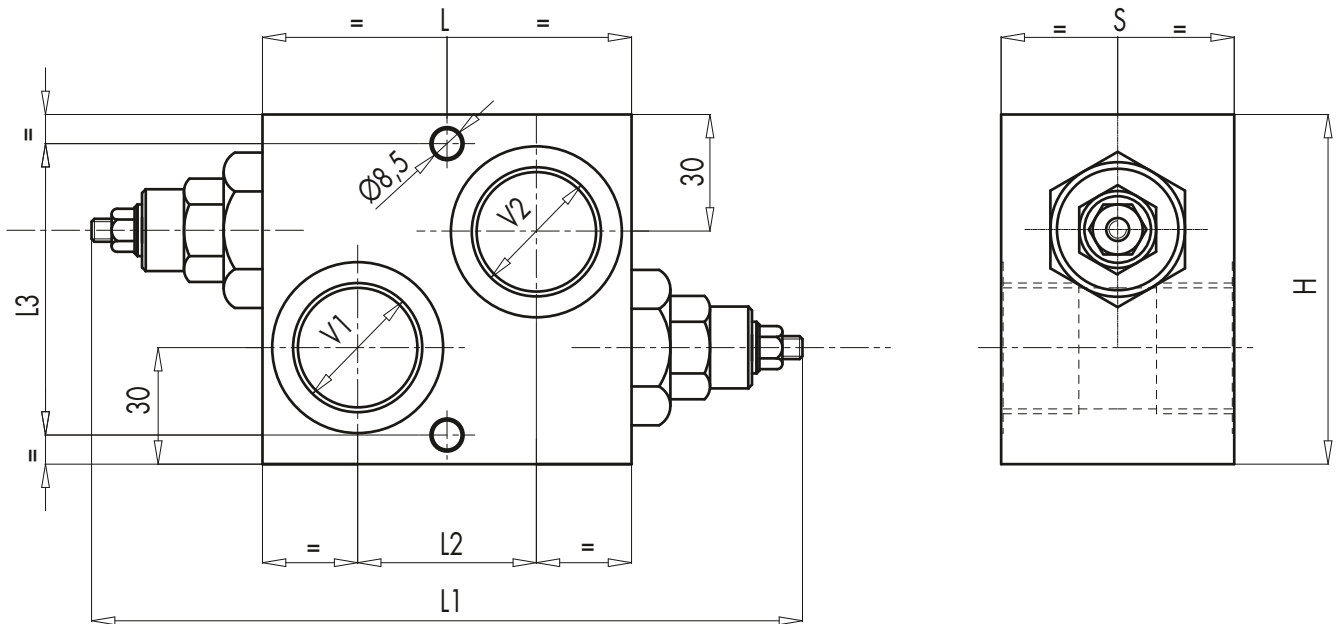

CODICE CODE	SIGLA TYPE	V1 - V2	L	L1	L2	L3	H	S	PESO WEIGHT
		GAS	mm	mm	mm	mm	mm	mm	mm
V0470	VAU 1"	G 1"	95	177	46	75	90	60	3,200

MOLLE • SPRINGS

Campo di taratura Setting range (bar)	Incremento bar per giro Pressure increase (bar/turn) Q = 4 l/min	Taratura standard Standard setting (bar)
20 - 200	40	160
50 - 400 STANDARD	80	180

REGOLAZIONE - ADJUSTEMENT

CODICE/V • CODE/V	Volantino Handknob
CODICE/PP • CODE/PP	Predisposizione alla piombatura Arranged for sealing cap
CODICE/P • CODE/P	Piombatura Sealing cap





5.3 - VALVOLE DI MASSIMA PRESSIONE DOPPIE INCROCIATE

5.3 - DUAL CROSS RELIEF VALVES

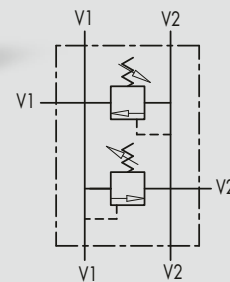
TIPO/TYPE
VMPDISCHEMA IDRAULICO
HYDRAULIC DIAGRAM**IMPIEGO:**

Costituite da due valvole di massima pressione con scarico incrociato, sono utilizzate per limitare la pressione in entrambi i rami di un attuatore o motore idraulico ad un determinato valore di taratura. Trovano il miglior impiego sia come valvole antishock sia per regolare i due rami di un circuito idraulico a diversi valore di pressione. La presenza di sei attacchi (2 entrate - 4 uscite reversibili) permette l'utilizzo di una sola valvola con due cilindri.

MATERIALI E CARATTERISTICHE:

Corpo: acciaio zincato
Componenti interni: acciaio temprato termicamente e rettificato
Guarnizioni: BUNA N standard
Tenuta: a cono guidato. Trafilamento trascurabile

MONTAGGIO:

Collegare V1 e V2 o all'alimentazione o all'attuatore/motore idraulico. Viceversa per le due bocche V1 e V2 rimanenti. Se ne raccomanda il montaggio vicino all'attuatore per limitare le perdite di carico e ottenere un pronto funzionamento.

A RICHIESTA:

- Molle per diversi campi di taratura (vedi tabella)
- Pressione di taratura diversa da quella standard (CODICE/T specificando il valore di taratura)

PRESSIONE/PORTATA
PRESSURE/FLOW

USE AND OPERATION:

Made up by 2 relief valves with crossed tank, this valve is used to block pressure to a certain setting in the 2 ports of an actuator/ hydraulic motor. It's ideal to provide protection against sudden shock pressures and to adjust different pressures in the 2 ports of an hydraulic circuit as well. The 6 ports (2 ways in and 4 ways out reversible) enable to use just 1 valves for 2 cylinders.

MATERIALS AND FEATURES:

Body: zinc-plated steel.
Internal parts: hardened and ground steel.
Seals: BUNA N standard
Poppet type: minor leakage

APPLICATIONS:

Connect V1 and V2 to the pressure flow or to the actuator/ hydraulic motor. Vice versa for the remaining ports V1 and V2. Mounting by the actuator is highly recommended in order to avoid pressure drops.

ON REQUEST:

- different setting range (see the table)
- other setting available (CODE/T: please specify the desired setting)

Temperatura olio: 50°C - Viscosità olio: 30 cSt
Oil temperature: 50°C - Oil viscosity: 30 cSt

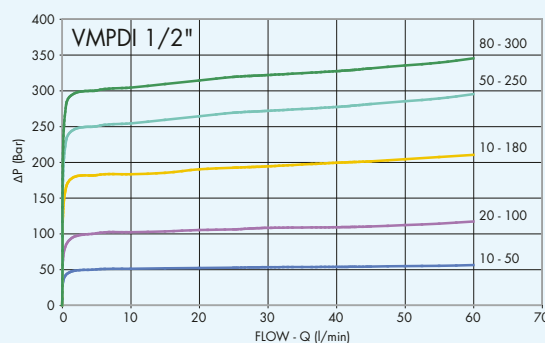
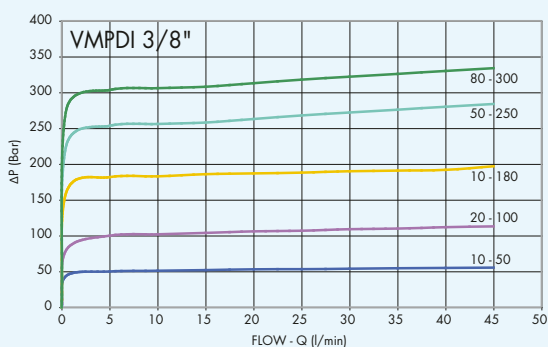



CODICE
CODE

SIGLA
TYPE

PORTATA MAX
MAX FLOW
Lt./min

V0737

VMPDI 3/8"

45

V0738

VMPDI 1/2"

70

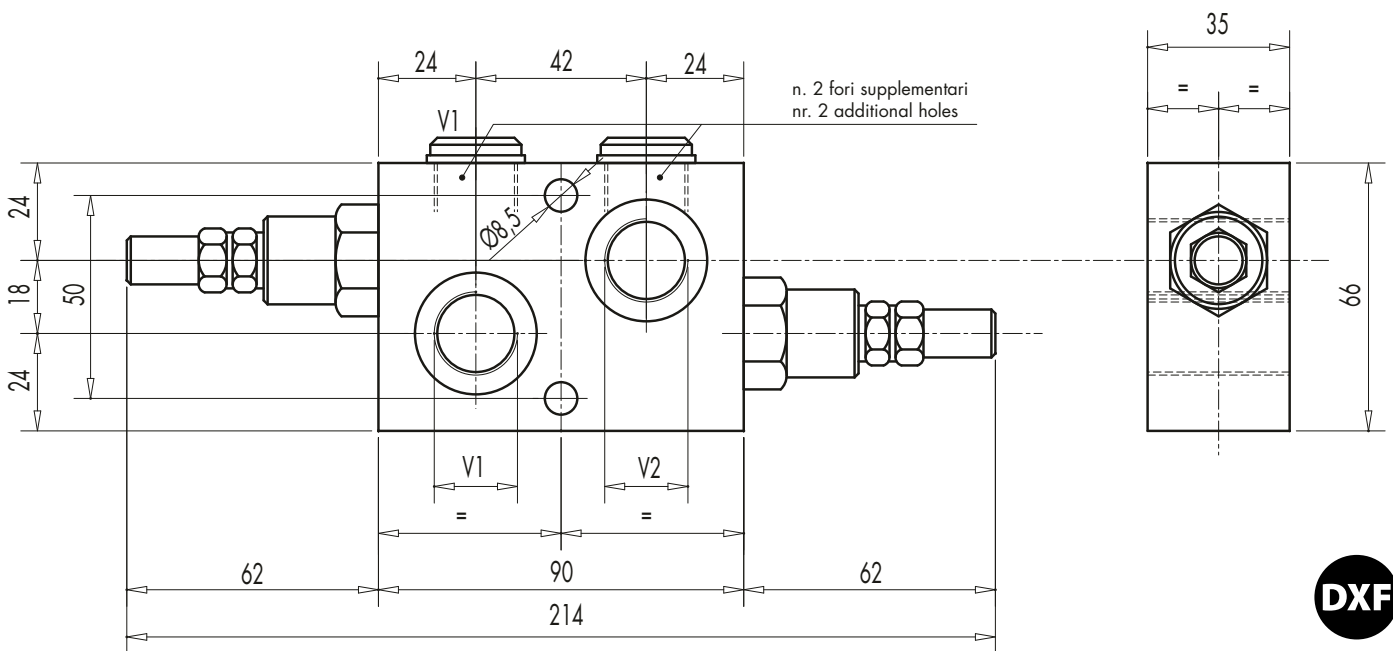

5

CODICE
CODE

SIGLA
TYPE

V1 - V2

PESO
WEIGHT

V0737

VMPDI 3/8"

GAS

Kg

G 3/8"

1,520

V0738

VMPDI 1/2"

G 1/2"

1,490

MOLLE • SPRINGS

Campo di taratura Setting range (bar)	Incremento bar per giro Pressure increase (bar/turn) Q = 4 l/min	Taratura standard Standard setting (bar)
10 - 50*	7	30
20 - 100	12	75
10 - 180 STANDARD	30	90
50 - 250	45	130
80 - 300	50	150

*Per tarature inferiori a 70 Bar: Q = 12 l/min *For setting less than 70 Bar: Q = 12 l/min

REGOLAZIONE - ADJUSTEMENT

CODICE/V • CODE/V	Volantino Handknob
CODICE/PP • CODE/PP	Predisposizione alla piombatura Arranged for sealing cap
CODICE/P • CODE/P	Piombatura Sealing cap





5.4 - VALVOLE ANTIURTO FLANGIABILI SU MOTORI DANFOSS SERIE OMS - OMP/OMR - OMT

5.4 - DUAL CROSS RELIEF VALVE FLANGEABLE ON DANFOSS MOTORS OMS - OMP/OMR - OMT



SCHEMA IDRAULICO (con sbloccafreno)
HYDRAULIC DIAGRAM (with brake unclaping)

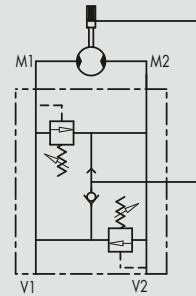

IMPIEGO:

Costituite da due valvole di massima pressione con scarico incrociato, sono utilizzate per limitare la pressione in entrambi i rami di un attuatore o motore idraulico ad un determinato valore di taratura. Trovano il miglior impiego sia come valvole antishock sia per regolare i due rami di un circuito idraulico a diversi valore di pressione. La flangiatura diretta, adatta per motori Danfoss della serie OMS, OMP-OMR e OMT, garantisce la massima sicurezza, minime perdite di carico e compattezza d'installazione.

MATERIALI E CARATTERISTICHE:

- Corpo:** acciaio zincato
- Componenti interni:** acciaio temprato termicamente e rettificato
- Guarnizioni:** BUNA N standard
- Tenuta:** a cono guidato. Trafilamento trascurabile

MONTAGGIO:

Flangiare M1 e M2 al motore e collegare le bocche V1 e V2 all'alimentazione.

A RICHIESTA:

- Molle per diversi campi di taratura (vedi tabella)
- Pressione di taratura diversa da quella standard (CODICE/T specificando il valore di taratura)
- Versione semplice effetto, con una sola valvola di massima (CODICE/SE)
- Valvola con sbloccafreno (CODICE/SF)

USE AND OPERATION

Made up by 2 relief valves with crossed tank, this valve is used to block pressure to a certain setting in the 2 ports of an actuator/hydraulic motor. It's ideal to provide protection against sudden shock pressures and to adjust different pressures in the 2 ports of an hydraulic circuit as well. Direct flange is ideal for Danfoss motors type OMS, OMP-OMR and OMT and provides a maximum safety, very low pressure drops and solid installation.

MATERIALS AND FEATURES:

- Body:** zinc-plated steel
- Internal parts:** hardened and ground steel.
- Seals:** BUNA N standard
- Poppet type:** minor leakage

APPLICATIONS:

Flange M1 and M2 directly to the motor and connect ports V1 and V2 to pressure flow.

ON REQUEST:

- different setting range (see the table)
- other setting available (CODE/T: please specify the desired setting)
- single acting with just 1 relief valve available (CODE/ SE)
- brake unclaping (CODE/ SF)

PRESSIONE/PORTATA
PRESSURE/FLOW

Temperatura olio: 50°C - Viscosità olio: 30 cSt
Oil temperature: 50°C - Oil viscosity: 30 cSt

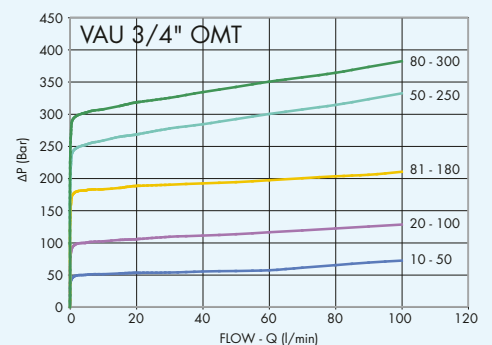
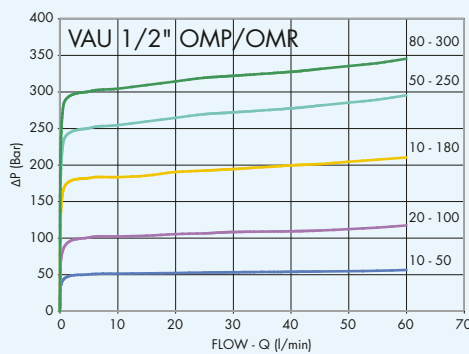
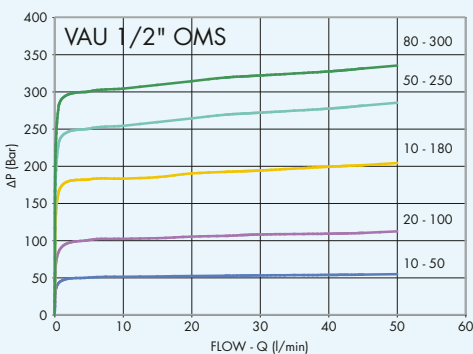



CODICE
CODE

SIGLA
TYPE

PORTATA MAX
MAX FLOW
Lt./min

V0490

VAU 1/2" OMS

50

V0500

VAU 1/2" OMP/OMR

60

V0505

VAU 3/4" OMT

100

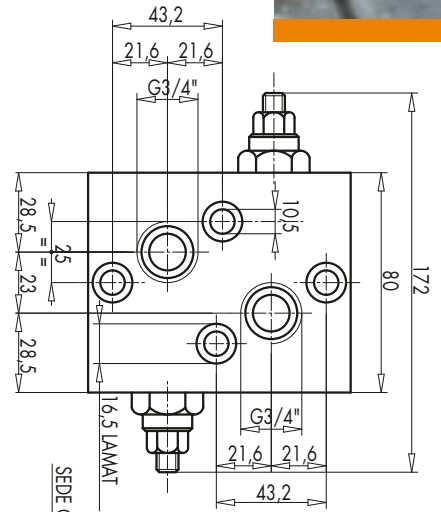
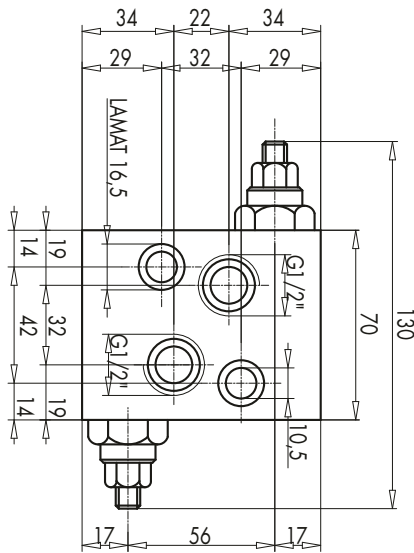
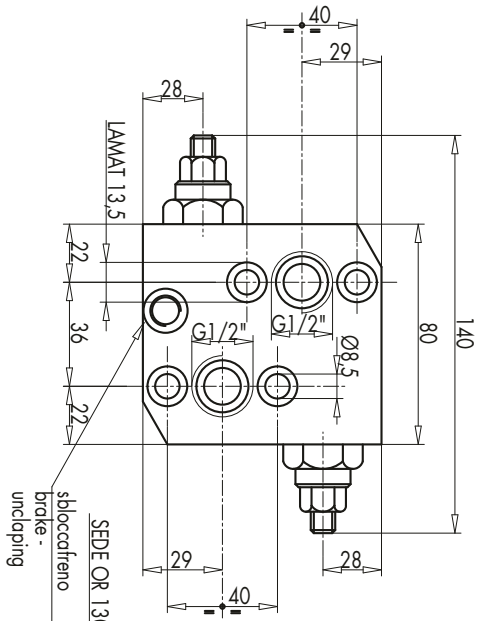

5

VAU OMP/OMR **DXF**

VAU OMR **DXF**

VAU OMT **DXF**

CODICE
CODE

SIGLA
TYPE

V1 - V2

PESO
WEIGHT

V0490

VAU 1/2" OMS

GAS

Kg

V0500

VAU 1/2" OMP/OMR

G 1/2"

1,326

V0505

VAU 3/4" OMT

G 1/2"

1,752

G 3/4"

1,920

MOLLE • SPRINGS

Campo di taratura Setting range (bar)	Incremento bar per giro Pressure increase (bar/turn) Q = 4 l/min	Taratura standard Standard setting (bar)
10 - 50*	7	30
20 - 100	12	75
10 - 180 STANDARD	30	90
50 - 250	45	130
80 - 300	50	150

*Per tarature inferiori a 70 Bar: Q = 12 l/min *For setting less than 70 Bar: Q = 12 l/min

REGOLAZIONE - ADJUSTEMENT

CODICE/V • CODE/V	Volantino Handknob
CODICE/PP • CODE/PP	Predisposizione alla piombatura Arranged for sealing cap
CODICE/P • CODE/P	Piombatura Sealing cap





5.5 - VALVOLA ANTIURTO FLANGIABILE SU MOTORI SAMHYDRAULIK SERIE AG - AR

TIPO/TYPE
VAU AG-AR

5.5 - DUAL CROSS RELIEF VALVE FLANGEABLE ON SAMHYDRAULIK MOTORS AG - AR



SCHEMA IDRAULICO
(con sbloccafreno)
HYDRAULIC DIAGRAM
(with brake unclaping)

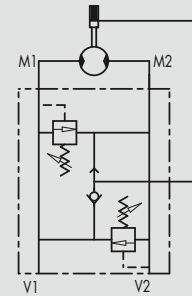

IMPIEGO:

Costituite da due valvole di massima pressione con scarico incrociato, sono utilizzate per limitare la pressione in entrambi i rami di un attuatore o motore idraulico ad un determinato valore di taratura. Trovano il miglior impiego sia come valvole antishock sia per regolare i due rami di un circuito idraulico a diversi valore di pressione. La flangiatura diretta, adatta per motori Samhydraulik della serie AG-AR, garantisce la massima sicurezza, minime perdite di carico e compattezza d'installazione.

MATERIALI E CARATTERISTICHE:

Corpo: acciaio zincato

Componenti interni: acciaio temprato termicamente e rettificato

Guarnizioni: BUNA N standard

Tenuta: a cono guidato. Trafilamento trascurabile

MONTAGGIO:

Flangiare M1 e M2 direttamente al motore tramite i bulloni forati in dotazione e collegare V1 e V2 all'alimentazione.

A RICHIESTA:

- Molle per diversi campi di taratura (vedi tabella)
- Pressione di taratura diversa da quella standard (CODICE/T specificando il valore di taratura)
- Valvola con sbloccafreno (CODICE/SF)

USE AND OPERATION

Made up by 2 relief valves with crossed tank, this valve is used to block pressure to a certain setting in the 2 ports of an actuator/hydraulic motor. It's ideal to provide protection against sudden shock pressures and to adjust different pressures in the 2 ports of an hydraulic circuit as well. Direct flange is ideal for Samhydraulik motors type AG-AR and provides a maximum safety, very low pressure drops and solid installation.

MATERIALS AND FEATURES:

Body: zinc-plated steel.

Internal parts: hardened and ground steel.

Seals: BUNA N standard

Poppet type: minor leakage

APPLICATIONS:

Flange M1 and M2 directly to the motor and connect ports V1 and V2 to pressure flow.

ON REQUEST:

- different setting range (see the table)
- other setting available (CODE/T: please specify the desired setting)
- brake unclaping (CODE/ SF)

PRESSIONE/PORTATA
PRESSURE/FLOW

Temperatura olio: 50°C - Viscosità olio: 30 cSt
Oil temperature: 50°C - Oil viscosity: 30 cSt

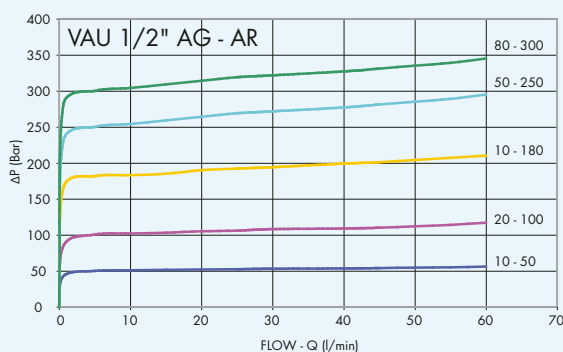



CODICE
CODE

SIGLA
TYPE

PORTATA MAX
MAX FLOW
Lt./min

V0455

VAU 1/2" AG - AR

60

DXF

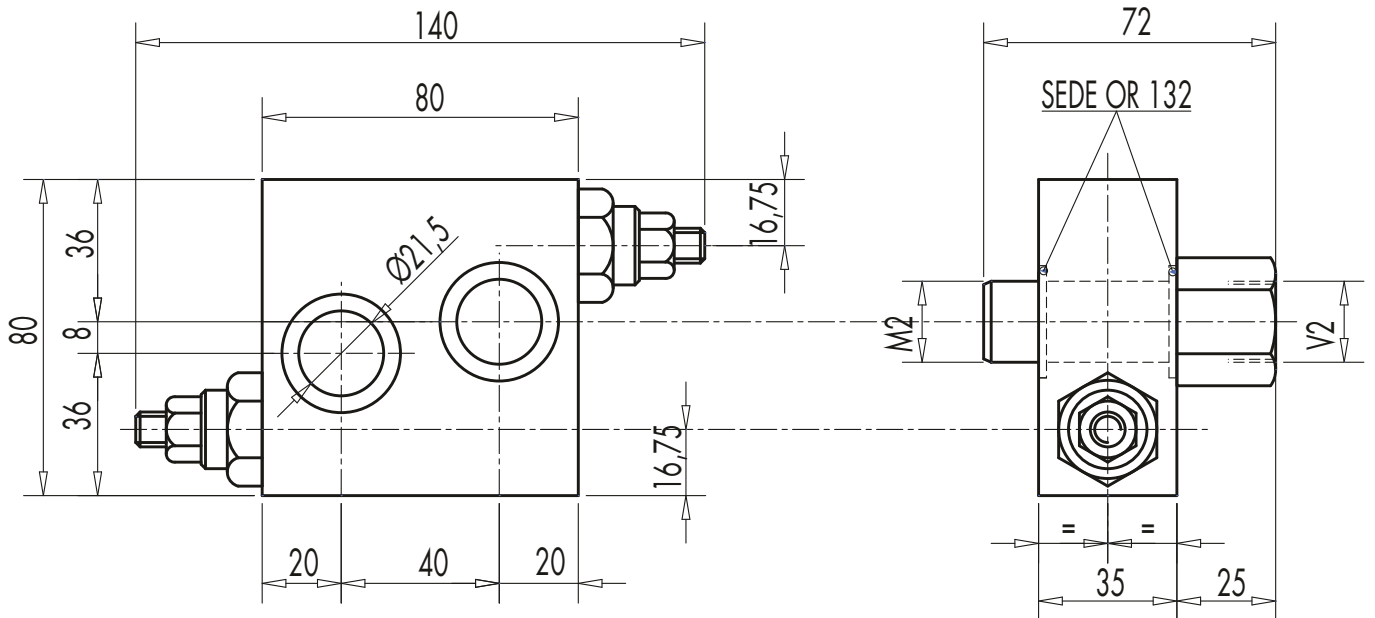

5

CODICE
CODE

SIGLA
TYPE

V1 - V2

PESO
WEIGHT

V0455

VAU 1/2" AG - AR

GAS

Kg

G 1/2"

1,480

MOLLE • SPRINGS

Campo di taratura Setting range (bar)	Incremento bar per giro Pressure increase (bar/turn) Q = 4 l/min	Taratura standard Standard setting (bar)
10 - 50*	7	30
20 - 100	12	75
10 - 180 STANDARD	30	90
50 - 250	45	130
80 - 300	50	150

*Per tarature inferiori a 70 Bar: Q = 12 l/min *For setting less than 70 Bar: Q = 12 l/min

REGOLAZIONE - ADJUSTEMENT

CODICE/V • CODE/V	Volantino Handknob
CODICE/PP • CODE/PP	Predisposizione alla piombatura Arranged for sealing cap
CODICE/P • CODE/P	Piombatura Sealing cap





5.6 - VALVOLE ANTIURTO CON ANTICAVITAZIONE

5.6 - DUAL CROSS RELIEF VALVES WITH ANTI-CAVITATION

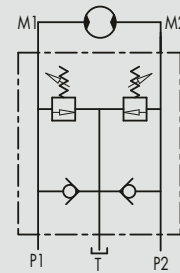
TIPO/TYPE
VAUACSCHEMA IDRAULICO
HYDRAULIC DIAGRAM**IMPIEGO:**

Valvola utilizzata per limitare la pressione in entrambi i rami di un motore idraulico: al raggiungimento di un determinato valore di taratura la valvola si apre e scarica in T. La presenza delle valvole di ritegno impedisce eventi di cavitazione quando il carico di rotazione diventa trainante all'urto. Si consiglia di montare valvole di ritegno tarate all'uscita dello scarico.

MATERIALI E CARATTERISTICHE:

Corpo: acciaio zincato (VAUAC 1/2") e alluminio (VAUAC 3/4")
Componenti interni: acciaio temprato termicamente e rettificato
Guarnizioni: BUNA N standard
Tenuta: a cono guidato. Trafilamento trascurabile

MONTAGGIO:

Collegare M1 e M2 al motore e le P1 e P2 all'alimentazione. Collegare T allo scarico. Si raccomanda il montaggio vicino all'attuatore per limitare le perdite di carico e ottenere un pronto funzionamento.

A RICHIESTA:

- Molle per diversi campi di taratura (vedi tabella)
- Pressione di taratura diversa da quella standard (CODICE/T specificando il valore di taratura)

PRESSIONE/PORTATA
PRESSURE/FLOW**USE AND OPERATION**

This valve is used to block pressure to a certain setting in the 2 ports of an hydraulic motor: when it reaches pressure setting, the valve opens allowing pressure relief in T. The relief valve provides overload protection in a fast and accurate way and cavitation is avoid tanks to the check valve. It's suggested to mount set check valves to the tank way out.

MATERIALS AND FEATURES:

Body: zinc-plated steel (VAUAC 1/2") and aluminium (VAUAC 3/4")
Internal parts: hardened and ground steel.
Seals: BUNA N standard
Poppet type: minor leakage

APPLICATIONS:

Connect M1 and M2 to the motor and P1 and P2 to the pressure flow. Connect T to the tank. Mounting by the actuator is highly recommended in order to avoid pressure drops and get a prompt duty.

ON REQUEST:

- different setting range (see the table)
- other setting available (CODICE/T: please specify the desired setting)

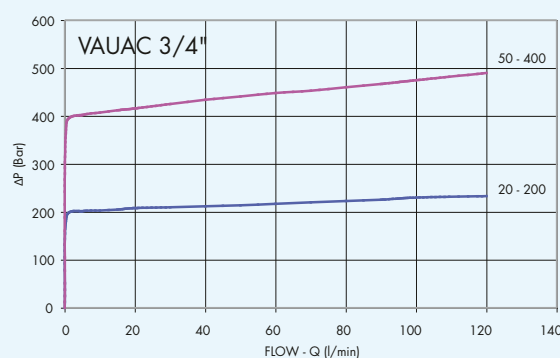
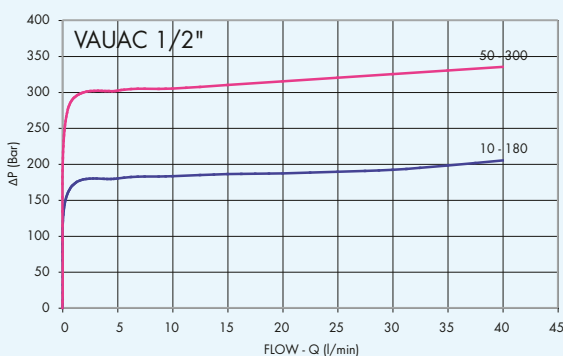
Temperatura olio: 50°C - Viscosità olio: 30 cSt
Oil temperature: 50°C - Oil viscosity: 30 cSt



CODICE
CODE

SIGLA
TYPE

PORTATA MAX
MAX FLOW
Lt./min

V0508

VAUAC 1/2"

70

V0510

VAUAC 3/4"

110

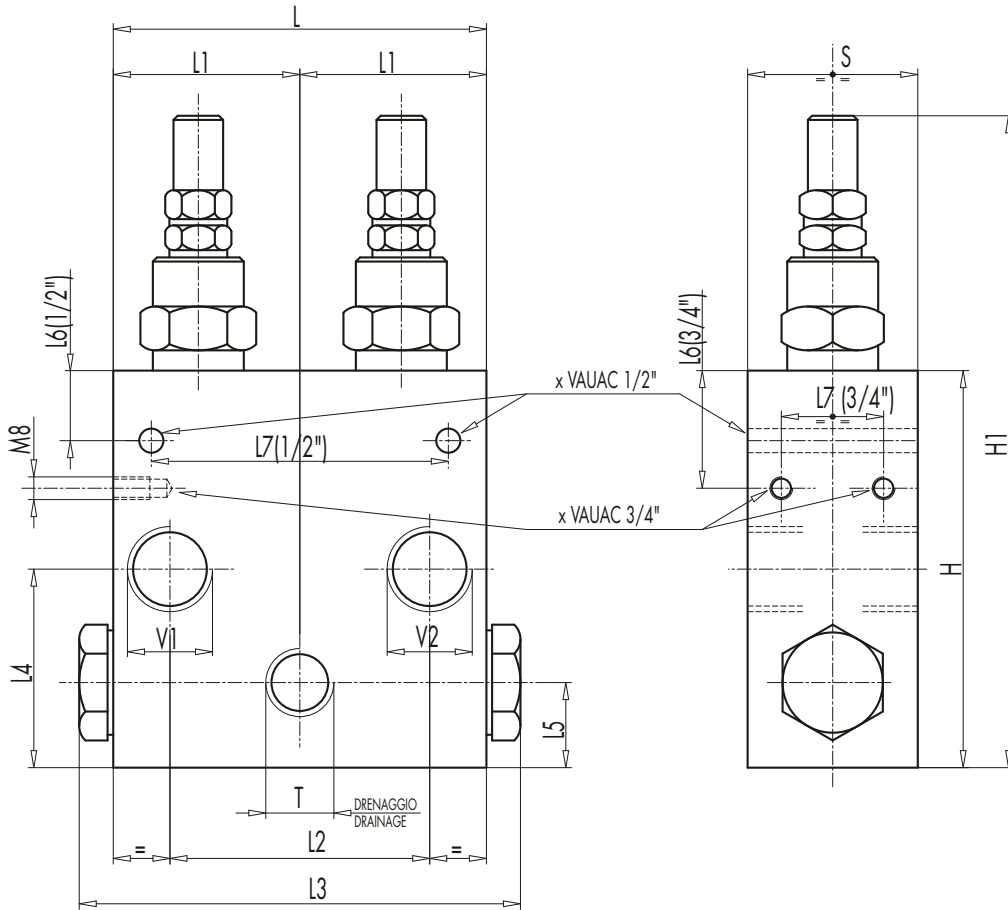

DXF

5

CODICE CODE	SIGLA TYPE	V1-V2	T	L	L1	L2	L3	L4	L5	L6	L7	H	H1	S	PESO WEIGHT
		GAS	GAS	mm	mm	mm	mm	mm	mm	mm	mm	mm	mm	mm	Kg
V0508	VAUAC 1/2"	G 1/2"	G 3/8"	80	40	38	102	40	16	42	67	112	174	35	2,254
V0510	VAUAC 3/4"	G 3/4"	G 1/2"	110	55	64	132	58	23	36	38	120	182	50	2,534

MOLLE • SPRINGS (VAUAC 1/2")

Campo di taratura Setting range (bar)	Incremento bar per giro Pressure increase (bar/turn) Q = 4 l/min	Taratura standard Standard setting (bar)
10 – 180 STANDARD	30	90
80 – 300	50	150

MOLLE • SPRINGS (VAUAC 3/4")

Campo di taratura Setting range (bar)	Incremento bar per giro Pressure increase (bar/turn) Q = 4 l/min	Taratura standard Standard setting (bar)
20 – 200	40	160
50 – 400 STANDARD	80	180

REGOLAZIONE - ADJUSTEMENT

CODICE/V • CODE/V Volantino
Handknob

CODICE/PP • CODE/PP Predisposizione alla piombatura
Arranged for sealing cap

CODICE/P • CODE/P Piombatura
Sealing cap





5.7 - VALVOLA DI BLOCCO E ANTIURTO

5.7 - DUAL CROSS RELIEF VALVE WITH PILOT CHECK VALVE

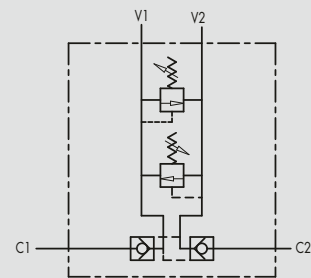
TIPO/TYPE
VBAUSCHEMA IDRAULICO
HYDRAULIC DIAGRAM**IMPIEGO:**

Valvola formata dall'unione di una valvola di ritegno doppia pilotata e da una valvola limitatrice di pressione doppia incrociata. Oltre al blocco dell'attuatore consente la limitazione della pressione in entrata all'attuatore.

MATERIALI E CARATTERISTICHE:

Corpo: acciaio zincato
Componenti interni: acciaio temprato termicamente e rettificato
Guarnizioni: BUNA N standard
Tenuta: a cono guidato. Trafilamento trascurabile

MONTAGGIO:

Collegare V1 e V2 all'alimentazione e C1 e C2 all'attuatore.

A RICHIESTA:

- Pressione di taratura diversa da quella standard (CODICE/T specificando il valore di taratura)

USE AND OPERATION:

Made up by 1 double pilot check valve together with one double cross relief valve, this valve enables to block the actuator in one position and to limit inlet pressure to the actuator.

MATERIALS AND FEATURES:

Body: zinc-plated steel.
Internal parts: hardened and ground steel.
Seals: BUNA N standard
Poppet type: minor leakage

APPLICATIONS:

Connect V1 and V2 to the pressure flow and C1 and C2 to the actuator.

ON REQUEST:

- other setting available (CODE/T: please specify the desired setting)

PERDITE DI CARICO
PRESSURE DROPS CURVE

Temperatura olio: 50°C - Viscosità olio: 30 cSt
 Oil temperature: 50°C - Oil viscosity: 30 cSt

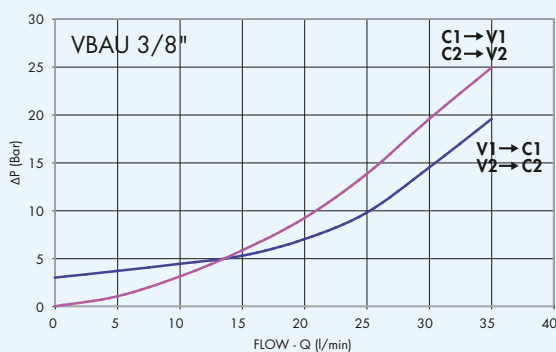



CODICE
CODE

SIGLA
TYPE

PORTATA MAX
MAX FLOW
Lt./min

V0444

VBAU 3/8"

35

DXF

5

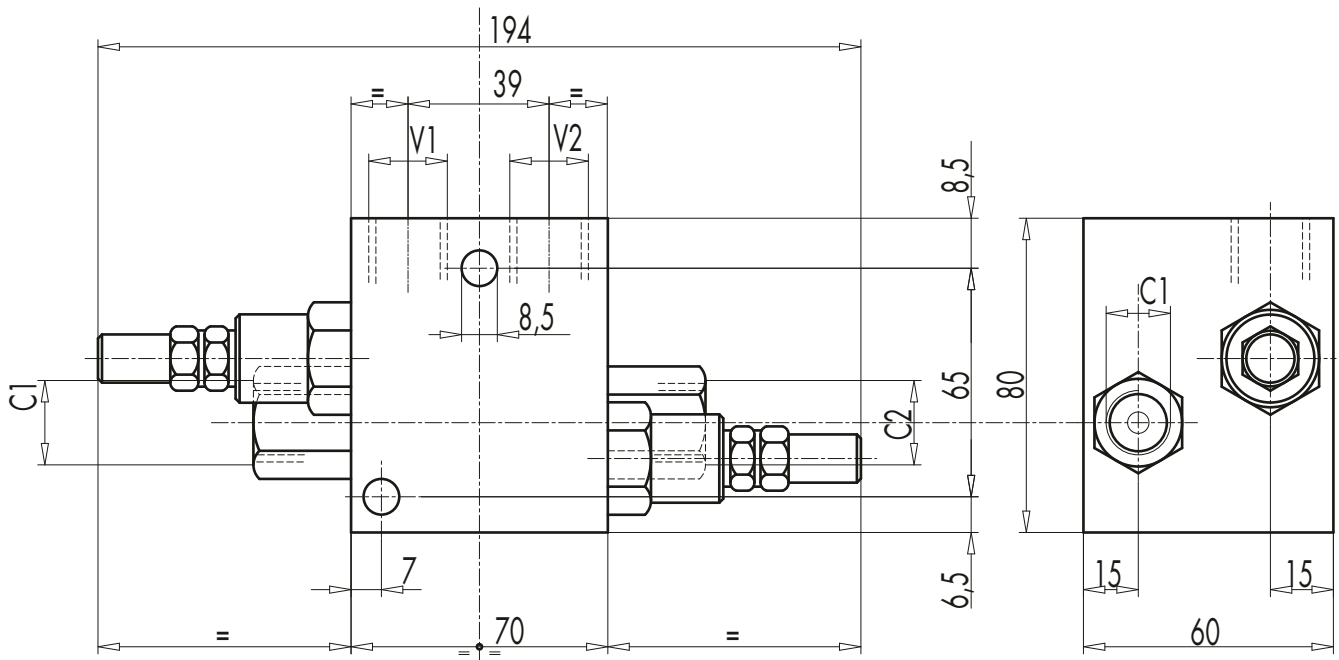

CODICE
CODE

SIGLA
TYPE

V1 - V2
C1 - C2

PESO
WEIGHT

V0444

VBAU 3/8"

GAS
G 3/8"

Kg
2,534

MOLLE • SPRINGS

Campo di taratura Setting range (bar)	Incremento bar per giro Pressure increase (bar/turn) Q = 4 l/min	Taratura standard Standard setting (bar)
10 - 180	40	100

REGOLAZIONE - ADJUSTEMENT

CODICE/V • CODE/V	Volantino Handknob
CODICE/PP • CODE/PP	Predisposizione alla piombatura Arranged for sealing cap
CODICE/P • CODE/P	Piombatura Sealing cap

