



VALVOLE EQUILIBRATRICI A 2 VIE
2 WAYS FLOW DIVIDER





8.1 - VALVOLE EQUILIBRATRICI A 2 VIE

8.1 - 2 WAYS FLOW DIVIDER

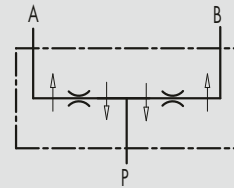
TIPO/TYPE
V-EQSCHEMA IDRAULICO
HYDRAULIC DIAGRAM

IMPIEGO:

Valvole che consentono la divisione del fluido in ingresso in due parti uguali (50/50), mentre nella direzione opposta lo riunificano indipendentemente dalla variazione di pressione generata dagli attuatori e dalla loro portata. Vengono utilizzate quando due attuatori uguali, non accoppiati meccanicamente, alimentati dalla stessa pompa e regolati dallo stesso distributore, devono muoversi contemporaneamente in entrata e in uscita.

MATERIALI E CARATTERISTICHE:

Corpo: ghisa / acciaio

Componenti interni: acciaio temprato termicamente e rettificato

Guarnizioni: BUNA N standard e Teflon

Tenuta: per accoppiamento. Trafilamento trascurabile

Tolleranza: < 2% sulla corsa. Eventuali differenze sono compensate a fine corsa del cilindro.

MONTAGGIO:

Collegare P all'alimentazione e A e B agli attuatori.

USE AND OPERATION:

These valves allows the division of inlet flow into two equals parts (50/50) and they unify it in the reverse direction independently of any pressure changes and flow. These valves are used when two equal actuators, that are not mechanically coupled, supplied by the same pump and controlled by a single distributor, must move simultaneously both at input and output.

MATERIALS AND FEATURES:

Body: cast iron / steel

Internal parts: hardened and ground steel

Seals: BUNA N standard and Teflon

Tightness: by diameter combination. Minor leakage
Cylinder stroke error tolerance of 2%. Any synchronisation differences are compensated by the terminal position of the stroke.

APPLICATIONS:

Connect P to pressure flow and A and B to the actuators.





CODICE CODE	SIGLA TYPE	PORTATA MIN.* MIN. FLOW Lt./min	PORTATA MAX.* MAX FLOW Lt./min	PRESS. ESERCIZIO WORKING PRESSURE Bar	PICCO DI PRESSIONE PEAK PRESSURE Bar
V1001	V - EQ 8	1	3	250	300
V1000	V - EQ 10	3	6	250	300
V1002	V - EQ 15	6	10	250	300
V1003	V - EQ 20	10	20	250	300
V1004	V - EQ 22	20	32	250	300
V1005	V - EQ 25	25	40	250	300
V1006	V - EQ 30	40	60	250	300
V1007	V - EQ 50	60	80	250	300

*I valori di portata si riferiscono all'ingresso P
*Capacity values refers to input P

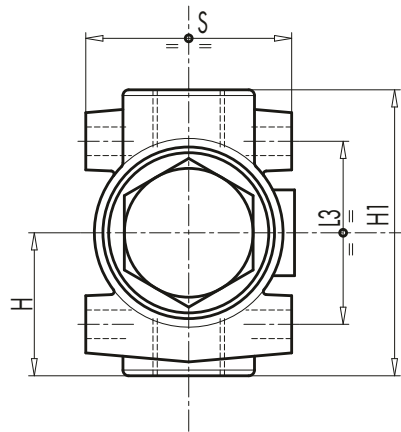
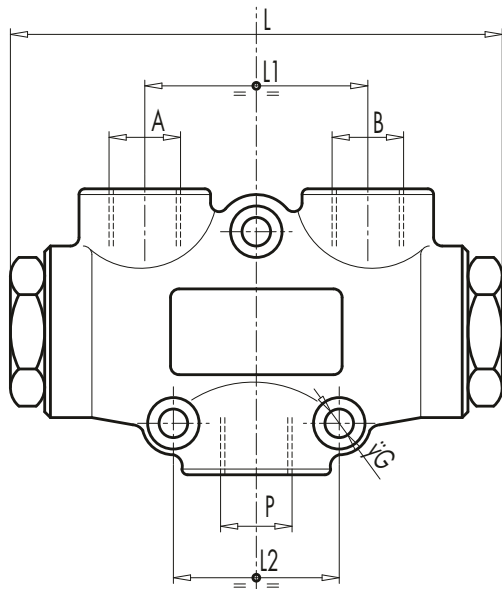

CODICE CODE	SIGLA TYPE	P	A - B	L	L1	L2	L3	ØG	H	H1	S	PESO WEIGHT
		GAS	GAS	mm	mm	mm	mm	mm	mm	mm	mm	Kg
V1001	V - EQ 8	G 3/8"	G 3/8"	117	53	40	45	7	35	68	48	1,27
V1000	V - EQ 10											1,27
V1002	V - EQ 15											1,28
V1003	V - EQ 20											1,27
V1004	V - EQ 22	G 1/2"	G 3/8"	117	53	40	45	7	35	68	48	1,28
V1005	V - EQ 25											1,28
V1006	V - EQ 30											1,26
V1007	V - EQ 50											1,26

