



VALVOLE FINECORSA
END STROKE VALVES





13.1 - FINECORSA IN TRAZIONE E SPINTA NORMALMENTE APERTO

TIPO/TYPE
V-FCR 1T

13.1 - END STROKE VALVES, NORMALLY OPENED



SCHEMA IDRAULICO
HYDRAULIC DIAGRAM

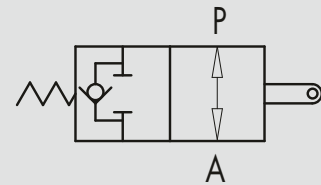

IMPIEGO:

Valvola utilizzata per bloccare l'immissione di olio in un circuito idraulico o per fermare la corsa di un attuatore (valvola normalmente aperta). La chiusura della valvola, ottenuta azionando il cursore in trazione o spinta, permette un arresto immediato e totale del flusso di olio.

MATERIALI E CARATTERISTICHE:

Corpo: ghisa

Componenti interni: acciaio temprato termicamente e rettificato

Guarnizioni: BUNA N standard

Tenuta: trafileamento trascurabile

MONTAGGIO:

Collegare P al distributore e A al circuito o all'attuatore. Con il cursore azionato il flusso è bloccato da P ad A mentre, nella direzione opposta, la valvola di ritegno permette il libero passaggio dell'olio da A a P.

USE AND OPERATION:

This valve is used to stop oil inlet in a hydraulic circuit or to stop actuator's stroke (normally opened valve). The valve closing, obtained by pulling or pushing the slider, allows an immediate and total stop of the oil flow.

MATERIAL AND FEATURES

Body: cast iron

Internal parts: grounded and hardened steel

Seals: BUNA N standard

Tightness: minor leakage

APPLICATIONS:

Connect P to the distributor and A to the circuit or to the actuator. When slider is operating, flow is blocked from P towards A, whilst the check valve enables free oil flow in the reverse direction (from A towards P).

PERDITE DI CARICO PRESSURE DROPS CURVE

Temperatura olio: 50°C - Viscosità olio: 30 cSt
Oil temperature: 50°C - Oil viscosity: 30 cSt

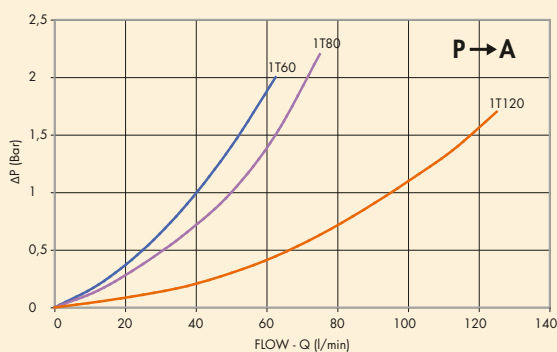



CODICE CODE	SIGLA TYPE	PORTATA MAX MAX FLOW Lt./min	PRESSIONE MAX MAX PRESSURE Bar
V0824	VFCR 1T 60	60	350
V0826	VFCR 1T 80	80	350
V0825	VFCR 1T 120	120	350

VFCR 1T 60 - 80

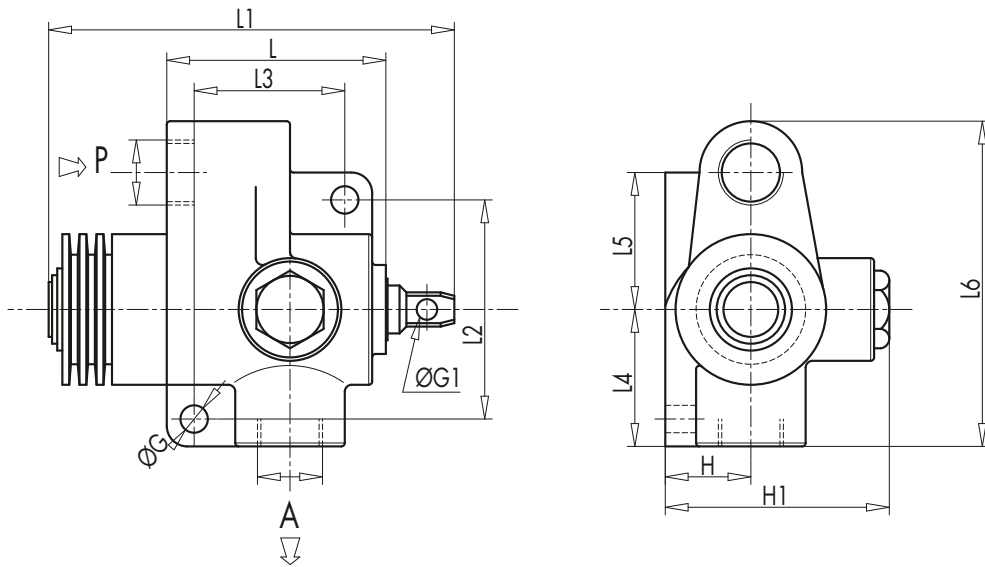

DXF

VFCR 1T 120

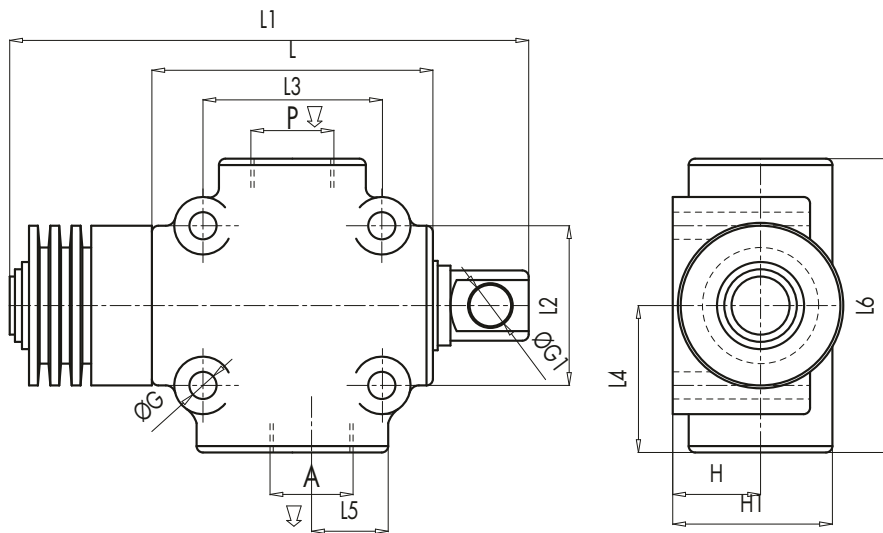

DXF

CODICE CODE	SIGLA TYPE	A - P	L	L1	L2	L3	L4	L5	L6	ØG	ØG1	H	H1	PESO WEIGHT
		GAS	mm	mm	mm	mm	mm	mm	mm	mm	mm	mm	mm	Kg
V0824	VFCR 1T 60	G 3/8"	69	130	66	45	45	41	103	8,5	6,5	26	68	1,628
V0826	VFCR 1T 80	G 1/2"	69	130	66	45	45	41	103	8,5	6,5	26	68	1,616
V0825	VFCR 1T 120	G 3/4"	88	173	50	56	46	23,5	92	8,5	13	27,5	50	2,112





13.2 - FINECORSA IN TRAZIONE E SPINTA NORMALMENTE CHIUSO

TIPO/TYPE
V-FCR 2T

13.2 - END STROKE VALVES, NORMALLY CLOSED



SCHEMA IDRAULICO
HYDRAULIC DIAGRAM

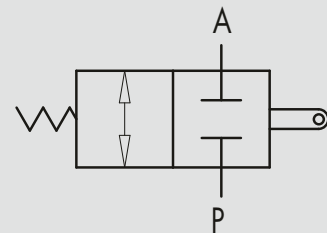

IMPIEGO:

Valvola utilizzata per aprire il passaggio di olio in un circuito idraulico (valvola normalmente chiusa). L'apertura della valvola è ottenuta azionando il cursore in trazione o spinta.

MATERIALI E CARATTERISTICHE:

Corpo: ghisa

Componenti interni: acciaio temprato termicamente e rettificato

Guarnizioni: BUNA N standard

Tenuta: trafilamento trascurabile

MONTAGGIO:

Collegare A e P indifferentemente al distributore e al circuito. Quando il cursore è azionato il flusso è libero in entrambe le direzioni, viceversa il flusso è bloccato.

USE AND OPERATION:

This valve is used to enable oil inlet in a hydraulic circuit (normally closed valve). The valve opens by pulling or pushing the slider.

MATERIAL AND FEATURES

Body: cast iron

Internal parts: grounded and hardened steel

Seals: BUNA N standard

Tightness: minor leakage

APPLICATIONS:

Connect independently A and P to the distributor and to the circuit. When slider is operating, flow is free in both directions, vice versa it is blocked.

PERDITE DI CARICO PRESSURE DROPS CURVE

Temperatura olio: 50°C - Viscosità olio: 30 cSt
Oil temperature: 50°C - Oil viscosity: 30 cSt

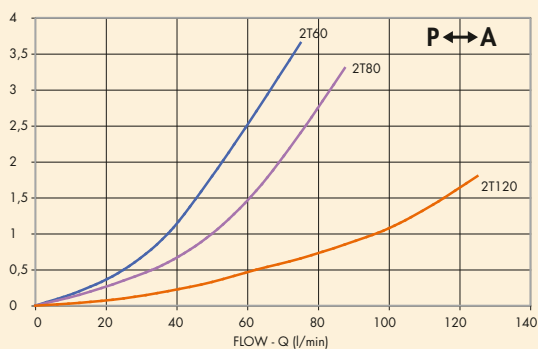



CODICE CODE	SIGLA TYPE	PORTATA MAX MAX FLOW Lt./min	PRESSIONE MAX MAX PRESSURE Bar
V0820	VFCR 2T 60	60	350
V0822	VFCR 2T 80	80	350
V0823	VFCR 2T 120	120	350

VFCR 2T 60 - 80

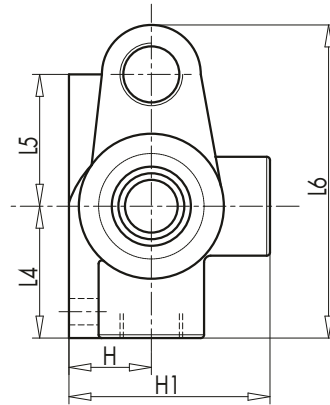
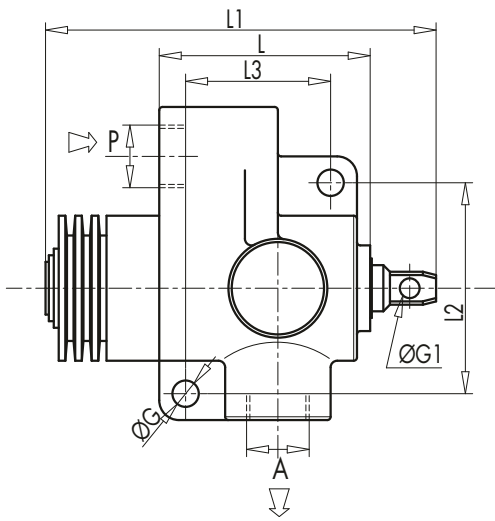

DXF

VFCR 2T 120

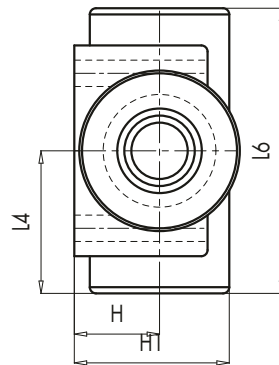
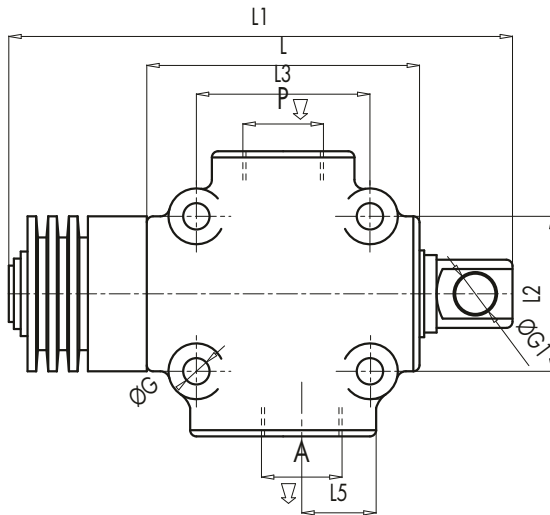

DXF

CODICE CODE	SIGLA TYPE	A - P	L	L1	L2	L3	L4	L5	L6	ØG	ØG1	H	H1	PESO WEIGHT
		GAS	mm	mm	mm	mm	mm	mm	mm	mm	mm	mm	mm	Kg
V0820	VFCR 2T 60	G 3/8"	69	130	66	45	45	41	103	8,5	6,5	26	68	1,648
V0822	VFCR 2T 80	G 1/2"	69	130	66	45	45	41	103	8,5	6,5	26	68	1,652
V0823	VFCR 2T 120	G 3/4"	88	179	50	56	46	23,5	92	8,5	13	27,5	50	2,204





13.3 - FINECORSA A PULSANTE NORMALMENTE CHIUSO

TIPO/TYPE
VF-NC

13.3 - PUSHBUTTON END STROKE VALVES, NORMALLY CLOSED



SCHEMA IDRAULICO
HYDRAULIC DIAGRAM

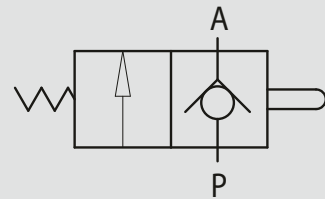

IMPIEGO:

Valvola utilizzata per aprire il passaggio di olio in un circuito idraulico (valvola normalmente chiusa). Una volta azionato meccanicamente il cursore, si ha il libero passaggio dell'olio da P a A. Può avere principalmente due impieghi:

- per azionare la sequenza di due attuatori;
- come valvola di fine corsa, con flusso direttamente collegato allo scarico.

MATERIALI E CARATTERISTICHE:

Corpo: acciaio

Componenti interni: acciaio temprato termicamente e rettificato

Guarnizioni: BUNA N standard

Tenuta: a sfera. Trafilamento nullo

Corsa massima del cursore: 13 mm

Apertura immediata

MONTAGGIO:

Collegare P alla linea di utilizzo e A direttamente allo scarico. Lo schema di montaggio può variare in base al servizio richiesto.

USE AND OPERATION:

This valve allows oil passage in a hydraulic circuit (normally closed valve). Once the slider is set into action, oil flow is free from P to A. It can be used:

- to set the sequence of 2 actuators;
- as end strokes valve, where flow is directly connected to the tank.

MATERIALS AND FEATURES

Body: zinc-plated steel

Internal parts: grounded and hardened steel

Seals: BUNA N standard

Ball type: any leakage

Maximum stroke: 13 mm

Prompt opening

APPLICATIONS:

Connect A directly to the tank and P as for necessity. Mounting scheme can vary according to the use.

PERDITE DI CARICO PRESSURE DROPS CURVE

Temperatura olio: 50°C - Viscosità olio: 30 cSt
Oil temperature: 50°C - Oil viscosity: 30 cSt

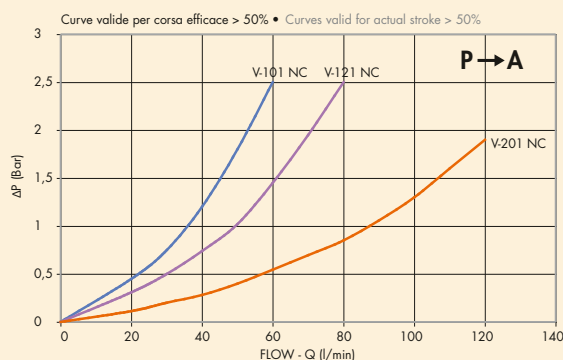



CODICE
CODE

SIGLA
TYPE

PORTATA MAX
MAX FLOW
Lt./min

PRESSIONE MAX
MAX PRESSURE
Bar

V0827	V - 101 3/8" NC	40	350
V0828	V - 121 1/2" NC	60	350
V0829	V - 201 3/4" NC	100	350

DXF

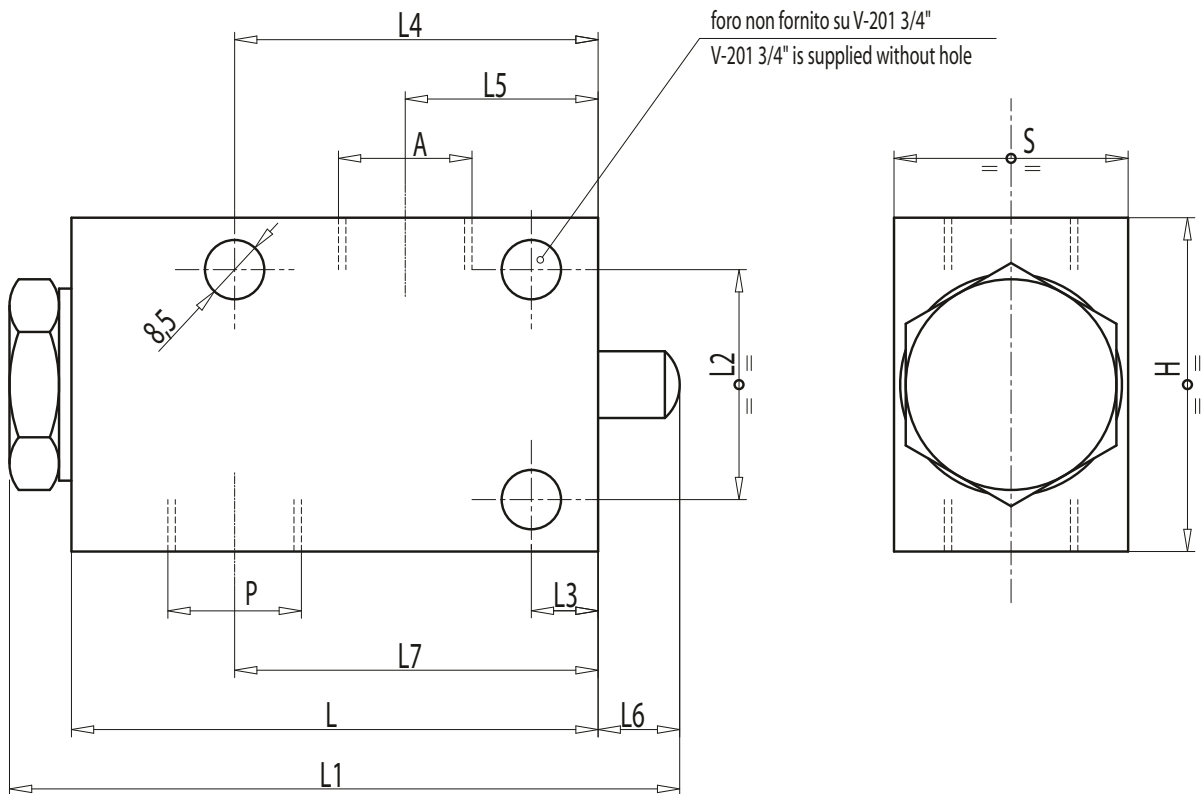

13

CODICE CODE	SIGLA TYPE	A - P	L	L1	L2	L3	L4	L5	L6	L7	H	S	PESO WEIGHT
		GAS	mm	mm	mm	mm	mm	mm	mm	mm	mm	mm	Kg
V0827	V - 101 3/8" NC	G 3/8"	80	105	35	10	55	30	14	55	50	35	0,962
V0828	V - 121 1/2" NC	G 1/2"	80	105	35	10	55	28,5	14	55	50	35	0,934
V0829	V - 201 3/4" NC	G 3/4"	88	115	50	20	68	23	14	61	70	45	0,860



13



13.4 - FINECORSA A PULSANTE NORMALMENTE APERTO

13.4 - PUSHBUTTON END STROKE VALVES, NORMALLY OPENED

TIPO/TYPE
VF-NA



SCHEMA IDRAULICO
HYDRAULIC DIAGRAM

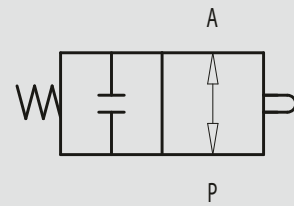

IMPIEGO:

Valvola utilizzata per chiudere il passaggio di olio in un circuito idraulico (valvola normalmente aperta). La chiusura della valvola è ottenuta spingendo meccanicamente il cursore.

MATERIALI E CARATTERISTICHE:

Corpo: acciaio

Componenti interni: acciaio temprato termicamente e rettificato

Guarnizioni: BUNA N standard

Tenuta: trafilamento trascurabile

Corsa massima del cursore: 15 mm

Chiusura dopo 4 mm di corsa

MONTAGGIO:

Collegare A e P indifferentemente al distributore e al circuito. Quando il cursore è azionato il flusso è bloccato in entrambe le direzioni, viceversa il flusso è libero.

USE AND OPERATION:

This valve is used to block oil passage in a hydraulic circuit (normally opened valve). The valve closes by pushing mechanically the slider.

MATERIALS AND FEATURES

Body: zinc-plated steel

Internal parts: grounded and hardened steel

Seals: BUNA N standard

Ball type: minor leakage

Maximum stroke: 15 mm

Closing after 4 mm stroke

APPLICATIONS:

Connect independently A or P to the distributor and to the circuit. When slider is operating flow is blocked in both direction, vice versa it is free.

PERDITE DI CARICO PRESSURE DROPS CURVE

Temperatura olio: 50°C - Viscosità olio: 30 cSt
Oil temperature: 50°C - Oil viscosity: 30 cSt

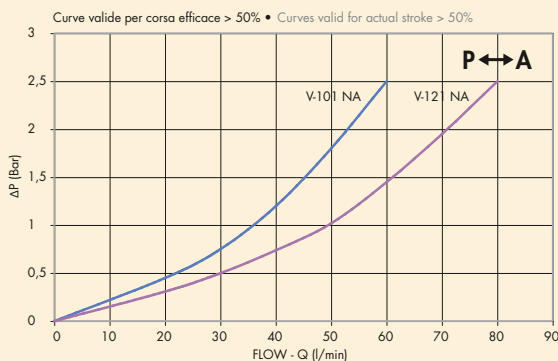



CODICE CODE	SIGLA TYPE	PORTATA MAX MAX FLOW Lt./min	PRESSIONE MAX MAX PRESSURE Bar
V0817	V - 101 3/8" NA	35	350
V0818	V - 121 1/2" NA	50	350

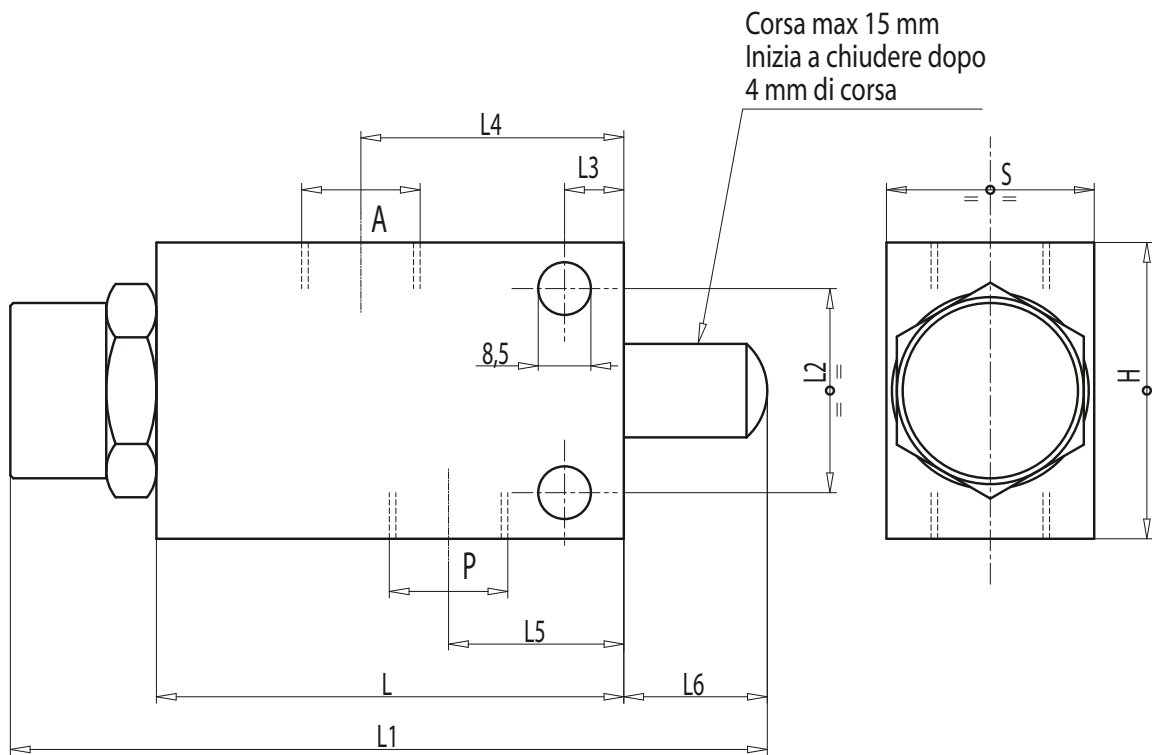

CODICE CODE	SIGLA TYPE	A - P	L	L1	L2	L3	L4	L5	L6	H	S	PESO WEIGHT
		GAS	mm	mm	mm	mm	mm	mm	mm	mm	mm	Kg
V0817	V - 101 3/8" NA	G 3/8"	80	129	35	8	45	30	24	56	35	1,24
V0818	V - 121 1/2" NA	G 1/2"	80	129	35	8	45	30	24	62	35	1,38

