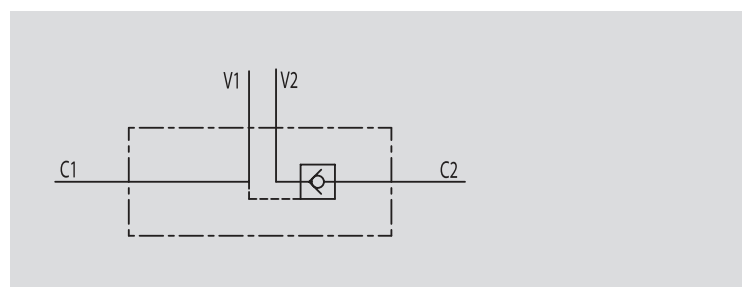
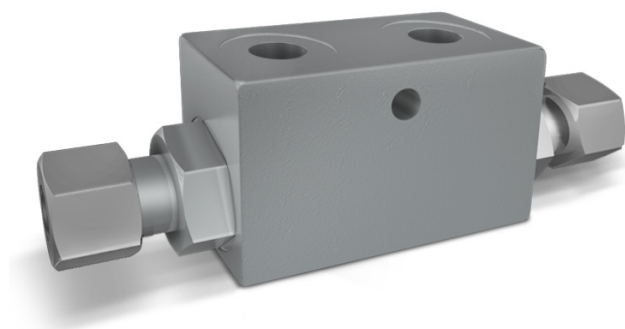

VALVOLE DI BLOCCO PILOTATE A SEMPLICE EFFETTO CON CARTUCCE EXTRACORTE DIN 2353

TIPO / TYPE

VBPSE 2 CEXCSCHEMA IDRAULICO
HYDRAULIC DIAGRAM

SINGLE PILOT OPERATED CHECK VALVES FOR 12 mm PIPE MOUNTING (DIN 2353)

IMPIEGO:

Valvola utilizzata per bloccare in posizione un cilindro in un solo senso, consentendo il flusso in una direzione ed impedendolo in senso contrario fino a quando non viene applicata la pressione di pilotaggio. Questa valvola risulta particolarmente adatta per il montaggio su cilindro. A richiesta si fornisce kit raccordi a misura per il montaggio a interesse definito.

MATERIALI E CARATTERISTICHE:

Corpo: acciaio zincato
Componenti interni: acciaio temprato termicamente e rettificato
Guarnizioni: BUNA N standard
Tenuta: a cono guidato. Non ammette trafileamenti

MONTAGGIO:

Collegare V1 e V2 all'alimentazione, C1 al lato dell'attuatore con flusso libero e C2 al lato dell'attuatore dove si desidera la tenuta

A RICHIESTA

- senza guarnizione OR sul pilota
- senza dado e ogiva
- molla 1 Bar
- molla 8 Bar

PERDITE DI CARICO

PRESSURE DROPS CURVE

USE AND OPERATION:

These valves are used to block the cylinder in one direction. The flow is free in one direction and blocked in the reverse direction until pilot pressure is applied. They are easily assembled on cylinders. Specific distance-centre mounting fittings kit on request.

MATERIALS AND FEATURES:

Body: zinc-plated steel.
Internal parts: hardened and ground steel.
Seals: BUNA N standard
Poppet type: any leakage.

APPLICATIONS:

Connect V1 and V2 to the pressure flow, C1 to the free flow side of the actuator and C2 to the actuator's side you want the flow to be blocked.

ON REQUEST

- without seal on pilot piston
- without nut and olive
- 1 Bar spring
- 8 Bar spring

Temperatura olio: 50°C - Viscosità olio: 30 cSt

Oil temperature: 50° C - Oil viscosity: 30 cSt

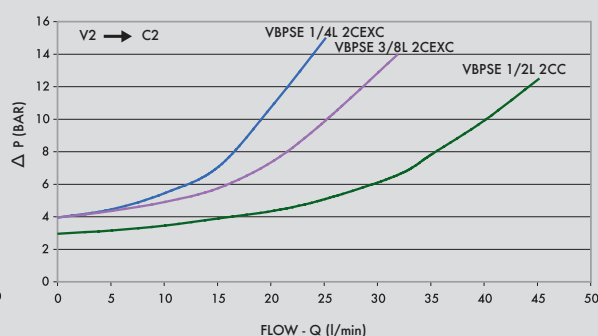
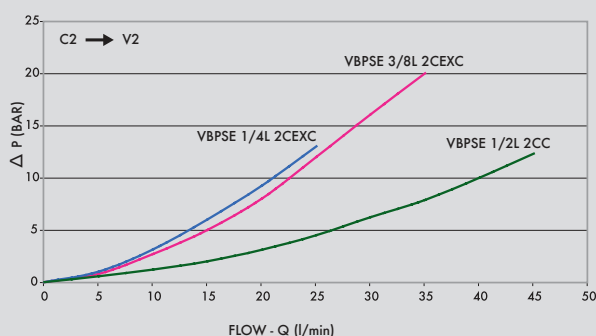



CODICE CODE	SIGLA TYPE	RAPP. PILOT PILOT RATIO	PORTATA MAX MAX FLOW Lt. / min	PRESSIONE MAX MAX PRESSURE Bar	PRESSIONE APERTURA CRACKING PRESSURE Bar
V0090/SE	VBPSE 1/4" L 2 CEXC	1:5,5	20	350	4
V0110/SE	VBPSE 3/8" L 2 CEXC	1:5,5	30	350	4
V0135/SE	VBPSE 1/2" L 2 CC	1:5	50	350	3

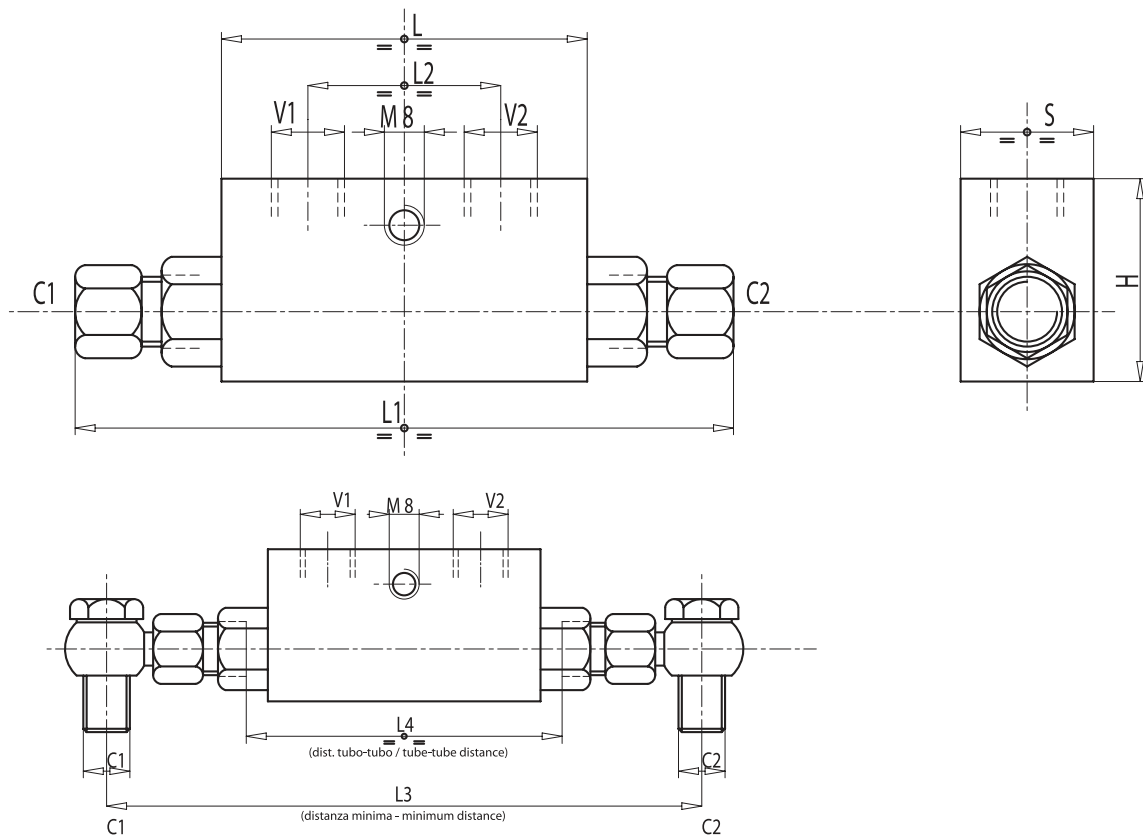

CODICE CODE	SIGLA TYPE	V1 - V2 GAS	C1 - C2 mm	L mm	L1 mm	L2 mm	L3 mm	L4 mm	H mm	S mm	PESO WEIGHT kg
V0090/SE	VBPSE 1/4" L 2 CEXC	G 1/4"	12L	64	130	36	160	84	40	30	0,638
V0110/SE	VBPSE 3/8" L 2 CEXC	G 3/8"	12L	64	130	36	166	84	40	30	0,620
V0135/SE	VBPSE 1/2" L 2 CC	G 1/2"	15L	90	164	45	196	106	45	35	1,088