

SECTIONAL DIRECTIONAL  
CONTROL VALVES

SD 8

DS 8



 **walvoil**  
HYDRAULIC CONTROL SYSTEMS

### **SD8**

Simple, compact and heavy duty designed sectional valve from 1 to 12 sections for open and closed centre hydraulic systems.

Fitted with a main pressure relief valve and a load check valve on every working section

Available with parallel, tandem or series circuit.

Optional carry-over port.

A wide variety of port and circuit valves.

Available manual, pneumatic, hydraulic, electro-hydraulic, and remote with flexible cables spool control kits.

Diameter 18 mm (0.71 in) interchangeable spools.

### **DLS8**

These directional valves are fitted with flow control valve in the inlet section and need the SD8 working sections

They are for systems with fixed displacement pumps (open centre version), or variable displacement pumps (closed centre version), with Load-Sensing signal on each working section to pump flow control valve control.

Ports valves and control kits are the same of SD8 directional valve.

#### **Additional information**

This catalogue shows the product in the most standard configurations.

Please contact Sales Dpt. for more detailed information or special request.

#### **WARNING!**

All specifications of this catalogue refer to the standard product at this date.

Walvoil, oriented to a continuous improvement, reserves the right to discontinue, modify or revise the specifications, without notice.

WALVOIL IS NOT RESPONSIBLE FOR ANY DAMAGE CAUSED BY AN  
INCORRECT USE OF THE PRODUCT.

1<sup>st</sup> edition December 2002

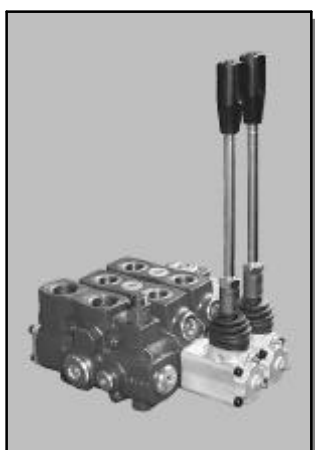

### SD8 contents

Working conditions	4
Dimensional data	5
Hydraulic circuit	6
Performance data	9
Ordering codes	12
Inlet cover	
ordering codes	14
inlet cover body and hydraulic circuit	13
inlet relief options	14
inlet valve options	16
R2 commutator configuration	17
Working section	
ordering codes	18
working section kit and hydraulic circuit	20
spools	21
Intermediate section	
CS mid return manifold sections	27
DFG compensated flow divider section	28
EI service relief valve sections	29
Outlet section	
ordering codes	30
outlet cover body and hydraulic circuit	31

### DLS8 contents

Working conditions	32
Dimensional data	33
Hydraulic circuit	34
Performance data	35
Ordering codes	36
Inlet and outlet cover	
ordering codes	38
inlet and outlet cover kit and hydraulic circuit	39
inlet relief options	41
Working section	
ordering codes	42
working section kit and hydraulic circuit	20
spools	44
Return cover	47

### Common parts contents

Spool controls	
“A” side spool positioners	48
“B” side options	57
complete controls	60
Ports valves	64
Installation and maintenance	67
Accessories	70

## Working conditions

This catalogue shows technical specifications and diagrams measured with mineral oil of 46 mm<sup>2</sup>/s - 46 cSt viscosity at 40°C temperature.

Nominal flow rating		80 l/min	
Operating pressure (maximum)		315 bar	4600 psi
Back pressure (maximum)	<i>on outlet port T</i>	25 bar	360 psi
Internal leakage A(B)→T	<i>Δp=100 bar - 1450 psi fluid and valve at 40°C</i>	3 cm <sup>3</sup> /min	0.18 in <sup>3</sup> /min
Fluid		Mineral base oil	
Fluid temperature	<i>with NBR (BUNA-N) seals</i>	from -20° to 80°C	
	<i>with FPM (VITON) seals</i>	from -20° to 100°C	
Viscosity	<i>operating range</i>	from 15 to 75 mm <sup>2</sup> /s	<i>from 15 to 75 cSt</i>
	<i>min.</i>	12 mm <sup>2</sup> /s	12 cSt
	<i>max.</i>	400 mm <sup>2</sup> /s	400 cSt
Max level of contamination		19/16 - ISO 4406	
Ambient temperature		from -40° to 60°C	
Tie rod tightening torque (wrench 13)		30 Nm	22 lbft

NOTE - For different conditions please contact Sales Dept.

## Dimensional data

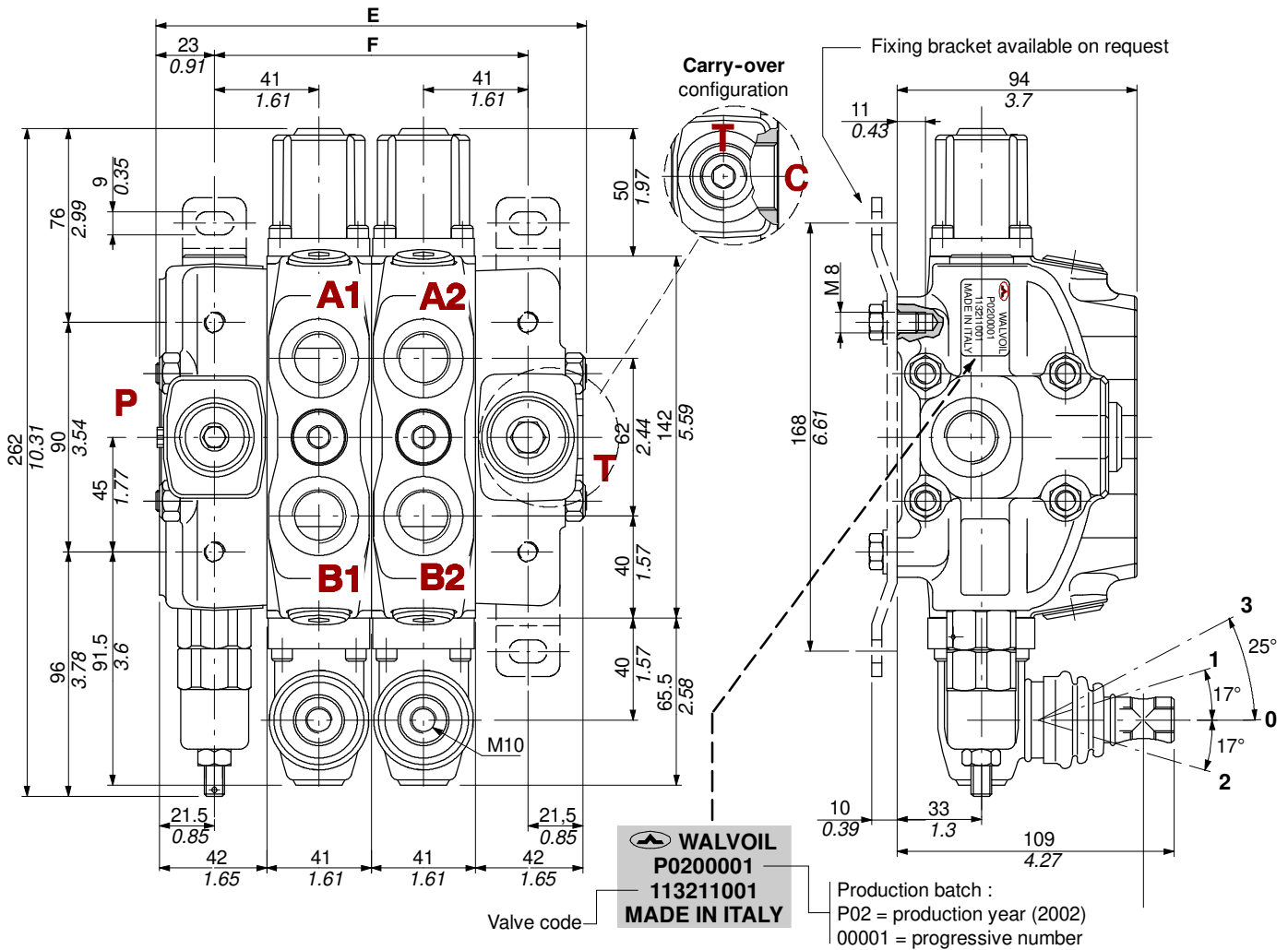

TYPE	E		F		Weight	
	mm	in	mm	in	kg	lb
SD8/1	128	5.04	82	3.23	7.2	15.9
SD8/2	169	6.65	123	4.84	10.5	23.1
SD8/3	210	8.27	164	6.46	13.8	30.4
SD8/4	251	9.88	205	8.07	17.1	37.7
SD8/5	292	11.5	246	9.69	20.1	44.3
SD8/6	333	13.11	287	11.3	23.4	51.6

TYPE	E		F		Weight	
	mm	in	mm	in	kg	lb
SD8/7	374	14.72	328	12.91	26.7	58.9
SD8/8	415	16.33	369	14.52	30	66.2
SD8/9	456	17.94	410	16.13	33.3	73.5
SD8/10	497	19.55	451	17.74	36.6	80.8
SD8/11	538	21.16	492	19.35	39.9	88.1
SD8/12	579	22.77	533	20.96	43.2	95.4

### Standard threads

PORTS	BSP (ISO 228/1)	UN-UNF (ISO 11926-1)	METRIC (ISO 6149-1)
Inlet P	G 1/2	7/8-14 (SAE 10)	M22x1.5
A and B ports	G 1/2	3/4-16 (SAE 8)	M22x1.5
Outlet T and carry-over C	G 3/4	7/8-14 (SAE 10)	M27x2
PILOT PORTS			
Hydraulic	G 1/4	9/16-18 (SAE 6)	G 1/4
Pneumatic	NPTF 1/8-27	NPTF 1/8-27	NPTF 1/8-27

## Hydraulic circuit

### Parallel

Standrad configuration with open centre and side inlet and outlet.

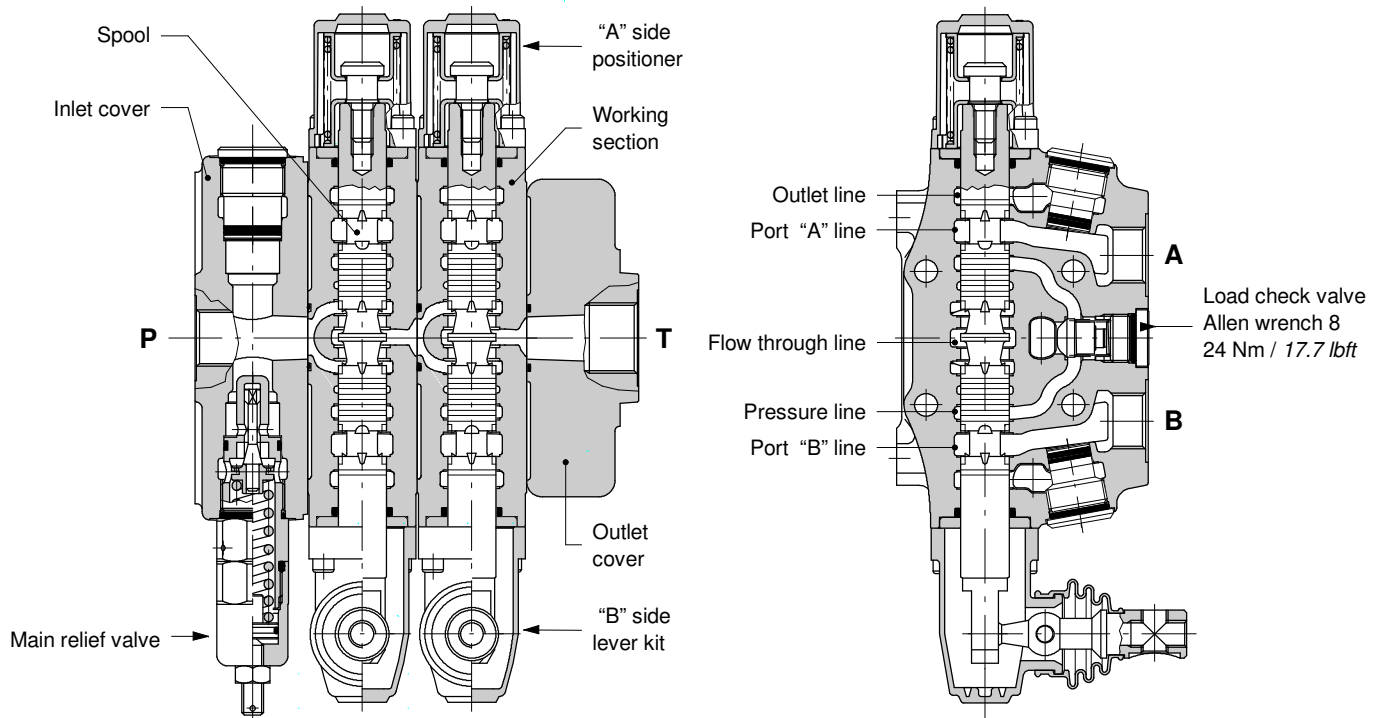

### Hydraulic circuit

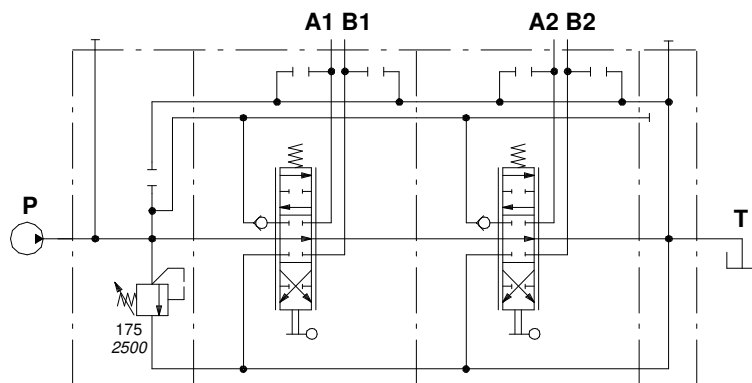

Description example:

SD8/2/AC(YG3-175)/18L/18L/RC

### Series-parallel (tandem) circuit

It needs a special working section kit.

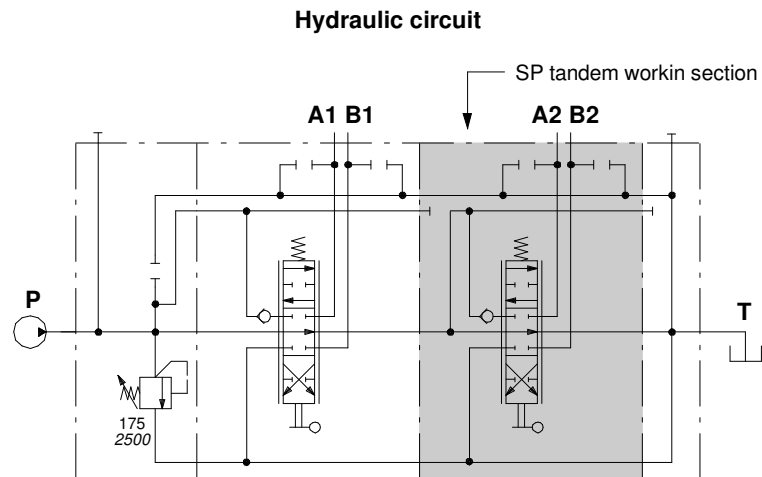

### Series circuit

It's obtained by mounting a 1S series spool (or 2S, see pages 22 and 23) on a standard parallel section. The next section must be a series-parallel (tandem) one.

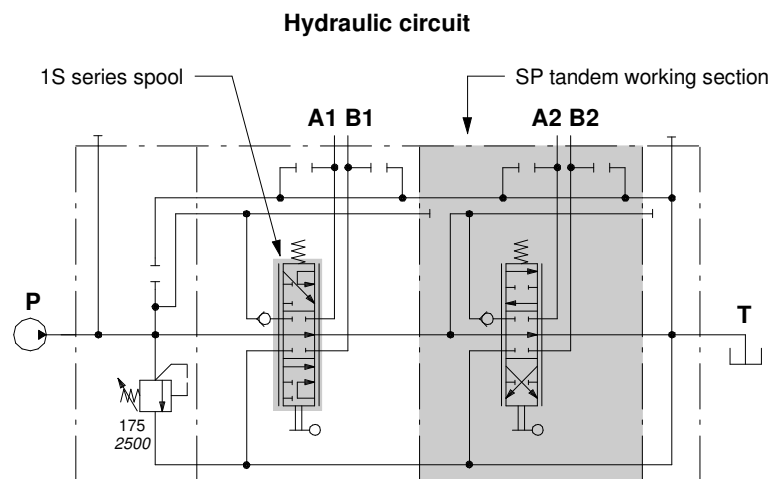

NOTA - The flows  $P \rightarrow A$  and  $P \rightarrow B$ , on the series spool, are reversed.

Hydraulic circuit

Directional valve with right inlet

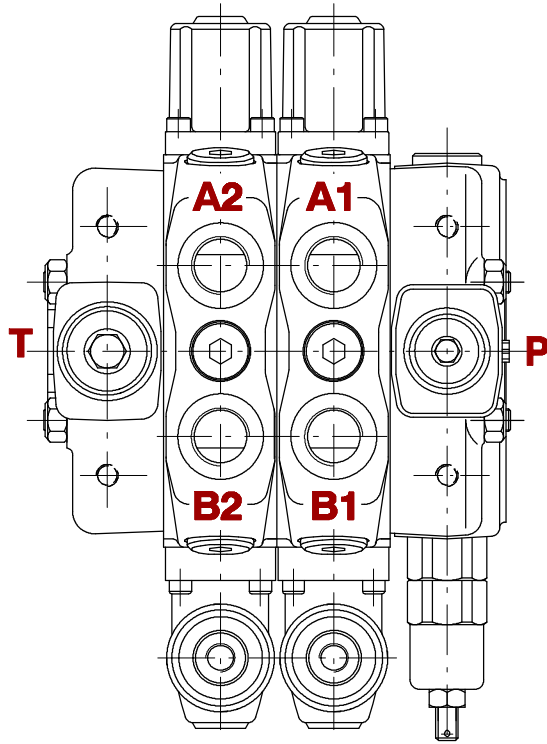

Hydraulic circuit



Description example:

SD8/2/BC(YG3-175)/18L/18L/RC

Performance data (pressure drop vs. flow)

Open centre

From side inlet to side outlet.

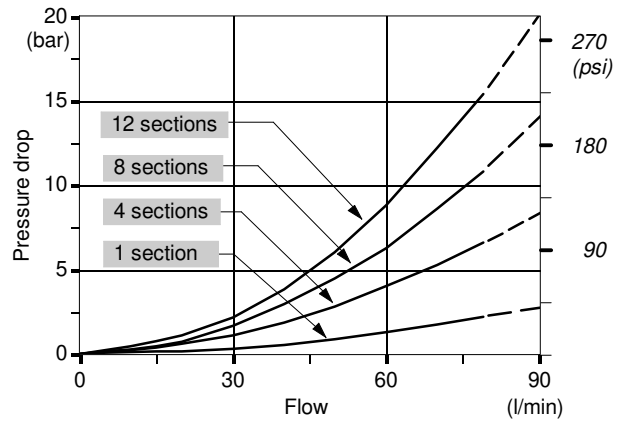
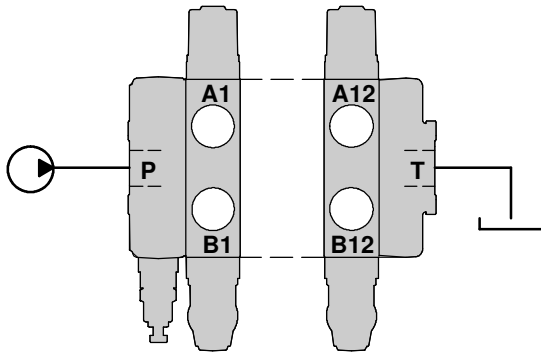

Inlet to work port

From side inlet to A port (spool in position 1) or B port (spool in position 2).

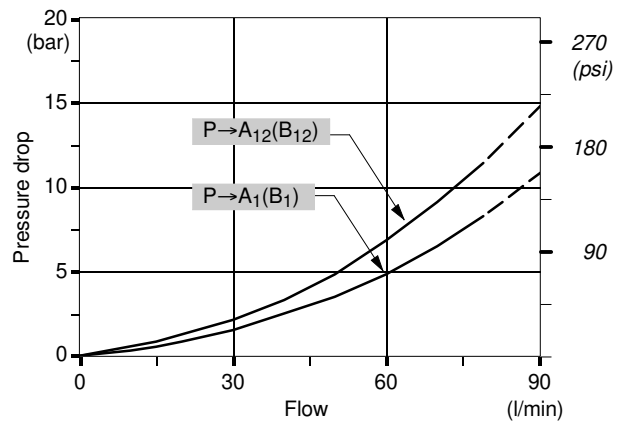
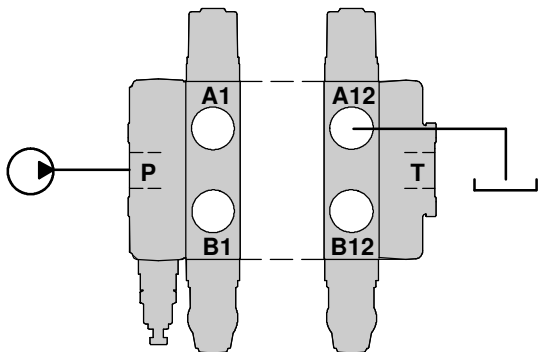

Work port to outlet

From A port (spool in position 2) or B port (spool in position 1) to side outlet.

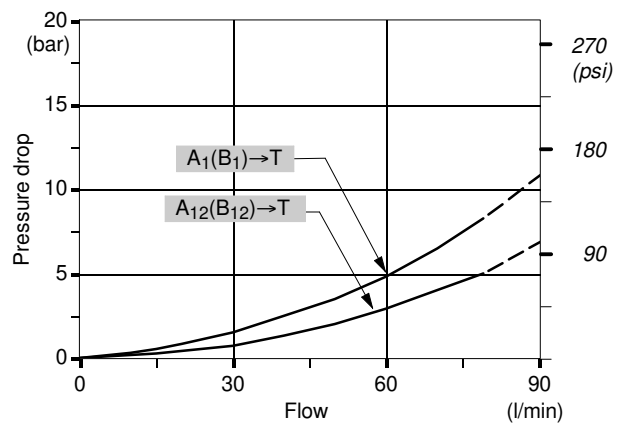
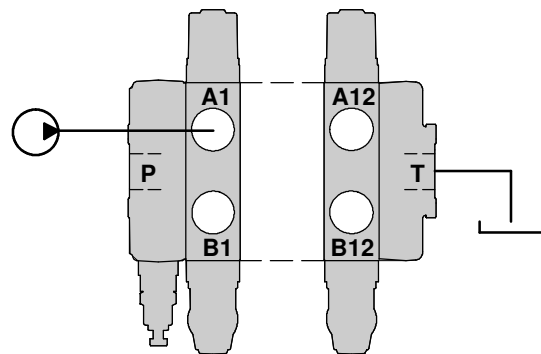

NOTE - Measured with spool type 1.

## Ordering codes

## Description example: standard configuration with side inlet and outlet

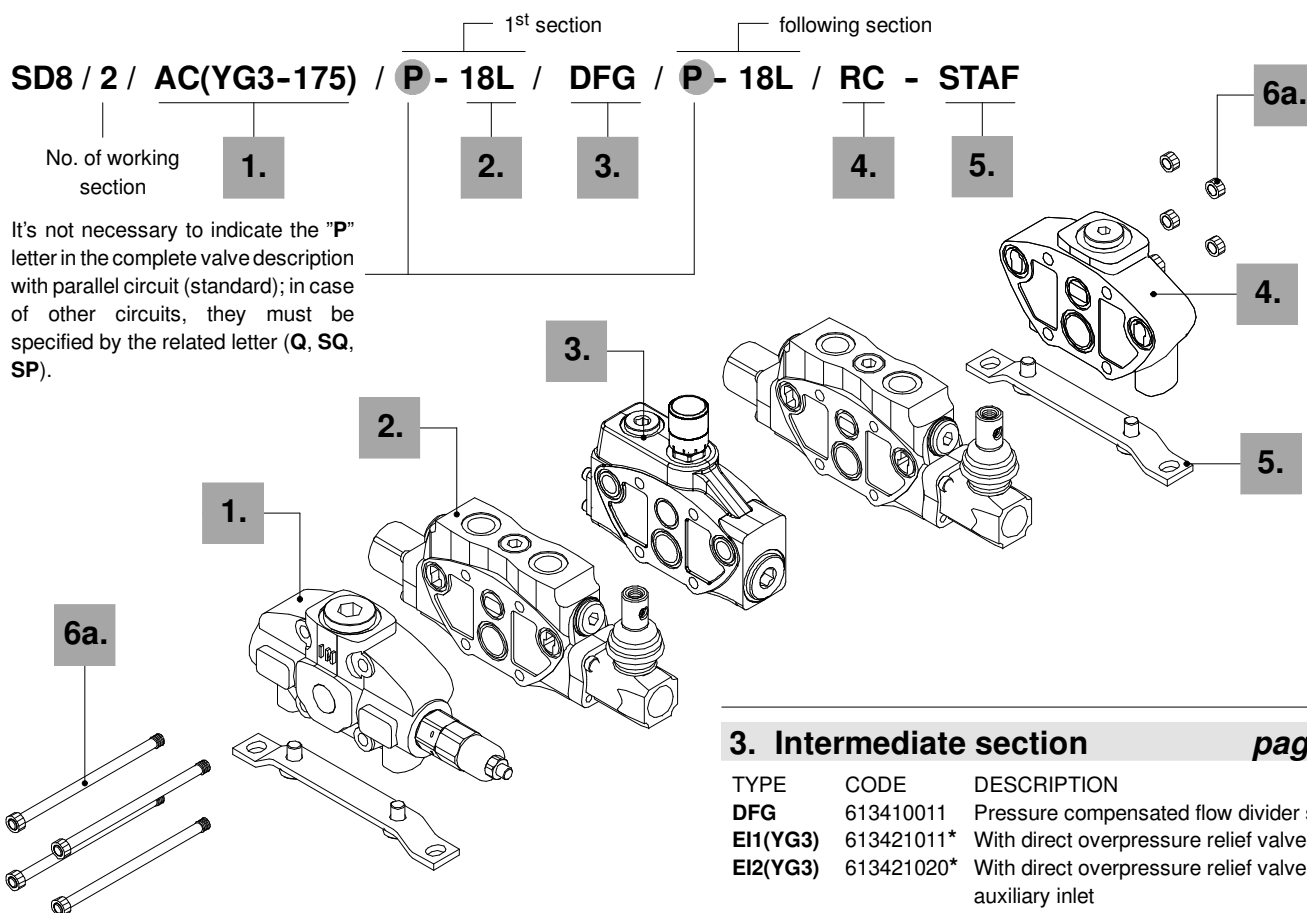

It's not necessary to indicate the "P" letter in the complete valve description with parallel circuit (standard); in case of other circuits, they must be specified by the related letter (Q, SQ, SP).

3. Intermediate section page 28

TYPE	CODE	DESCRIPTION
DFG	613410011	Pressure compensated flow divider section
EI1(YG3)	613421011*	With direct overpressure relief valve
EI2(YG3)	613421020*	With direct overpressure relief valve and auxiliary inlet

4. Complete outlet cover \* page 30

TYPE	CODE	DESCRIPTION
RC	613300110	Side outlet
RD	613300112	Upper outlet
RE	613300111	Upper outlet with side carry-over
RK	613300120	Upper outlet with closed centre

5. Fixing bracket page 70

TYPE	CODE	DESCRIPTION
STAF	5STA125190	Brackets with fixing screws

1. Complete inlet cover \* page 12

TYPE	CODE	DESCRIPTION
AC(YG3-175)	613201007	Side inlet with direct pressure relief valve
AC(XG-120)	613201019	Side inlet with pilot operated pressure relief valve
AC(SV)	613201020	Side inlet with valve blanking plug

For special configuration see page 17

2. Complete working section \* page 18

TYPE	CODE	DESCRIPTION
Q-18L	613151001	Parallel circuit, double acting spool with spring return, lever control
P-18L	613101001	As previous, prearranged for port valves
P-1S8L	613111001	As previous with series circuit spool
SP-18L	613121002	As previous with series-parallel (tandem) circuit

Always indicate the letter in the complete description of each single section, identifying the type of circuit (P, SP, Q or SQ).

## 6a. Assembling kit

CODE	DIRECTIONAL VALVE
5TIR108128	Tie rod kit for 1 section valve
5TIR108169	Tie rod kit for 2 sections valve
5TIR108210	Tie rod kit for 3 sections valve
5TIR108251	Tie rod kit for 4 sections valve
5TIR108292	Tie rod kit for 5 sections valve
5TIR108333	Tie rod kit for 6 sections valve
5TIR108374	Tie rod kit for 7 sections valve
5TIR108415	Tie rod kit for 8 sections valve
5TIR108456	Tie rod kit for 9 sections valve
5TIR108497	Tie rod kit for 10 sections valve
5TIR108538	Tie rod kit for 11 sections valve
5TIR108579	Tie rod kit for 12 sections valve

NOTE (\*) - Items are referred to **BSP** thread.

Description example: configuration with 2 side inlets and mid return manifold:

SD8 / 2 / AC(YG3-175) / P - 18L / CST / P - ED - 18L / BC(YG3-120) - STAF

1.

2.

7.

8.

9.

5.

CS1 collector needs standard assembling kit "6a".  
CST collector needs dedicated assembling kit "6b".

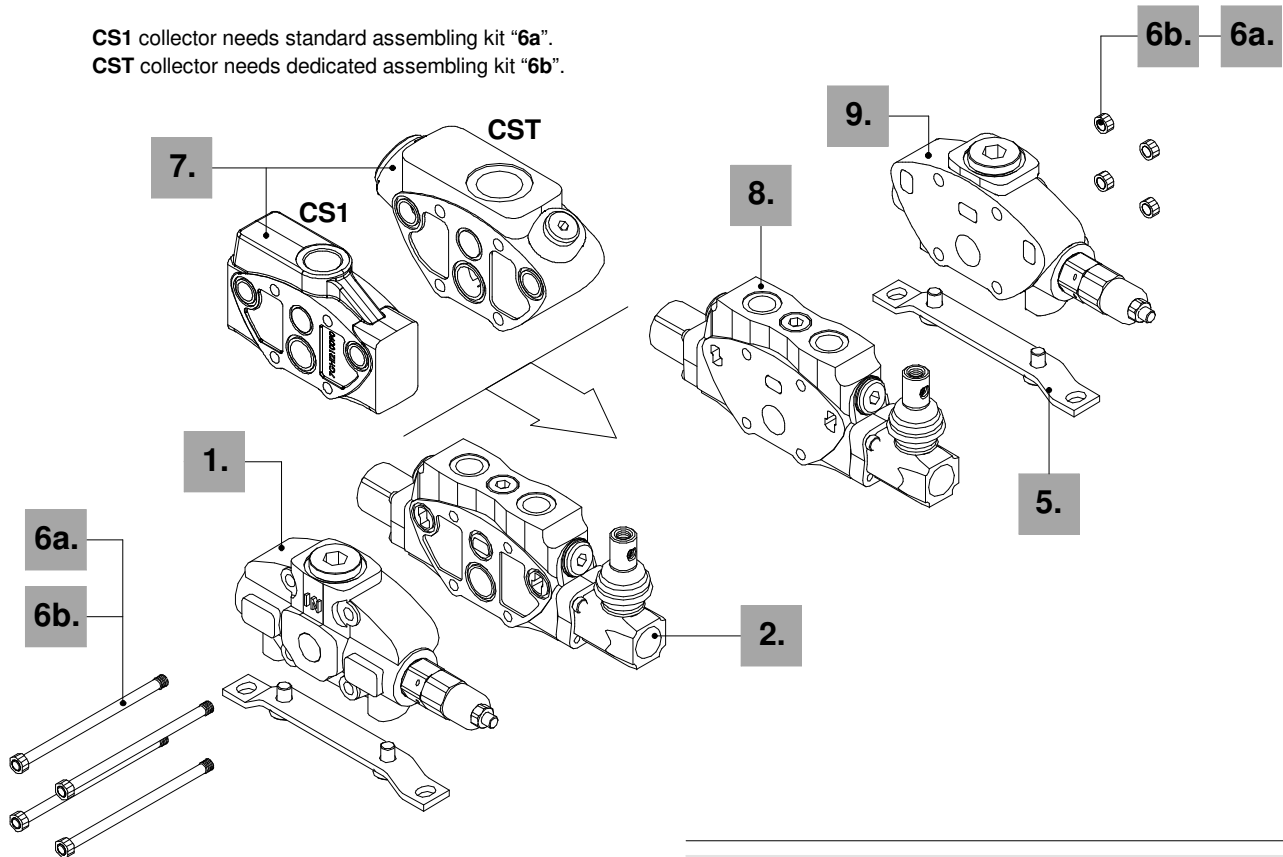

### 6b. Assembling kit for valve with CST

CODE	DIRECTIONAL VALVE (with CSMT)
5TIR108301	Tie rod kit for 4 sections valve (+ CST)
5TIR108342	Tie rod kit for 5 sections valve (+ CST)
5TIR108383	Tie rod kit for 6 sections valve (+ CST)
5TIR108424	Tie rod kit for 7 sections valve (+ CST)
5TIR108465	Tie rod kit for 8 sections valve (+ CST)
5TIR108506	Tie rod kit for 9 sections valve (+ CST)
5TIR108547	Tie rod kit for 10 sections valve (+ CST)

### 7. Return manifold

page 27

TYPE	CODE	DESCRIPTION
CST	613401400	Mid return manifold with G1 outlet port
CS1	613401010	Mid return manifold with G3/4 outlet port

### 8. Complete right inlet working section \*

TYPE	CODE	DESCRIPTION
Q-ED-18L	613151003	Parallel circuit, double acting spool with spring return, lever control
P-ED-18L	613101024	As previous, prearranged for port valves
P-ED-1S8L	613111002	As previous with series circuit spool
SP-ED-18L	613121003	As previous with series-parallel (tandem) circuit

### 9. Complete right inlet cover \*

TYPE	CODE	DESCRIPTION
BC(YG3-175)	613201009	Side inlet with direct pressure relief valve
BC(XG-120)	613201133	Side inlet with pilot operated pressure relief valve
BC(SV)	613201134	Side inlet with valve blanking plug

NOTE (\*) - Items are referred to **BSP** thread; sections and covers for right inlet are different from the standard (see ref. 1 e 2) because of different components assembling

Ordering codes

Description example:

FE SD8 / AC (YG3 - 175) EL - MAN14 - 12VDC \*

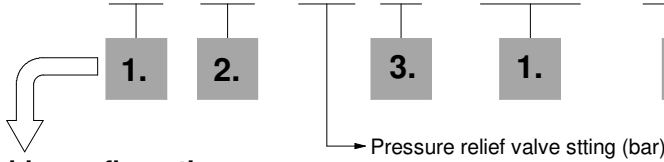

Available configurations

- AC: with side inlet, for left inlet (standard) directional valve
  - AD: with upper inlet, for left inlet (standard) directional valve
  - BC: with side inlet, for right inlet directional valve
  - BD: with upper inlet, for right inlet directional valve
- See page 13.

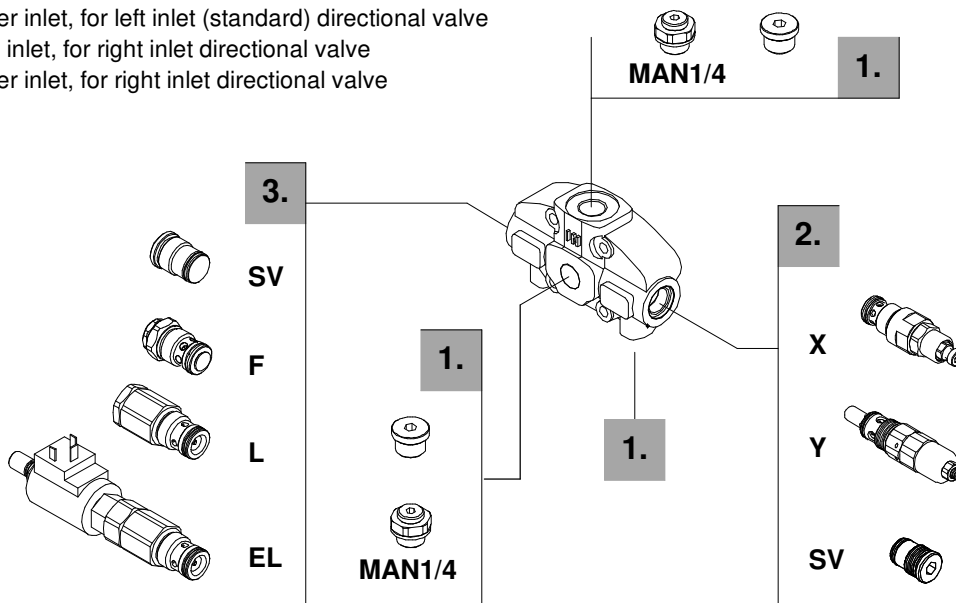

1. Inlet cover \* page 13

CODE	DESCRIPTION
3FIA108301 + 3XTAP727180	Standard
3FIA108301 + 5MAN625220	With pressure gauge port G1/8
3FIA108301 + 5MAN627240	With pressure gauge port G1/4

2. Inlet relief options page 14

TYPE	CODE	DESCRIPTION
<u>MP150/1 pilot operated pressure relief valve type X</u>		
(XG-125)	X006211120	Range 25 to 315 bar / 360 to 4600 psi standard setting 125 bar / 1800 psi
<u>VMD10/1 direct pressure relief valve type Y (standard)</u>		
(YG1-80)	3XCAR110212	Range 63 to 125 bar / 910 to 1800 psi standard setting 80 bar / 1160 psi
(YG2-125)	3XCAR110212	Range 100 to 160 bar / 1450 to 2300 psi standard setting 125 bar / 1800 psi
(YG3-175)	3XCAR110213	Range 125 to 250 bar / 1800 to 3600 psi standard setting 175 bar / 2500 psi
(YG4-220)	3XCAR110214	Range 200 to 315 bar / 2900 to 4600 psi standard setting 220 bar / 3200 psi

Standard setting is referred to 10 l/min flow.

SV XTAP526340 Relief valve blanking plug

3. Inlet valve options page 16

TYPE	CODE	DESCRIPTION
F	3XCAR410200	Inlet anti-cavitation valve
L	XCAR410311	Hydraulic pilot unloader valve (FC1.5)
EL	YCAR410305	12 VDC electromagnetic controlled unloader valve
	YCAR410320	24 VDC electromagnetic controlled unloader valve
SV	XTAP526340	Relief valve blanking plug

NOTE (\*) - Items are referred to **BSP** thread.

Inlet cover body and hydraulic circuit

For left inlet directional valve

Type AC

Allen wrench 8  
24 Nm / 17.7 lbf

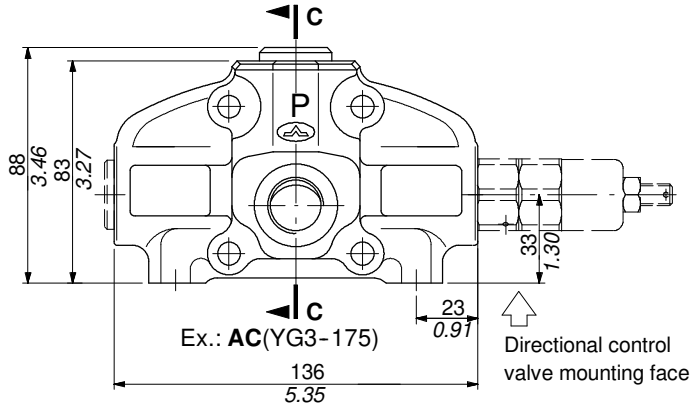
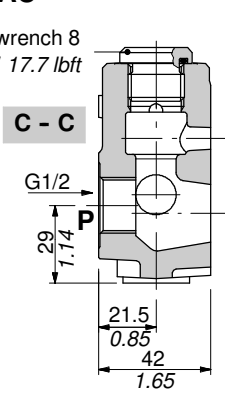

Hydraulic circuit

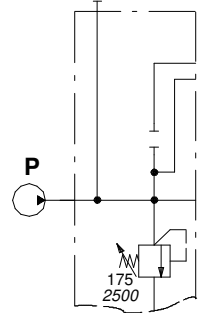

Type AD

Allen wrench 12  
24 Nm / 17.7 lbf

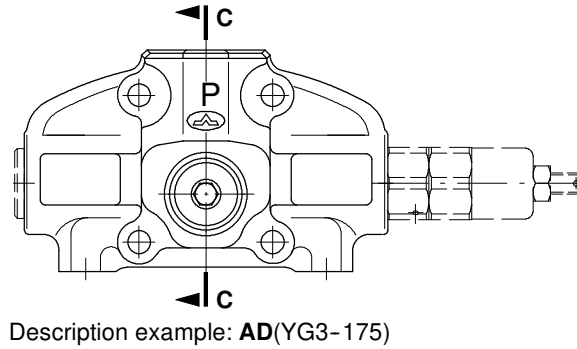
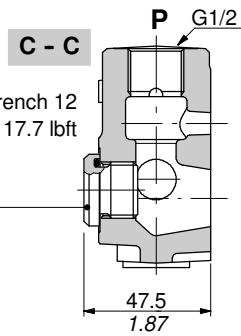

Hydraulic circuit

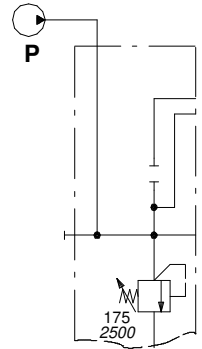

For right inlet directional valve

Type BC

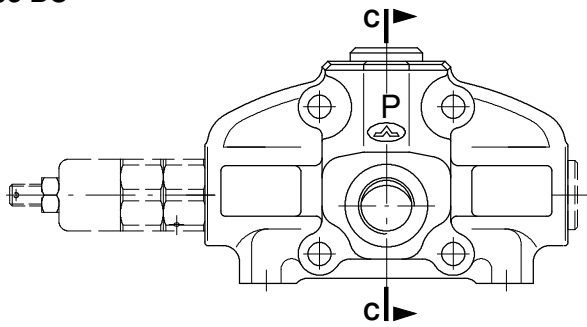

Hydraulic circuit

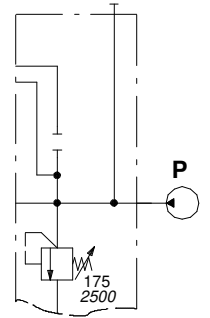

Type BD

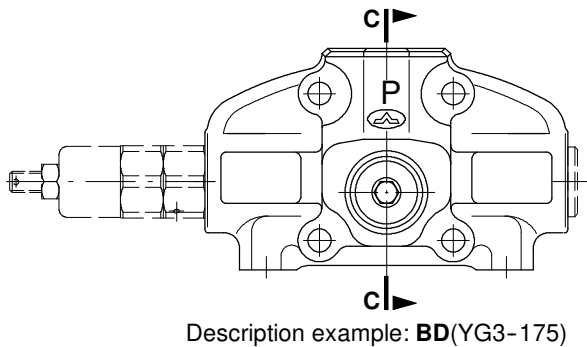

Hydraulic circuit

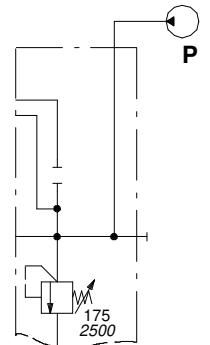

Inlet relief options

Direct overpressure relief valve

VMD10 ( Y G 3 - 175 )

- Pressure setting in bar (for standard value see page 14)
- Adjustable spring type (1, 2, 3, 4).
- Adjustment type (G, H)

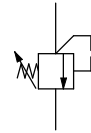

Adjustment type

G: with screw

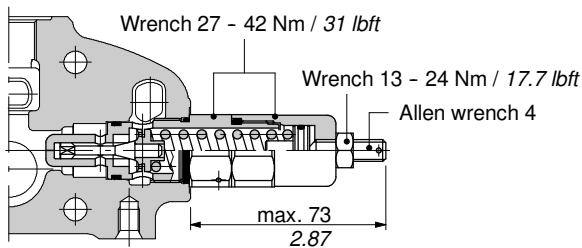

H: valve set and locked

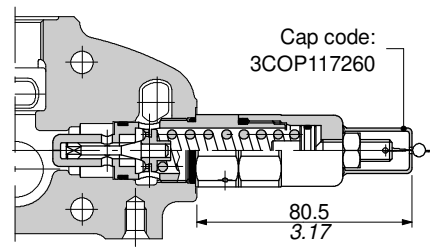

Performance data

Spring nr.1 (white band)

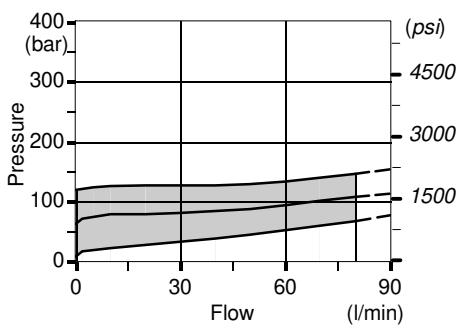

Spring nr. 2 (green band)

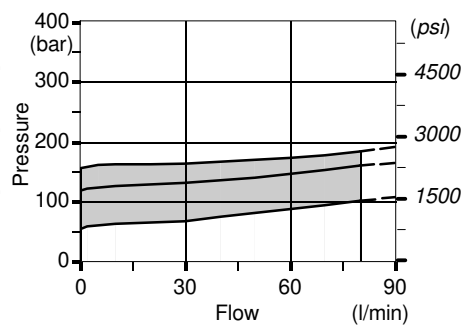

Spring nr. 3 (blue band)

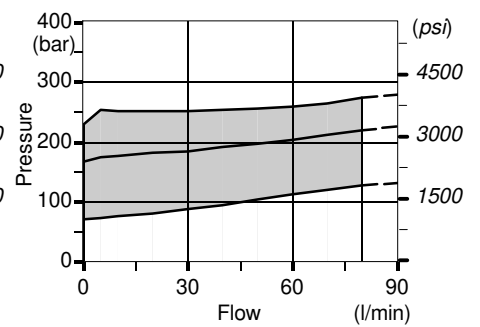

Spring nr. 4 (red band)

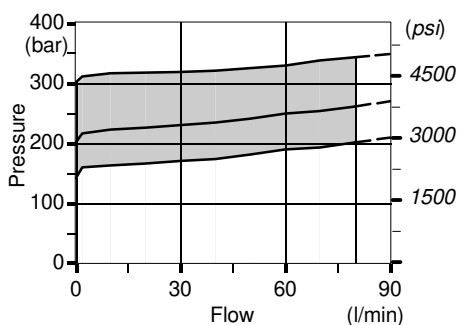

Time response

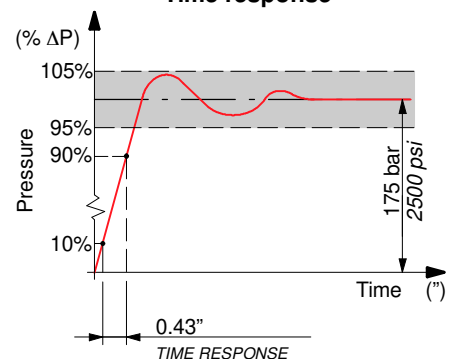

Inlet relief options

Pilot operated pressure relief valve

VMP150 ( X G - 120 )

Pressure setting in bar (for standard value see page 14)  
 Adjustment type (G, Z)

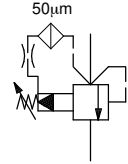

Adjustment type

G: with screw

Z: with nylon tamper proof cap

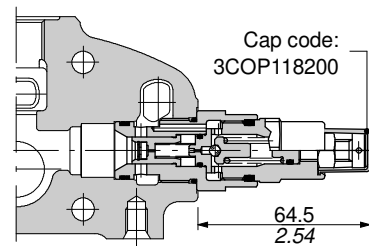
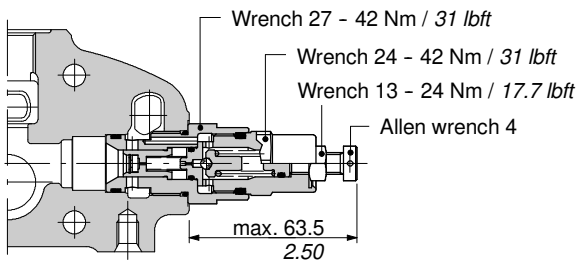

Performance data

Spring nr. 3 (blue band)

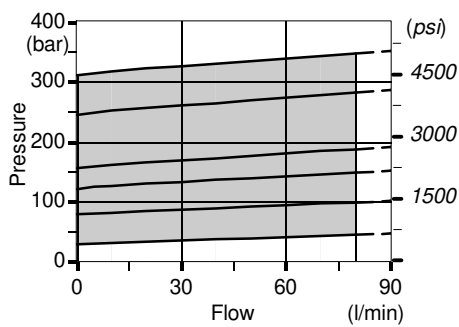

Time response

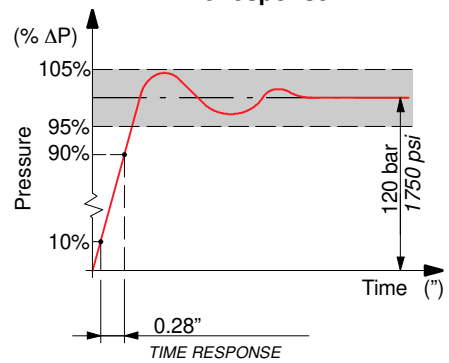

SV: relief valve blanking plug

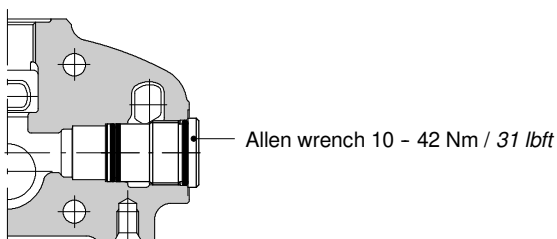

**Inlet valve options**

**Anti-cavitation valve F**

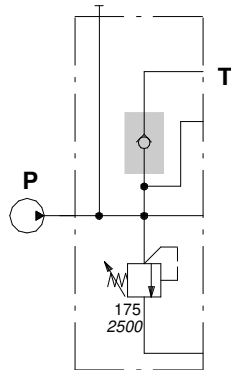
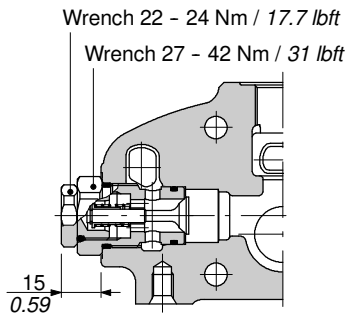

Ex.: AC(YG3-175)F

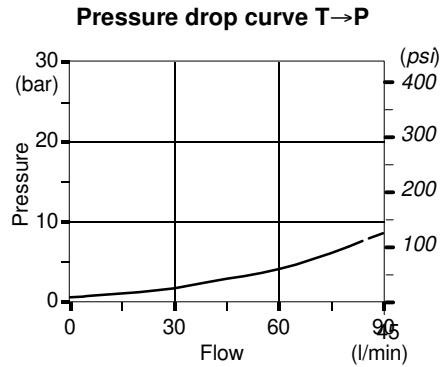

**Unloader valves**

**Hydraulic pilot operated type L**

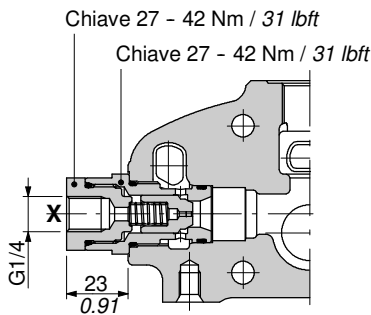

**Electro-hydraulic pilot operated type EL**

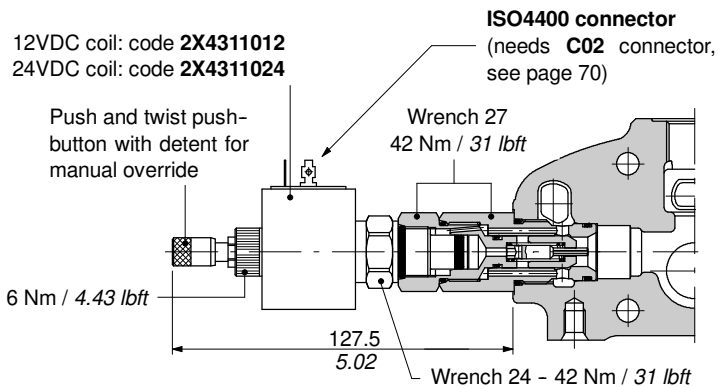

**Operating features**

Internal leakage ..... : 10 cm<sup>3</sup>/min at 100 bar  
 0.61 in<sup>3</sup>/min at 1450 psi

**Solenoid operating features**

Nominal voltage tolerance ..... : ±10%  
 Power rating ..... : 19 W  
 Nominal current ..... : 1.58A - 12 VDC  
 : 0.81 A - 24VDC  
 Coil insulation ..... : Class F  
 Weather protection ..... : IP65  
 Duty cycle ..... : 100%

**Hydraulic circuit**

**With valve L**

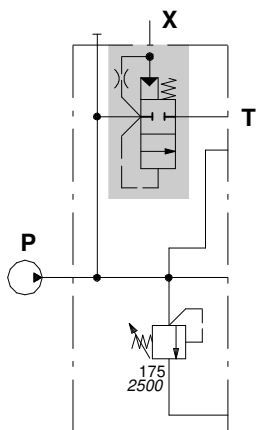

Ex.:AC(YG3-175)L

**With solenoid valve EL**

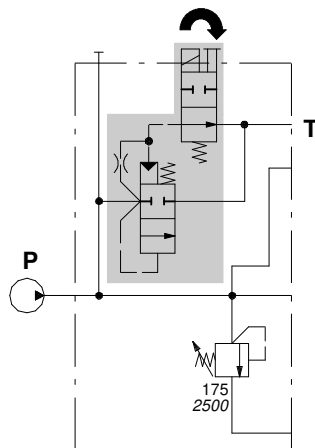

Ex.:AC(YG3-175)EL-12VDC

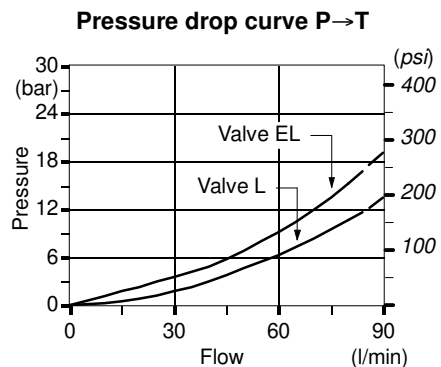

**R2 commutator configuration**

Manual rotary Backhoe clamp device.

Normally mounted on the lever side, into the main relief valve cavity, properly modified. Main relief valve available in the opposite side.

Available for left inlet (standard) and right inlet valve.

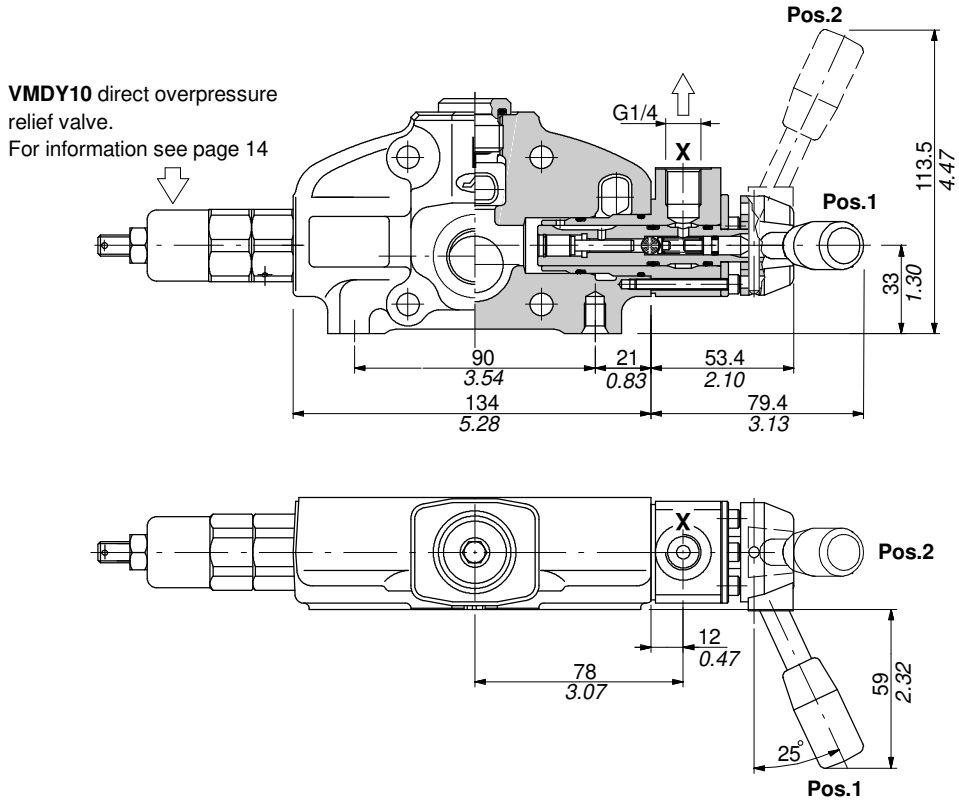

**Hydraulic circuit and ordering codes**

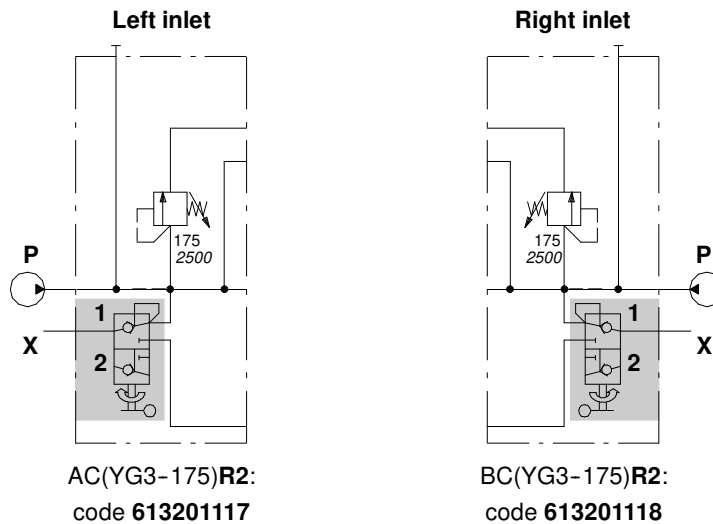

Ordering codes

Description example:

EL SD8 / P - 1 8 L . P 1 (G3 - 100) \*

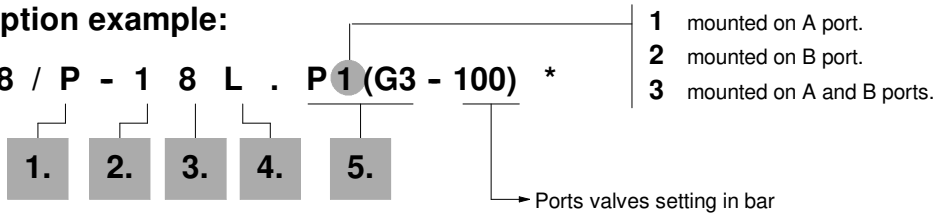

EL SD8 / P - 1M 8IM

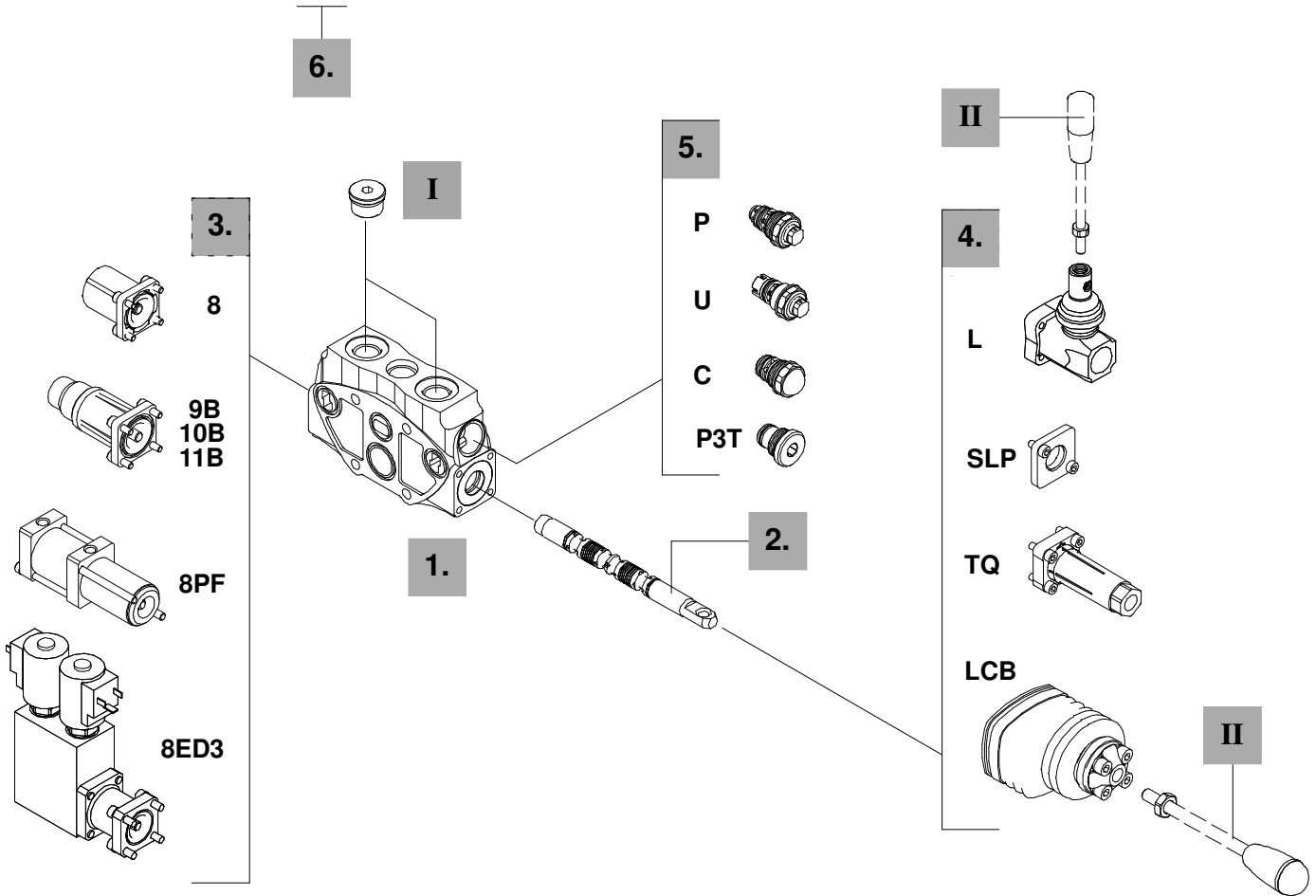

1. Working section kits \* page 20

TYPE	CODE	DESCRIPTION
Q	5EL1083010	Without ports valve prearrangement, with parallel circuit
P	5EL1083000	With ports valve prearrangement, with parallel circuit
SQ	5EL3083020	Without ports valve prearrangement, with series-parallel (tandem) circuit
SP	5EL3083010	With ports valve prearrangement, with series-parallel (tandem) circuit

Include boby, seals, rings and load check valve.

NOTE (\*) - Items are referred to **BSP** thread.

2. Spools page 21

TYPE	CODE	DESCRIPTION
1	3CU2310100	Double acting, 3 positions, with A and B closed in neutral position
1A	3CU2321100	Double acting, 3 positions, with A open to tank in neutral position
1B	3CU2322100	Double acting, 3 positions, with B open to tank in neutral position
1S	3CU2311102	Double acting, 3 positions, with A and B closed in neutral position, for series
1CSG	3CU2310250	As type 1 with increased sensitivity, suggested for flow up to 70 l/min
1M	3CU2310420	As type 1 with increased sensitivity, suggested for flow higher than 70 l/min

..... follow

**2. Spools** **page 21**

TYPE	CODE	DESCRIPTION
2	3CU2325100	Double acting, 3 positions, with A and B open to tank in neutral position
2H	3CU2325225	Double acting, 3 positions, with A and B partially open to tank in neutral position
2S	3CU2327100	Double acting, 3 positions, with A and B open to tank in neutral position, for series
3	3CU2331110	Single acting on A, 3 positions, B plugged; requires G1/2 plug (see part I)
4	3CU2335100	Single acting on B, 3 positions, A plugged; requires G1/2 plug (see part I)
<u>Special spools for particular positioner kits</u> ..... page 25		
5B	3CU2343100	Double acting, 4 positions, float in position 3 with spool out
8F	3CU2361100	Double acting, 3 positions, with regenerative in position 1

**3. "A" side spool positioners** **page 48**

TYPE	CODE	DESCRIPTION
7FT	5V07208100	With friction and neutral position sensor
8	5V08108010	With spring return in neutral position
8D	5V08108202	As type 8 and pin with M8 female thread for dual control
8D1	5V08108210	As type 8 and pin with $\varnothing 8$ mm / 0.31 in radial hole
8D2	5V08108220	As type 8 and pin with M8 male thread for dual control
8TL	5V08108310	As type 8 and pin control with flexible cable
19	5V19108000	2 positions, with spring return in neutral position from position 1
20	5V19108000	2 positions, with spring return in neutral position from position 2
8IJ1	5V08108871*	With external hydraulic pilot for return from position 1 to neutral
8IJ2	5V08108861*	With external hydraulic pilot for return from position 2 to neutral
8IJ3	5V08108851*	With external hydraulic pilot for return from positions 1 and 2 to neutral
8MHE3(NC)	5V08108541	With spring return in neutral position and spool positioning ON/OFF electric signal circuit normally closed
8MHE3(NO)	5V08108540	As previous, with circuit normally open
9B	5V09108040	With detent in position 1 and spring return in neutral position
10B	5V10108040	With detent in position 2 and spring return in neutral position
11B	5V11108040	With detent in position 1 and 2, spring return in neutral position
11	5V11108000	With detent in position 1, neutral and 2
15	5V15108000	2 positions, detent in positions 1 and neutral
8EP3	5V08108735	ON/OFF 12 VDC electro-pneumatic kit
	5V08108740	ON/OFF 24 VDC electro-pneumatic kit
8ED3	5V08108360	ON/OFF 12 VDC electro-hydraulic kit
	5V08108361	ON/OFF 24 VDC electro-hydraulic kit
8PF	5V08108705	Proportional pneumatic kit
8MG3(NO)	5V08105660	With spring return in neutral position and operation with microswitch in pos. 1 and 2
..... follow		

**3. "A" side spool positioners**

TYPE	CODE	DESCRIPTION
<u>Particular positioner kits for special spools</u> ..... page 25		
8CR	5V08108022.....	3 positions with spring return in neutral and reduced spool stroke: <b>for spool 8F</b>
13C	5V13208020	4 positions with spring return in neutral position and detent in pos.3: <b>for spool 5B</b>

**4. "B" side options** **page 57**

TYPE	CODE	DESCRIPTION
L	5LEV108000	Standard lever box
LF3	5LEV108710	Lever box with adjustable flow limiters
LB	5LEV308000	Steel lever box
SLP	5COP108000	Without lever box, with dust-proof plate
SLCY	5COP208060	Without lever box, with endcap.
TQ	5TEL108110	Flexible cable connection; for CD cables
LCB	5CLO208000	Joystick lever for 2 sections operation

**5. Port relief valves** **page 64**

TYPE	CODE	DESCRIPTION
<u>Anti-shock valve</u>		
PR(G1-30)	XCAR208110	Range 15 to 35 bar / 218 to 508 psi standard setting 30 bar / 435 psi
PM(G1-50)	XCAR208109	Range 35 to 70 bar / 508 to 1010 psi standard setting 50 bar / 725 psi
P(G3-100)	3XCAR208113	Range 63 to 220 bar / 900 to 3200 psi standard setting 100 bar / 1450 psi
P(G4-200)	3XCAR208114	Range 180 to 350 bar / 2600 to 5050 psi standard setting 200 bar / 2900 psi
<u>Anti-shock and anti-cavitation valve</u>		
U(G2-63)	XCAR308112	Range 63 to 125 bar / 900 to 1800 psi standard setting 63 bar / 900 psi
U(G3-100)	XCAR308115	Range 100 to 250 bar / 1450 to 3600 psi standard setting 100 bar / 1450 psi
U(G4-200)	XCAR308114	Range 200 to 315 bar / 2900 to 4600 psi standard setting 200 bar / 2900 psi
Standard setting is referred to 10 l/min flow.		
C	XCAR408110	Anti-cavitation
DST	3XTAP624180	A and B ports valve blanking plugs with connection to tank
P3T	3XTAP524290	A and B ports valve blanking plugs

**6. Complete controls \*** **page 60**

Proportional hydraulic and ON/OFF electric control kits.

**I "A" and "B" ports plug \***

TYPE	CODE	DESCRIPTION
G 1/2	3XTAP727180	Plug for single acting spool

**II Optional handlevers**

TYPE	CODE	DESCRIPTION
AL01/M10x200	170012020	For L lever box L= 200 mm/7.87in
AL08/M12x200	170013120	For LCB joystick L=200 mm/7.87in

NOTE (\*) - Items are referred to **BSP** thread.

**Working section kit and hydraulic circuit**

They are available with parallel or tandem circuit, with or without ports relief valves prearrangement.

**Without port valves prearrangement type Q**

Parallel circuit

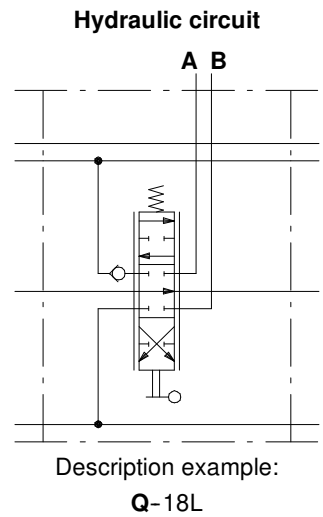
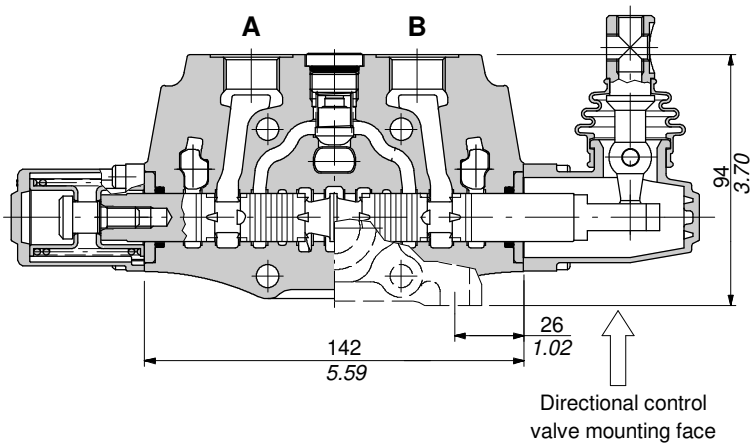

**With port valves prearrangement type P**

Parallel circuit

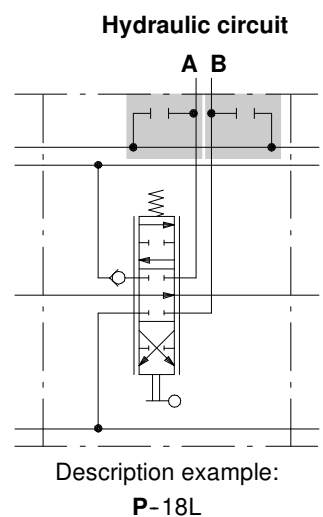
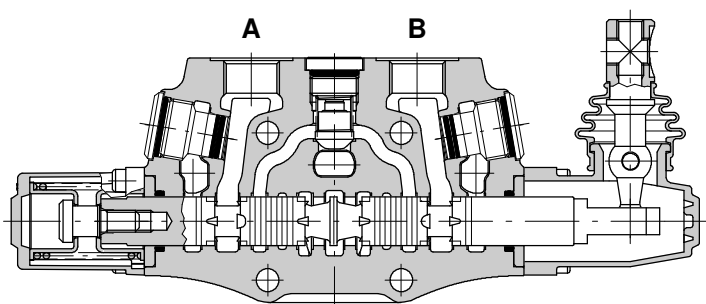

Type 1

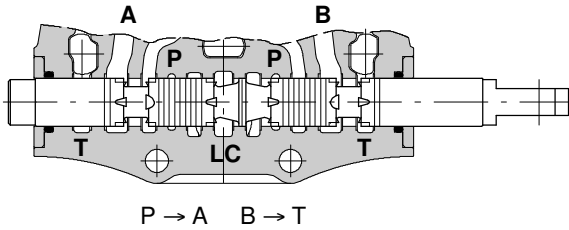

stroke + 7 mm  
+ 0.28 in

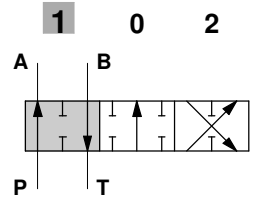

P → A B → T

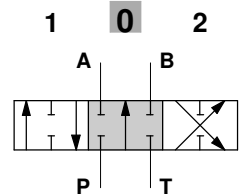
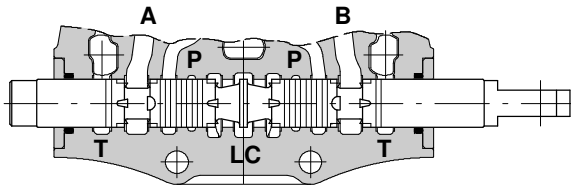

P-A-B-T closed, with flow through line (LC) open

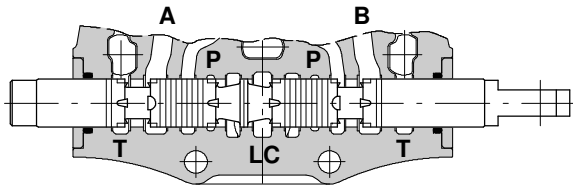

stroke - 7 mm  
- 0.28 in

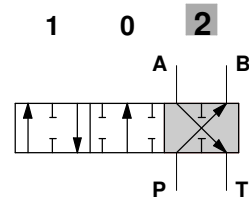

P → B A → T

Performance data

Spool metering P → A(B)

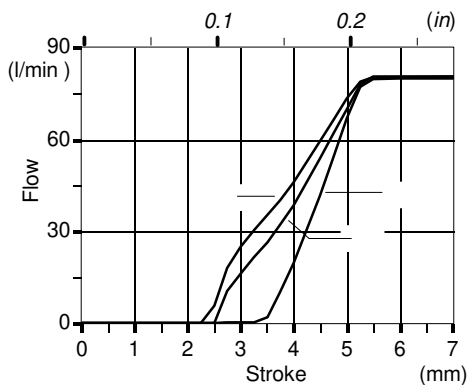

Q<sub>in</sub> = 80 l/min  
 P<sub>(on ports)</sub> = 63bar / 900 psi  
 P<sub>(on ports)</sub> = 100bar / 1450 psi  
 P<sub>(on ports)</sub> = 250bar / 3600 psi

Spool metering A(B) → T

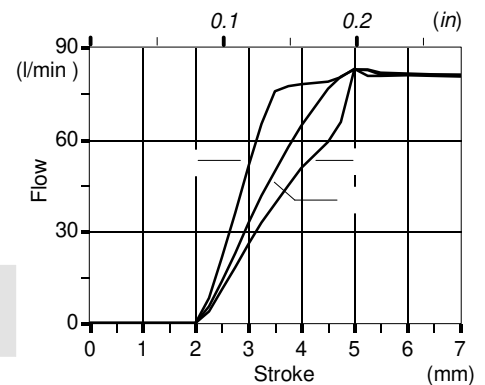

Spools

Type 1A

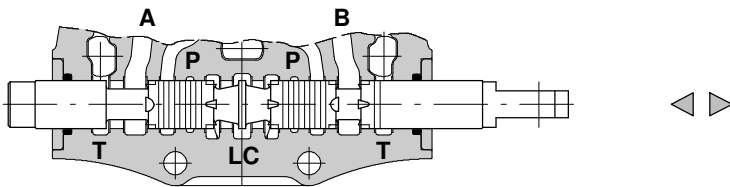

P-B closed, A→T, with flow through line (LC) open

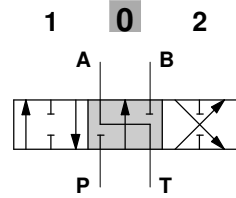

Type 1B

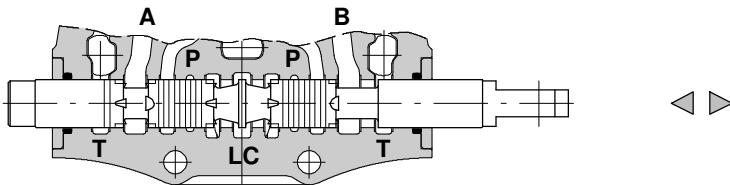

P-A closed, B→T, with flow through line (LC) open

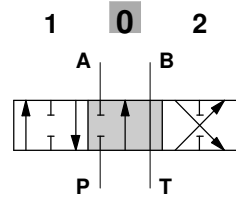

Type 1S

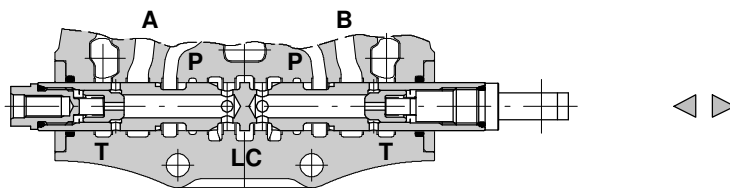

P-A-B-T closed, with flow through line (LC) open

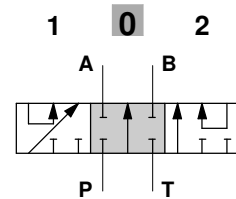

Spool metering

$Q_{in} = 80 \text{ l/min} / P_{(on ports)} = 250 \text{ bar} - 3600 \text{ psi}$   
 0.1 0.2 (in)

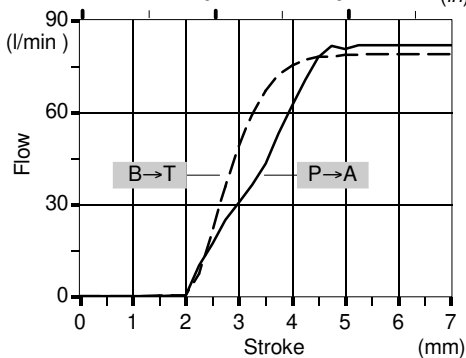

Pressure drop on series connection

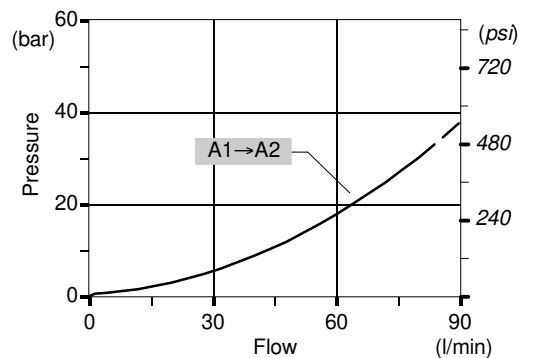

Type 2

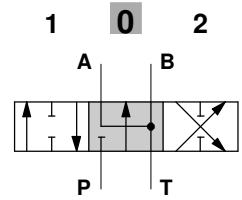
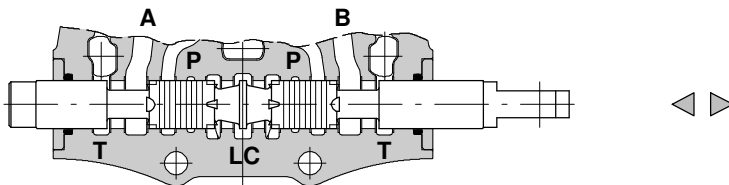

P closed, A-B→T, with flow through line (LC) open

Type 2H

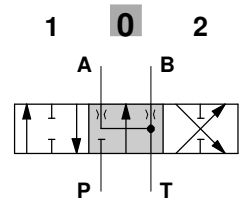
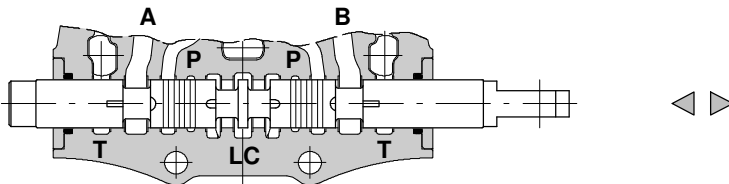

P closed, A-B partially to tank,  
with flow through line (LC) open

Type 2S

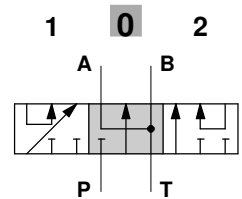
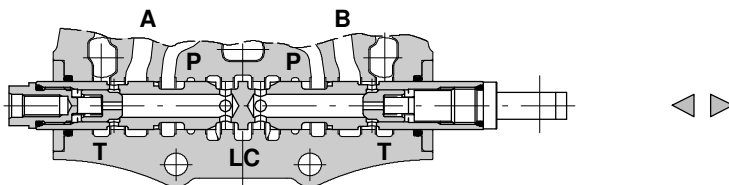

P closed, A-B→T, with flow through line (LC) open

Spools

Type 3

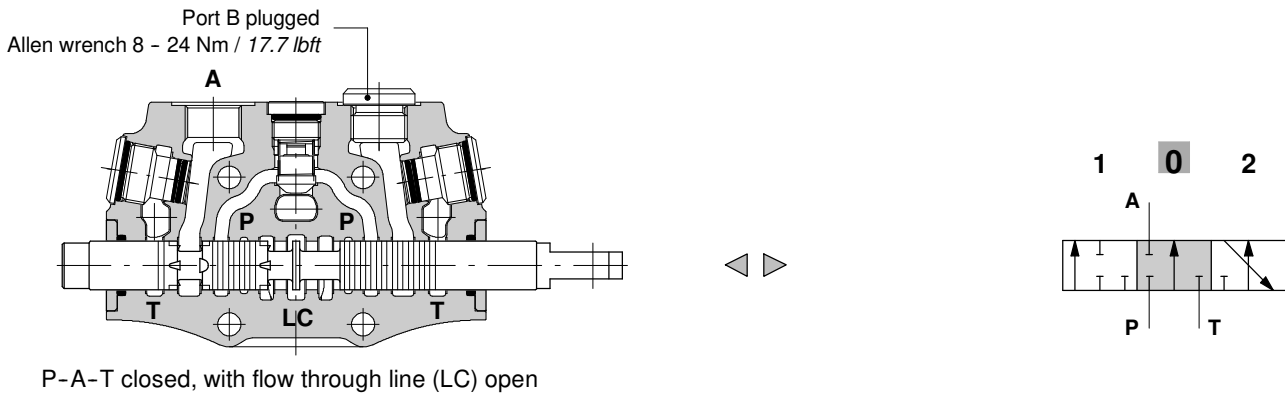

Type 4

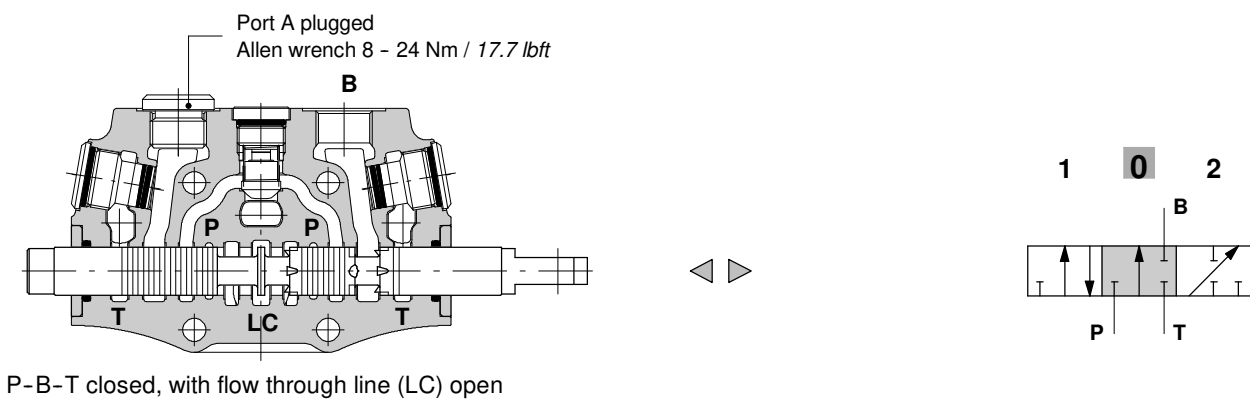

Type 5B

It needs special body with extra machining type **P-5** code **5EL108320A**. It must be coupled only with spool positioner **13C**.

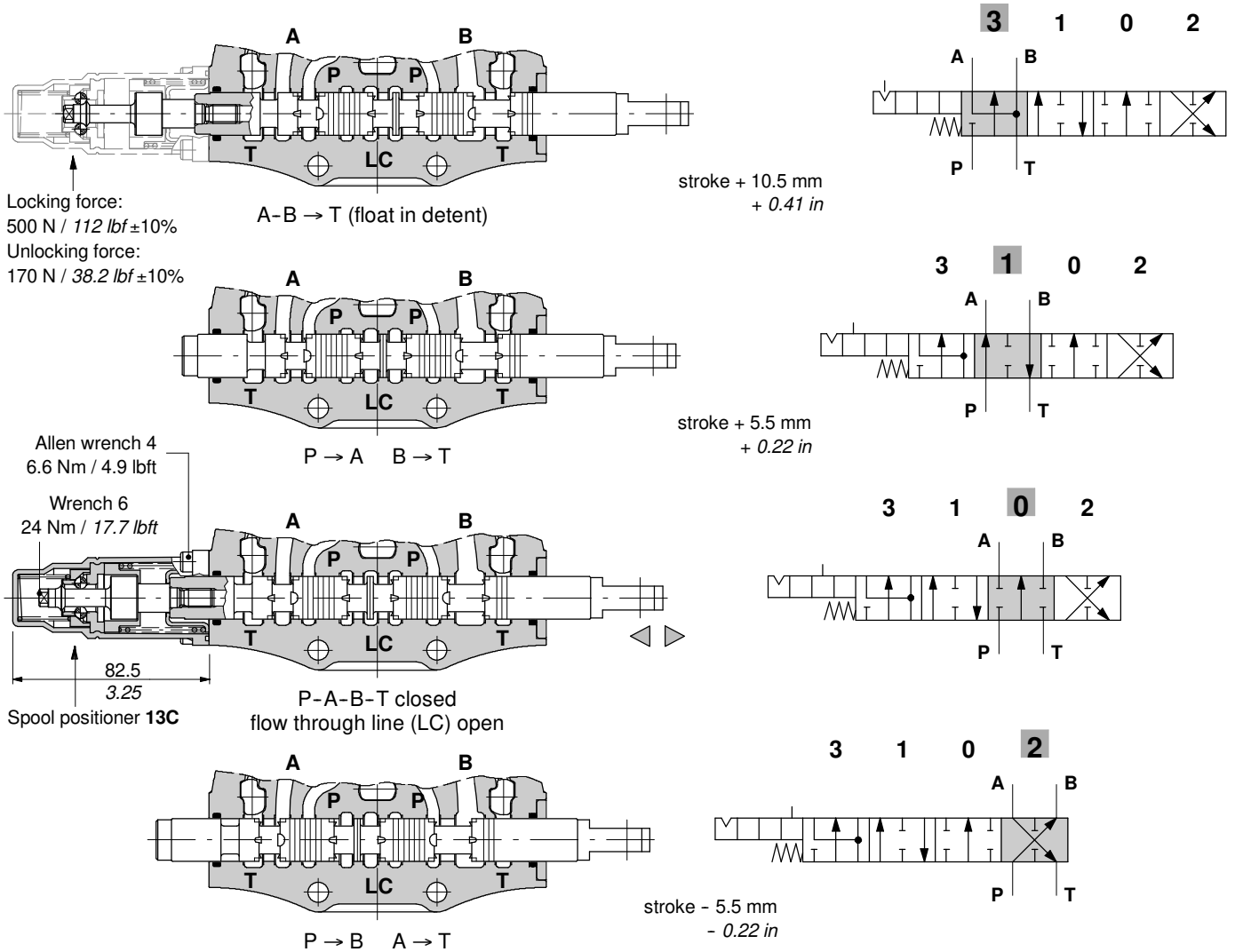

Performance data

Spool metering

$Q_{in} = 80 \text{ l/min} / P_{(on ports)} = 100 \text{ bar} - 1450 \text{ psi}$

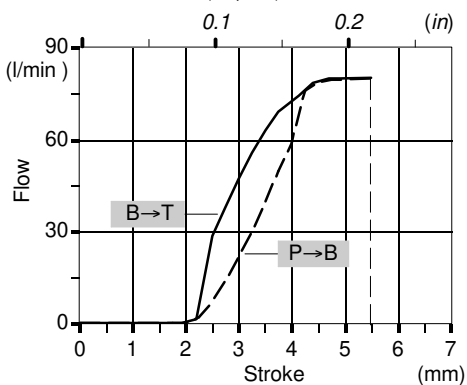

Pressure drop in position 3

(last section)

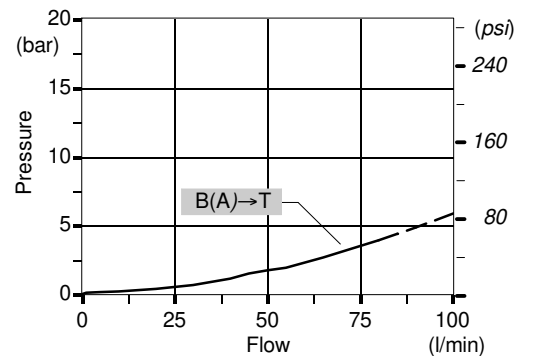

Spools

Type 8F

It must be coupled only with reduced stroke spool positioner 8CR.

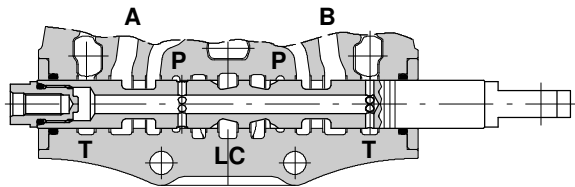

P+B → A (regenerative)

stroke + 6 mm  
+ 0.24 in

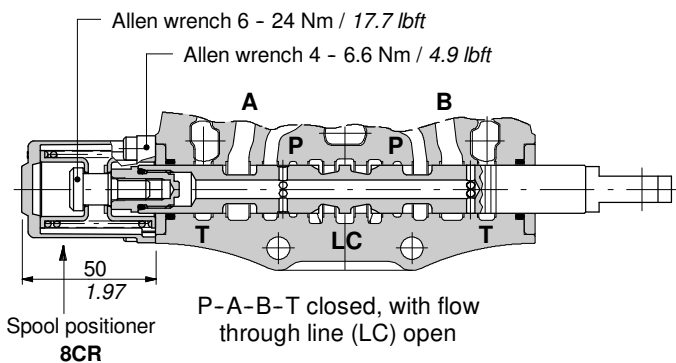
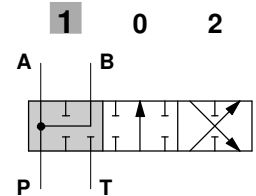

P-A-B-T closed, with flow through line (LC) open

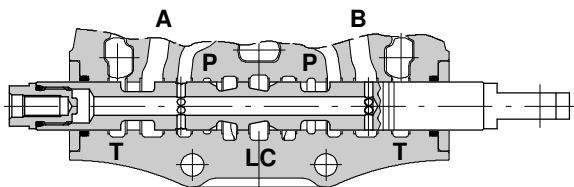
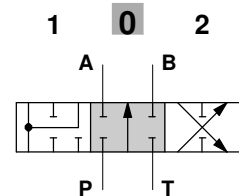

P → B A → T

stroke + 6 mm  
+ 0.24 in

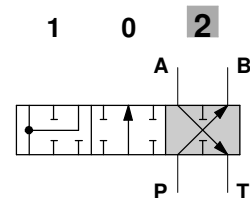

Performance data

Spool metering

Q<sub>in</sub> = 80 l/min / P<sub>(on ports)</sub> = 100 bar - 1450 psi

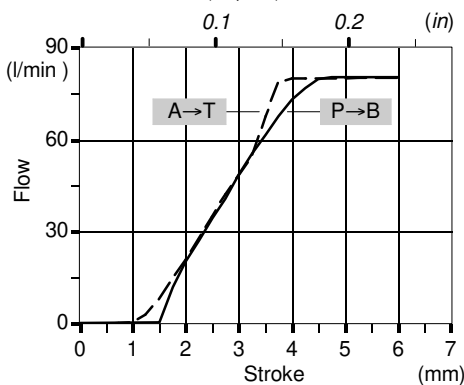

Q<sub>in</sub> = 80 l/min

- P<sub>(on ports)</sub> = 63bar / 900 psi
- P<sub>(on ports)</sub> = 100bar / 1450 psi
- P<sub>(on ports)</sub> = 250bar / 3600 psi

Pressure drop in positions 1 and 2  
(on 1<sup>st</sup> section)

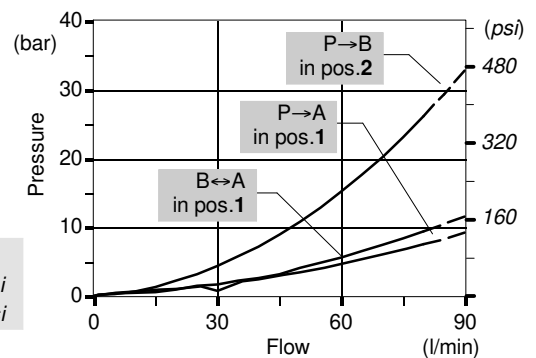

CS mid return manifold sections

Mid return manifolds for directional valve with left and right inlet both; they allow 2 independent circuits with common outlet.

Type CST

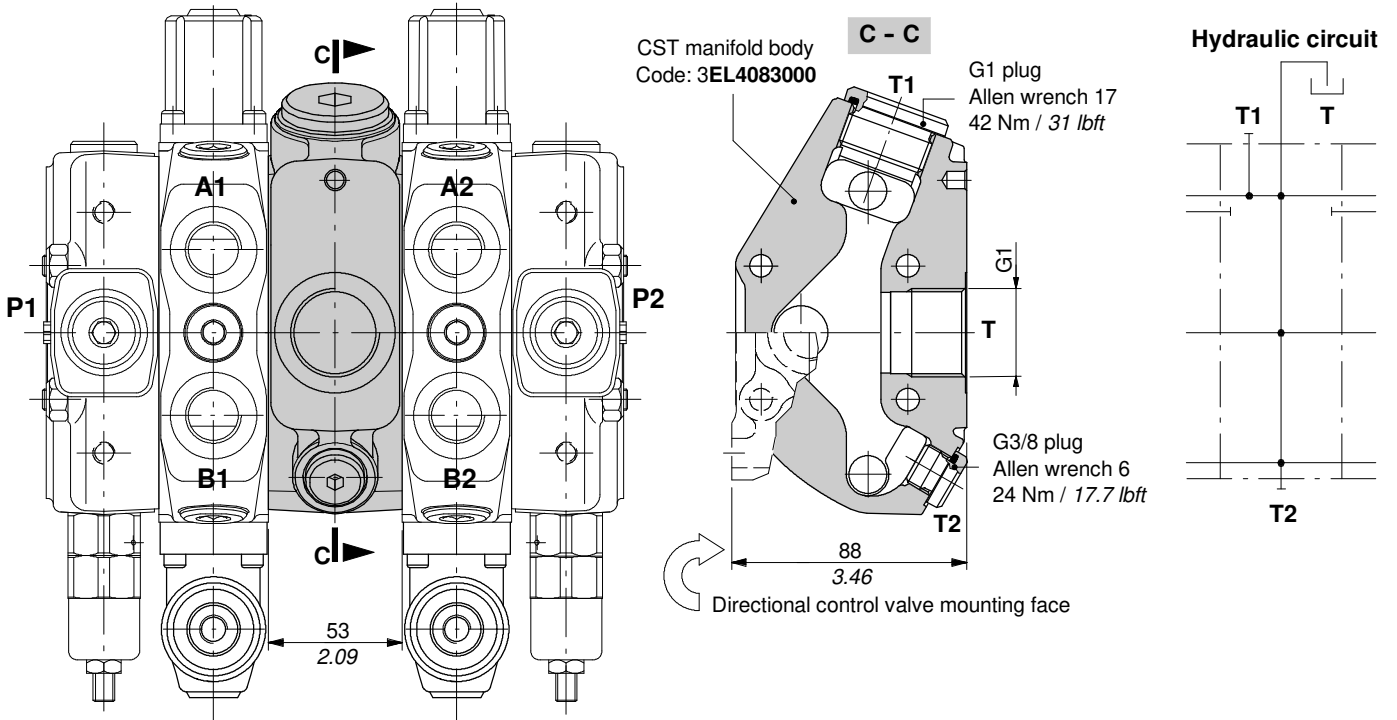

Description example: SD8/2/AC(YG3-175)/18L/CSMT/18L/BC(YG3-175)

Type CS1

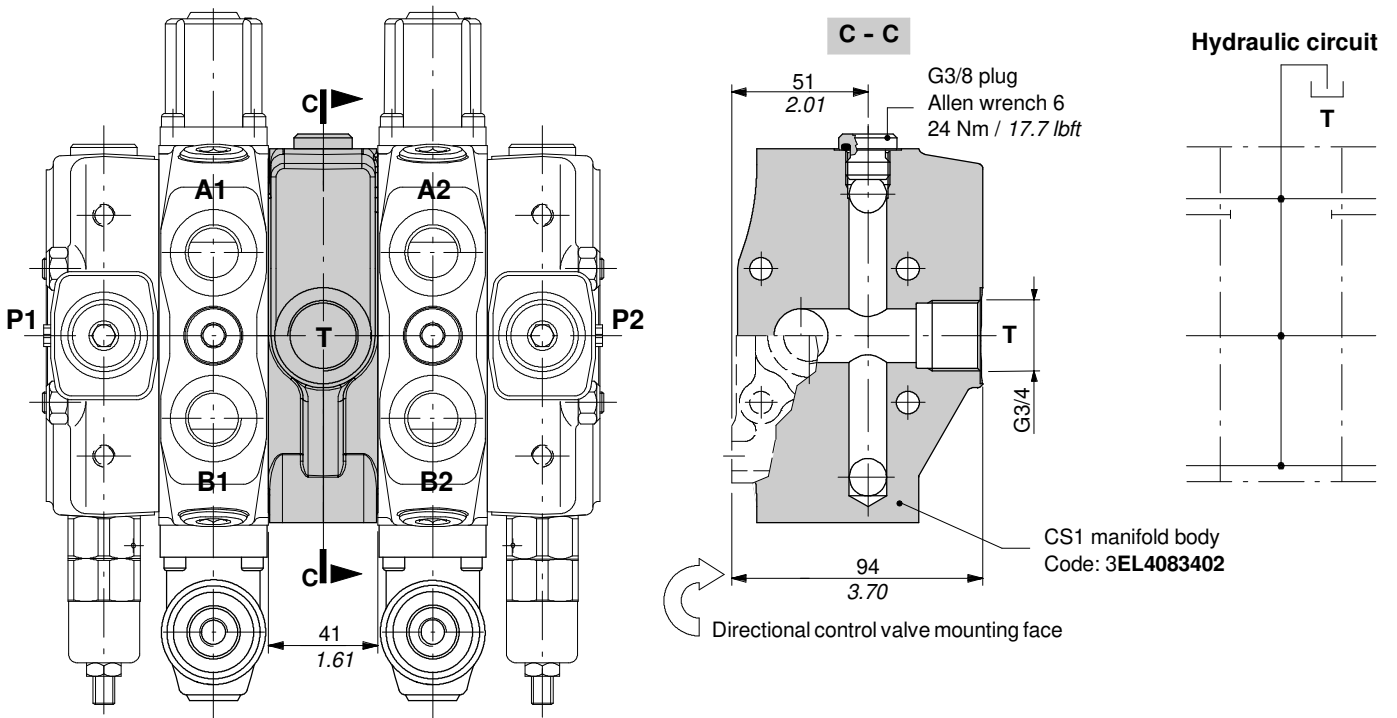

Description example: SD8/2/AC(YG3-175)/18L/CS1/18L/BC(YG3-175)

**DFG pressure compensated flow divider section**

The flow on the downstream sections can be adjusted from 0 to 80 l/min by means of graduated handwheel; flow exceeding setting goes to tank.

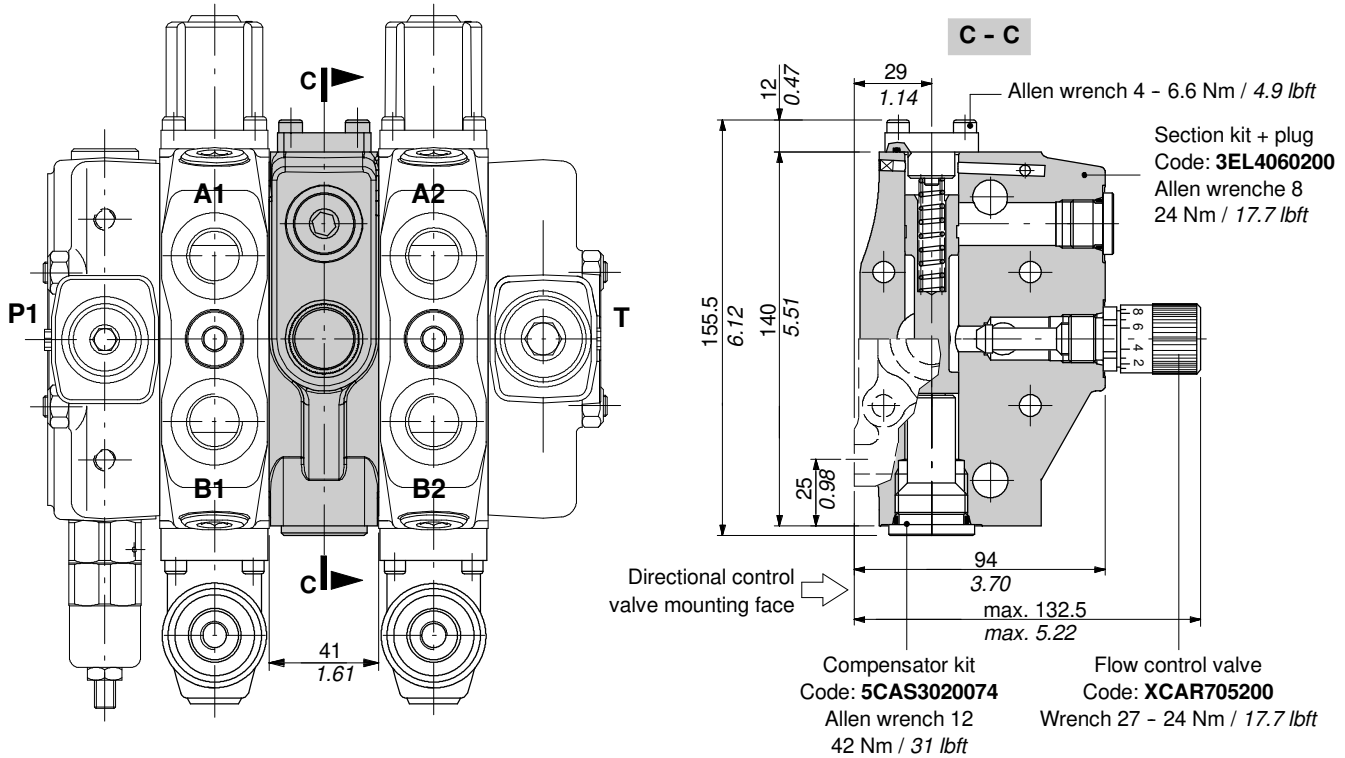

**Hydraulic circuit**

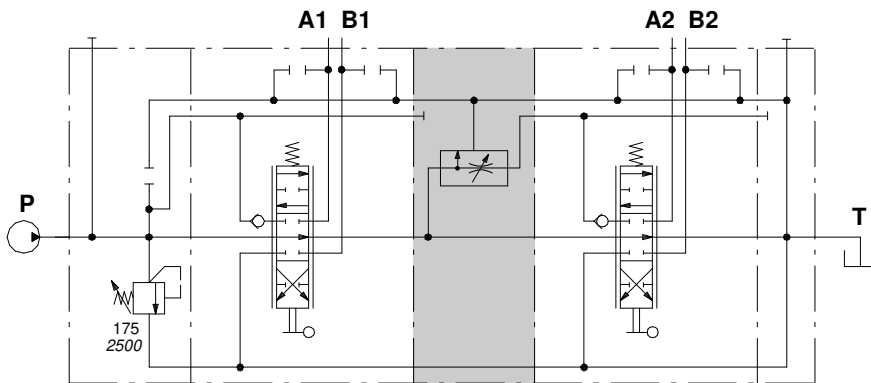

Description example: SD8/2/AC(YG3-175)/18L/DFG/18L/RC

**Flow regulation diagram**

P = 100 bar / 1450 psi

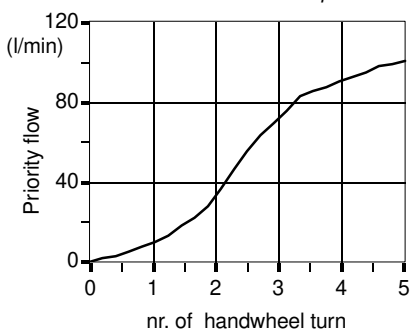

**Pressure-flow diagram**

Q<sub>in</sub> = 110 l/min

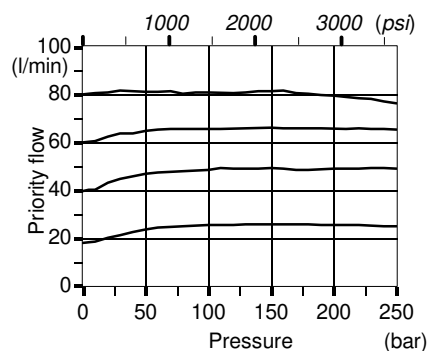

El service relief valve sections

The operation of up stream section exclude the EI downstream section; the pressure of the downstream sections should be adjusted at least 20 bar / 290 psi below the relief valve setting.

The relief cavity is the same of the one in the inlet cover; it allows to use direct operated (type Y) as well as pilot operated (type X) relief valves

Execution EI2 is prearranged for a second inlet.

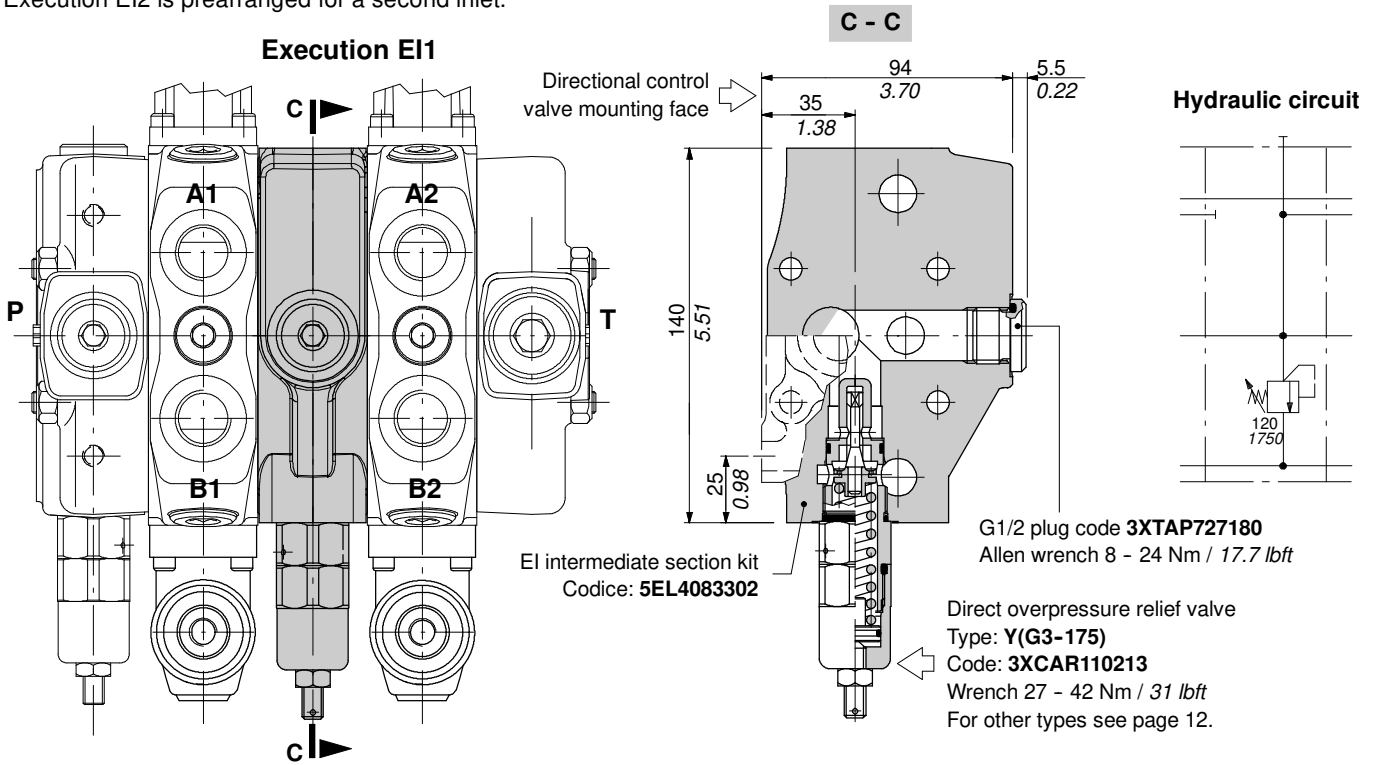

Description example: SD8/2/AC(YG3-175)/18L/EI1(YG3-120)/18L/RC

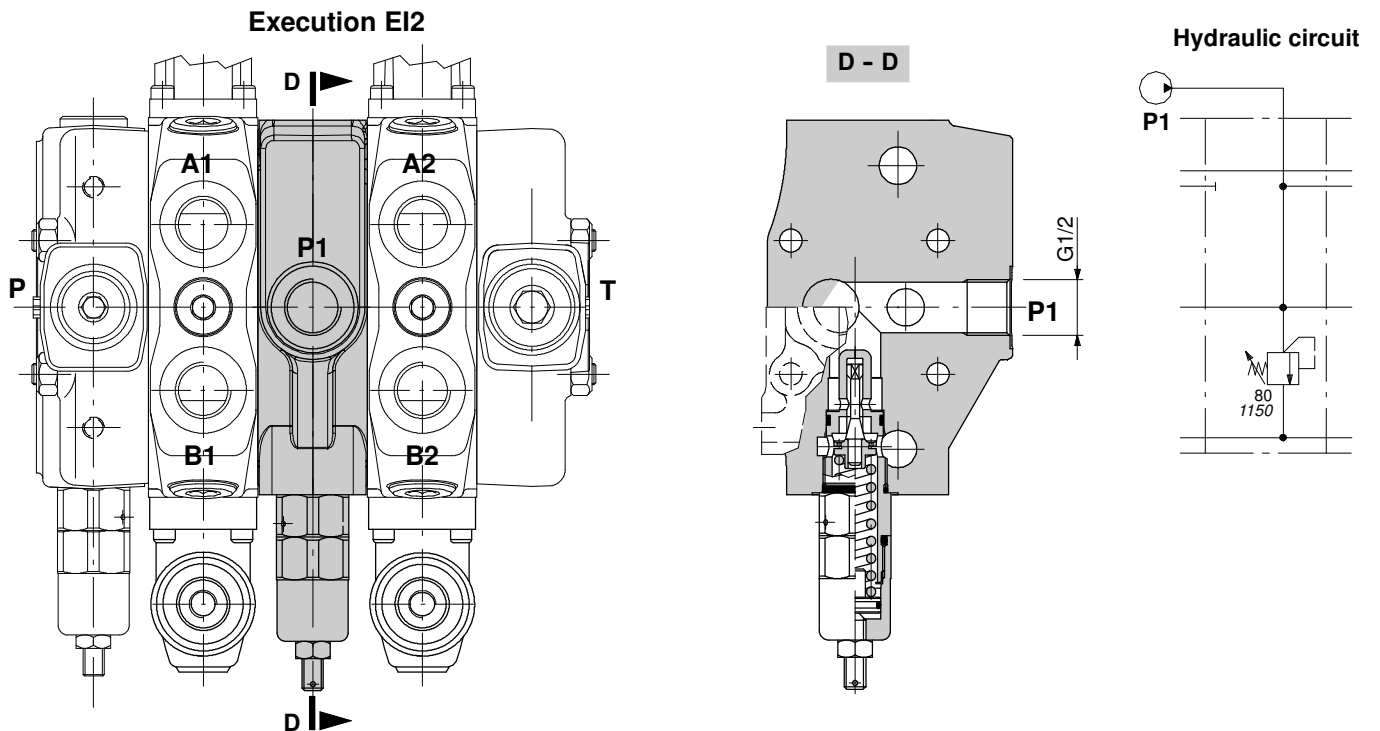

Description example: SD8/2/AC(YG3-175)/18L/EI2(YG2-80)/18L/RC

## Ordering codes

### Description example:

FS SD8 / RC \*



### Available configurations

RC: with side outlet

RD: with upper outlet

RE: with side carry-over

RK: with closed centre

See page 31.

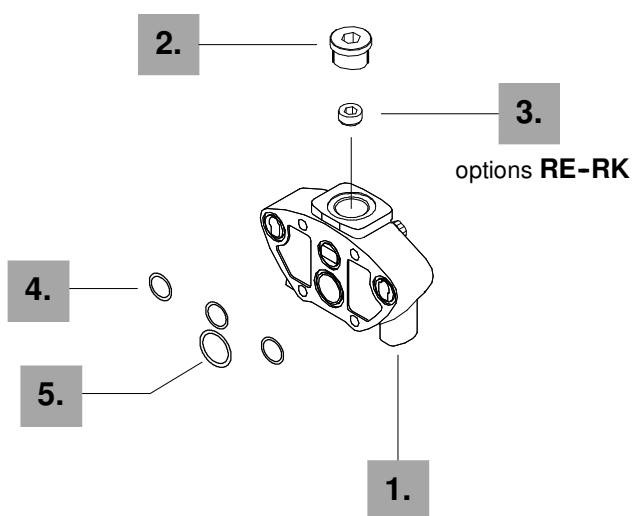

### Outlet cover parts

N°	CODE	QTY	DESCRIPTION
1.	3FIA208300	1	Outlet cover body *
2.	3XTAP732200	1	Plug G 3/4 *
4.	4GUA118818	3	O-ring seal 18.77x1.78 NBR 70 SH
5.	4GUA125118	1	O-ring seal 25.12x1.78 NBR 70 SH

### Circuit options

N°	CODE	QTY	DESCRIPTIONS
3.	4TAP318010	1	Plug M18x1.5 for carry-over (RE) and closed centre (RK) options

NOTE (\*) - Items are referred to **BSP** thread.

Type RC

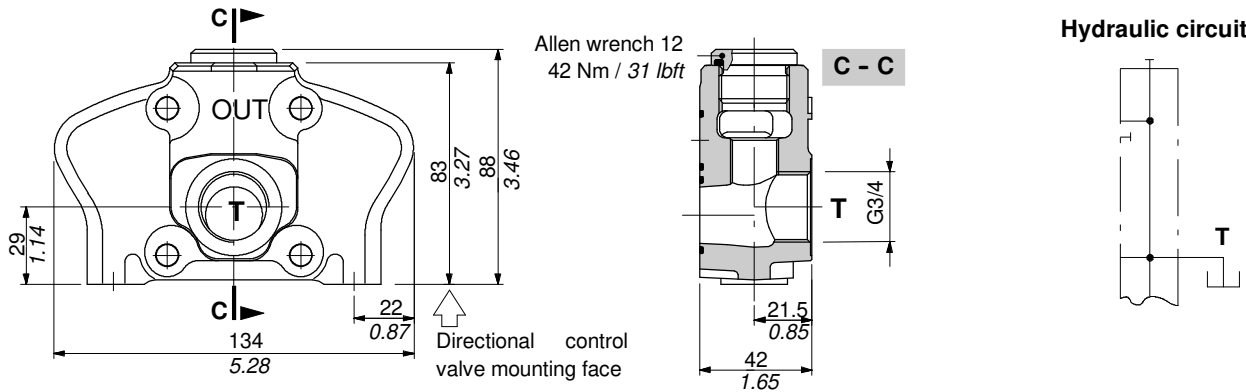

Type RD

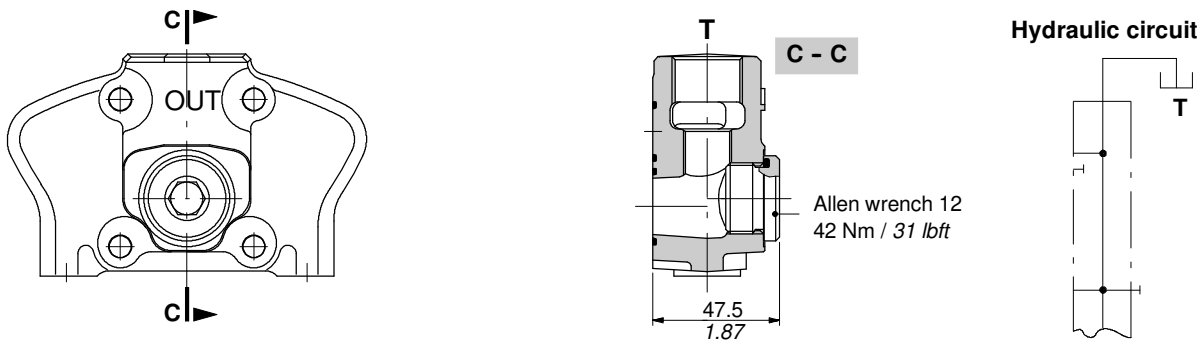

Type RE

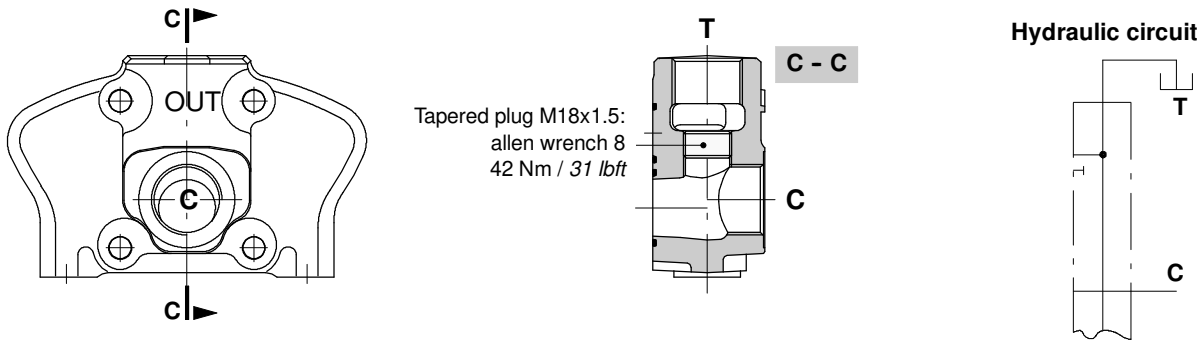

Type RK

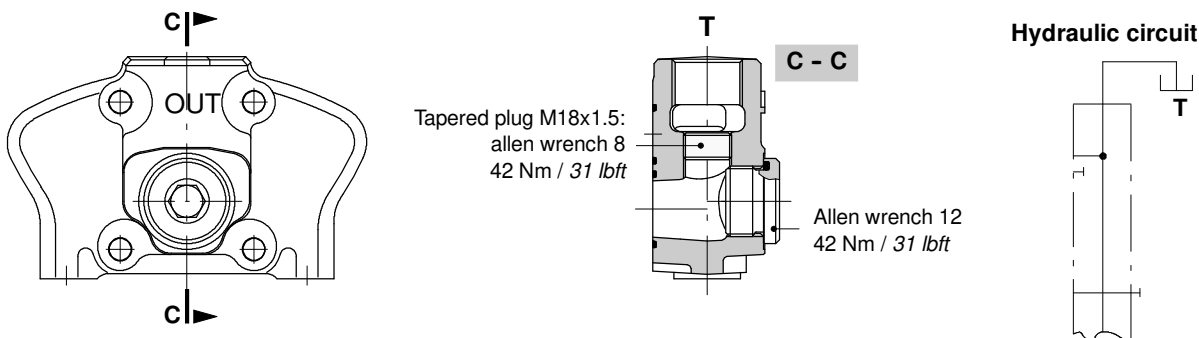

## Working conditions

This catalogue shows technical specifications and diagrams measured with mineral oil of 46 mm<sup>2</sup>/s - 46 cSt viscosity at 40°C temperature.

Max. flow rating (with stand by 15 bar / 218 psi)	<i>on inlet port P</i>	120 l/min	
	<i>on ports A and B</i>	100 l/min	
Operating pressure (maximum)		315 bar	4600 psi
Back pressure (maximum)	<i>on outlet port T</i>	25 bar	360 psi
Internal leakage A(B)→T	$\Delta p=100 \text{ bar} - 1450 \text{ psi}$ <i>fluid and valve at 40°C</i>	3 cm <sup>3</sup> /min	0.18 in <sup>3</sup> /min
Fluid		Mineral base oil	
Fluid temperature	<i>with NBR1. (BUNA-N) seals</i>	from -20° to 80°C	
	<i>with FPM (VITON) seals</i>	from -20° to 100°C	
Viscosity	<i>operating range</i>	from 15 to 75 mm <sup>2</sup> /s	<i>from 15 to 75 cSt</i>
	<i>min.</i>	12 mm <sup>2</sup> /s	12 cSt
	<i>max.</i>	400 mm <sup>2</sup> /s	400 cSt
Max level of contamination		19/16 - ISO 4406	
Ambient temperature		from -40° to 60°C	
Tie rod tightening torque		30 Nm	22.2 lbft

NOTE - For different conditions please contact Sales Dept.

## Dimensional data (with inlet flow control valve)

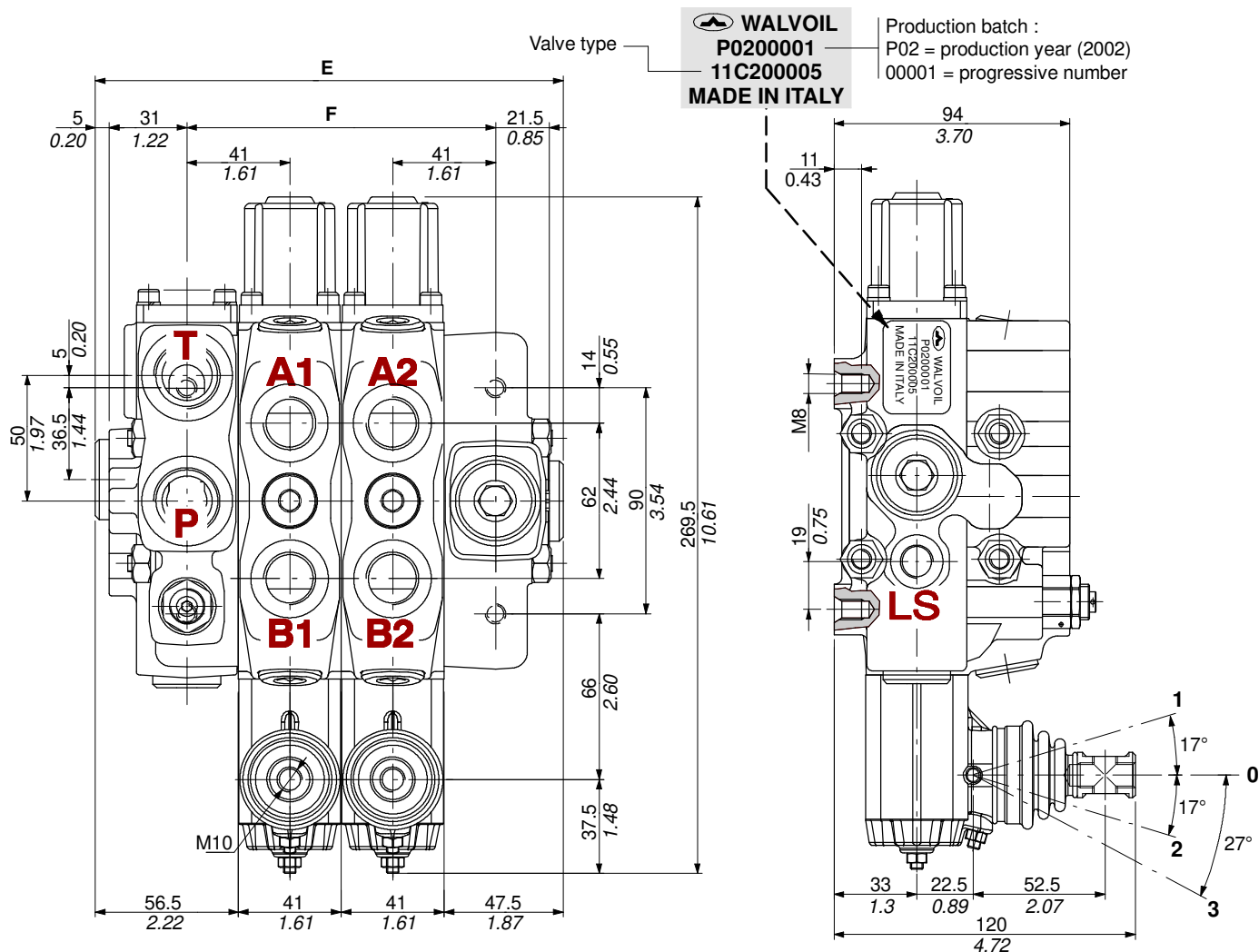

TYPE	E		F		Weight	
	mm	in	mm	in	kg	lb
<b>DLS8/1</b>	145	5.71	82	3.23	8.6	19
<b>DLS8/2</b>	186	7.32	123	4.84	12.3	27.1
<b>DLS8/3</b>	227	8.93	164	6.46	16	35.3
<b>DLS8/4</b>	268	10.55	205	8.07	19.7	43.4
<b>DLS8/5</b>	309	12.16	246	9.68	23.4	51.6

TYPE	E		F		Weight	
	mm	in	mm	in	kg	lb
<b>DLS8/6</b>	350	13.78	287	11.3	26.9	59.3
<b>DLS8/7</b>	391	15.39	328	12.91	30.6	67.5
<b>DLS8/8</b>	432	17	369	14.52	34.3	75.7
<b>DLS8/9</b>	473	18.61	410	16.13	38	83.9
<b>DLS8/10</b>	514	20.22	451	17.74	41.7	92.1

### Standard threads

PORTS	BSP (ISO 228/1)	UN-UNF (ISO 11926-1)	METRIC (ISO 6149-1)
Inlet <b>P</b>	G 3/4	7/8-14 (SAE 10)	M22x1.5
Outlet <b>T</b>	G 3/4	7/8-14 (SAE 10)	M27x2
<b>A</b> and <b>B</b> ports	G 1/2	3/4-16 (SAE 8)	M22x1.5
Load sensing <b>LS</b>	G 1/4	9/16-18 (SAE 6)	M14x1.5
PILOT PORTS			
Pneumatic	NPTF 1/8-27	NPTF 1/8-27	G 1/4
Hydraulic	G 1/4	9/16-18 (SAE 6)	NPTF 1/8-27

## Hydraulic circuit

### Fixed displacement pump (open centre)

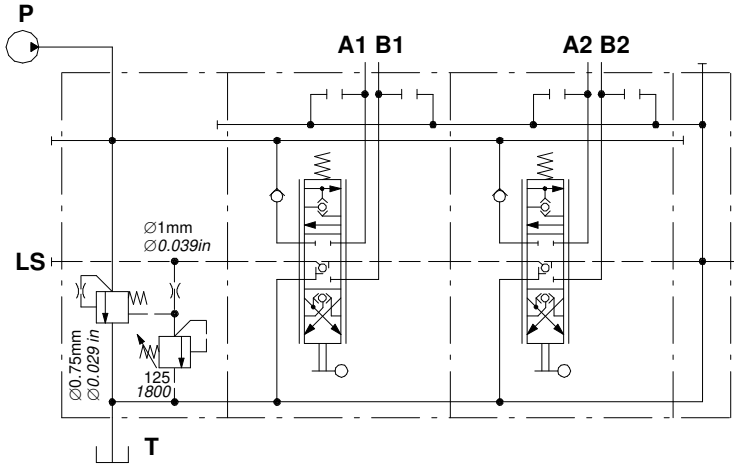

Description example:  
DLS8/2/**AM**(G3-125)/6N8LF3/6N8LF3/RF

### Variable displacement pump with Load-Sensing flow control (closed centre)

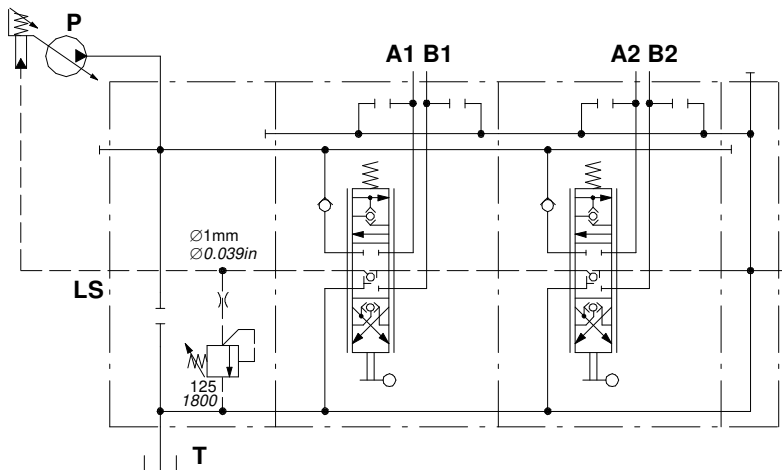

Description example :  
DLS8/2/**AN**(G3-125)/6N8LF3/6N8LF3/RF

Configuration with L.S. relief valve is also available.

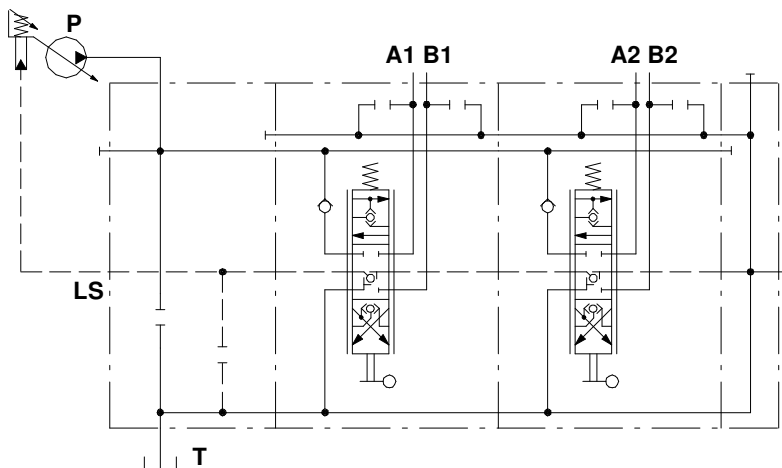

Description example :  
DLS8/2/**AP**(SV)/6N8LF3/6N8LF3/RF

## Performance data (pressure drop vs. flow)

### Open centre

From top inlet to top outlet.

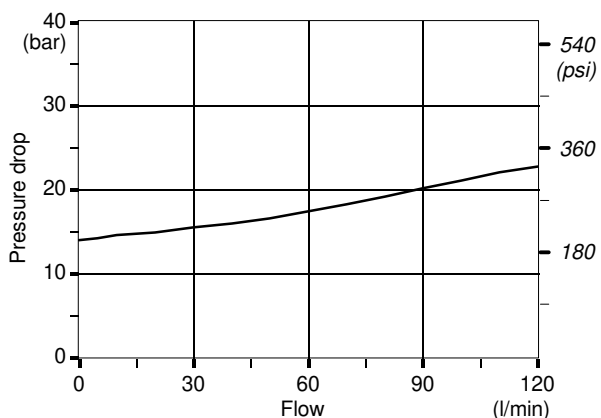
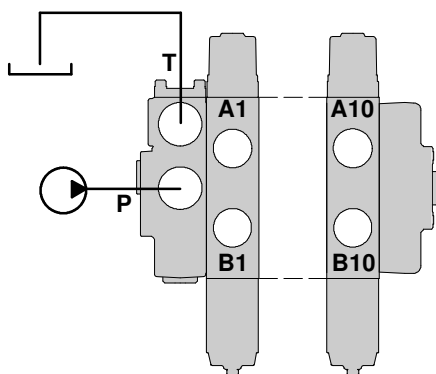

### Inlet to work port

From top inlet to **A** port (spool in position 1) or **B** port (spool in position 2).

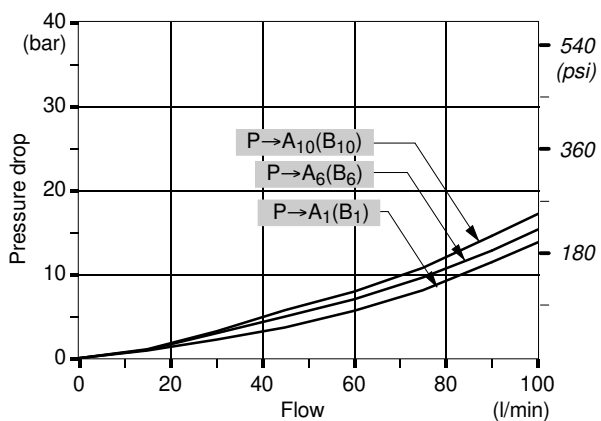
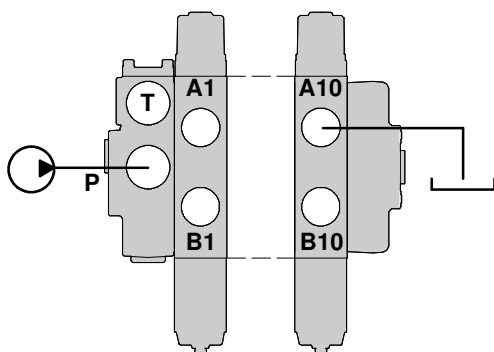

### Work port to outlet

From **A** port (spool in position 2) or **B** port (spool in position 1) to top outlet.

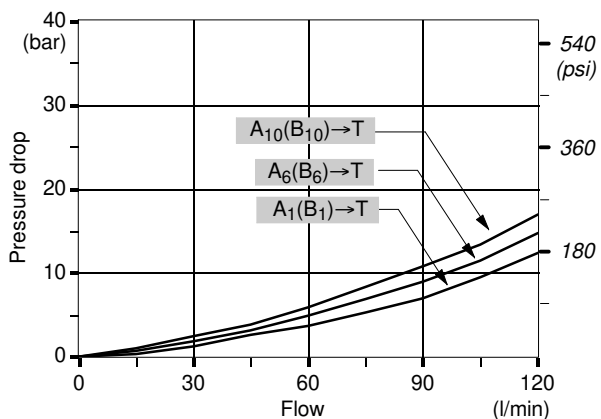
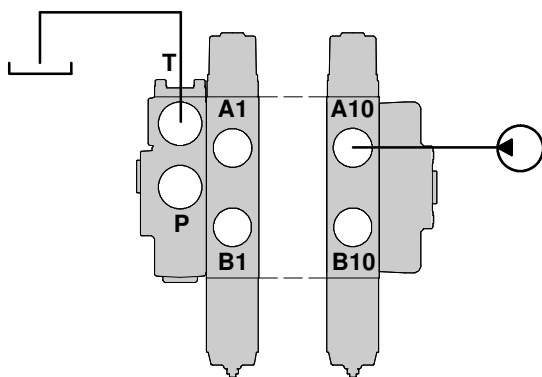

NOTE - Measured with spool type 6N.



**1. Complete inlet / outlet cover \* *page 38***

TYPE	CODE	DESCRIPTION
<b>AM(G3-120)</b>	61C331000	With flow control valve and L.S. overpressure relief valve
<b>AP(SV)</b>	61C333000	Without flow control valve and L.S. overpressure relief valve
<b>AN(G3-120)</b>	61C332000	Without flow control valve, with L.S. overpressure relief valve

**2. Complete working section \* *page 42***

TYPE	CODE	DESCRIPTION
<b>Q-6N8LF3</b>	61C151001	Parallel circuit, double acting spool with spring return, lever control
<b>P-6N8LF3</b>	61C131601	As previous, prearranged for port valves.

**3. Return cover \* *pag. 47***

TYPE	CODE	DESCRIPTION
<b>RF</b>	61C431000	Standard type

**4. Assembling kit**

CODE	DESCRIPTION
5TIR108128	tie rods with nuts for 1 sections
5TIR108169	tie rods with nuts for 2 sections
5TIR108210	tie rods with nuts for 3 sections
5TIR108251	tie rods with nuts for 4 sections
5TIR108292	tie rods with nuts for 5 sections
5TIR108333	tie rods with nuts for 6 sections
5TIR108374	tie rods with nuts for 7 sections
5TIR108415	tie rods with nuts for 8 sections
5TIR108456	tie rods with nuts for 9 sections
5TIR108497	tie rods with nuts for 10 sections

NOTE (\*) - Items are referred to **BSP** thread.

## Ordering codes

### Description example:

FE DLS8 / A M (G3 - 125) \*

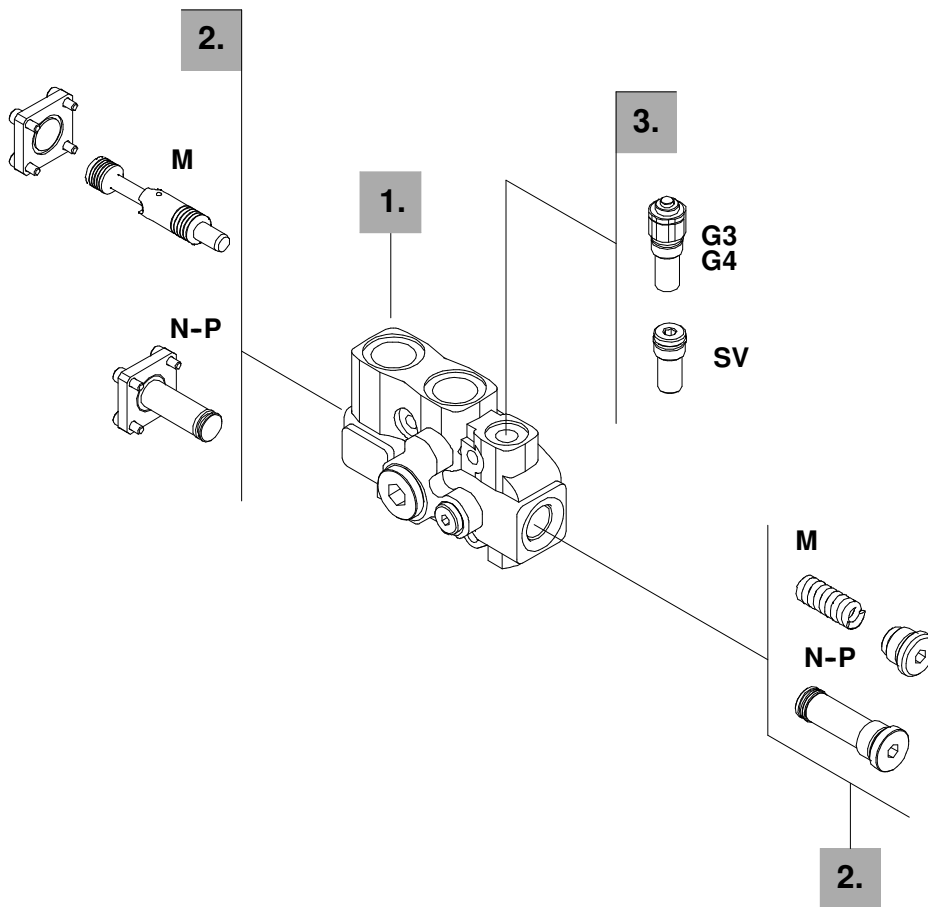
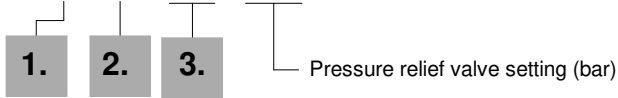

### 1. Cover body kit \* page 39

CODE	DESCRIPTION
5FIA308310	Type AM
5FIA308311	Type AN
5FIA308312	Type AP

### 2. Flow control valve option page 39

TYPE	CODE	DESCRIPTION
(M)	5KIT008300	Flow control kit (stand by 15 bar / 218 psi)
(N)-(P)	5KIT008310	Flow control blanking kit

### 3. Inlet relief options page 41

TYPE	CODE	DESCRIPTION
<u>On Load-sensing signal</u>		
(G3-120)	XCAR602100	Range 100 to 200 bar / 1450 to 2900 psi standard setting 120 bar / 1800 psi
(G4-250)	XCAR602200	Range 160 to 315 bar / 2320 to 4570 psi standard setting 250 bar / 3600 psi
<i>Standard setting is referred to 10 l/min flow.</i>		
(SV)	XTAP220440	Relief valve blanking plug

NOTE (\*) - Codes are referred to **BSP** thread.

**Dimensional data**

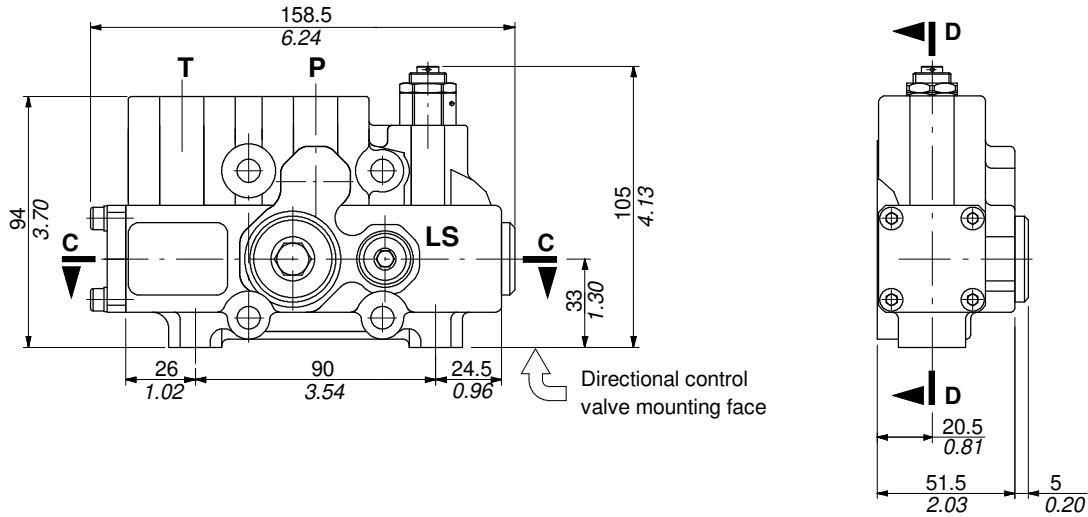

**Type AM with flow control valve and L.S. overpressure relief valve**

For systems with fixed displacement pumps (open centre version); see page 34.

Cover body kit is composed of body (1), plugs (2-3), flow limiter (4) and mounting O-ring seals.

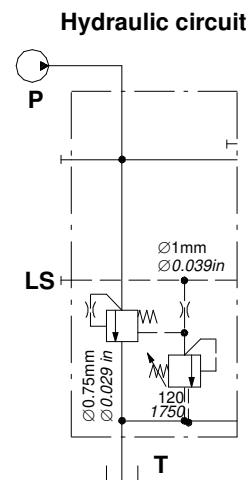
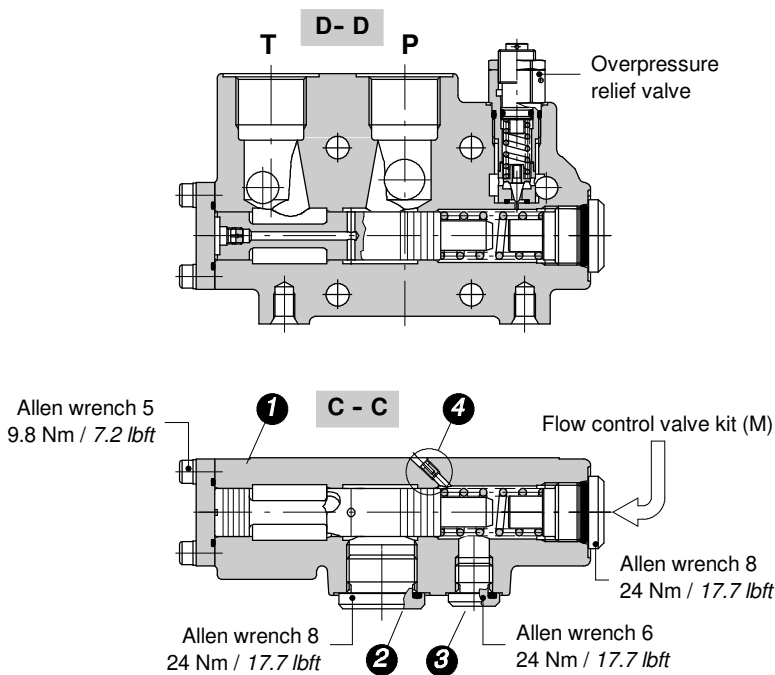

**Cover body kit**

**Type AP without flow control valve and L.S. overpressure relief valve**

For systems with variable displacement pumps (closed centre version); see page 34.

Cover body kit is composed of body (1), plug (2) and mounting O-ring seals.

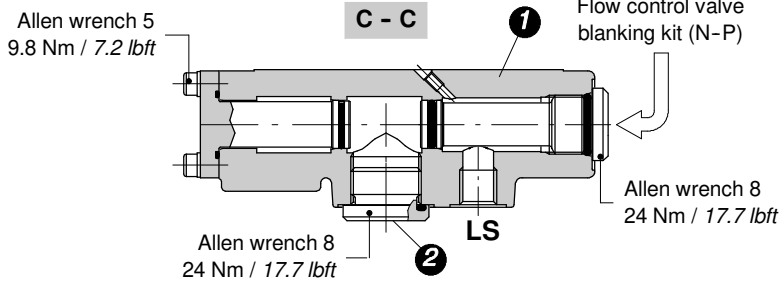
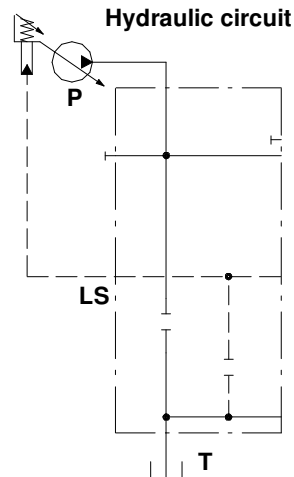
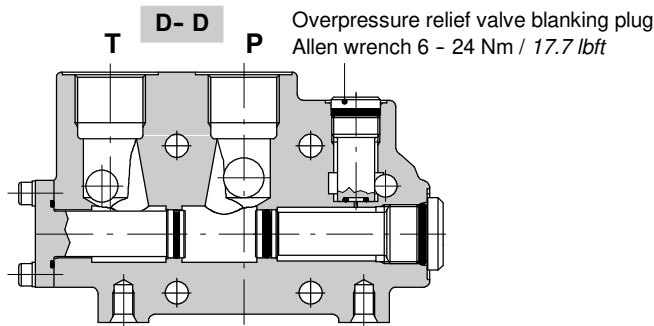

**Type AN without flow control valve, with L.S. overpressure relief valve**

For systems with variable displacement pumps (closed centre version); see page 34.

Cover body kit is composed of body (1), plug (2), flow limiter (4) and mounting O-ring seals.

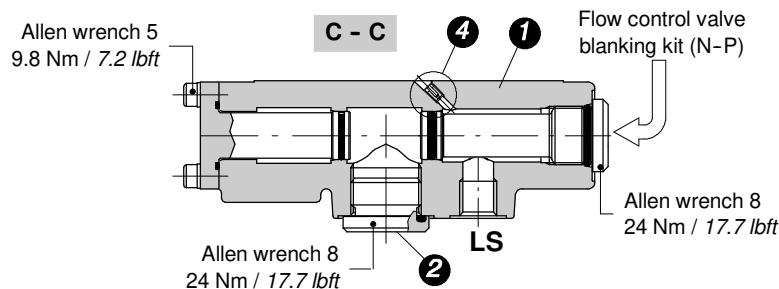
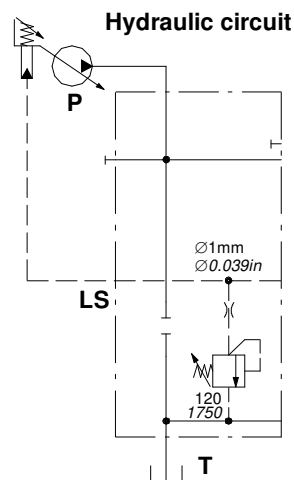
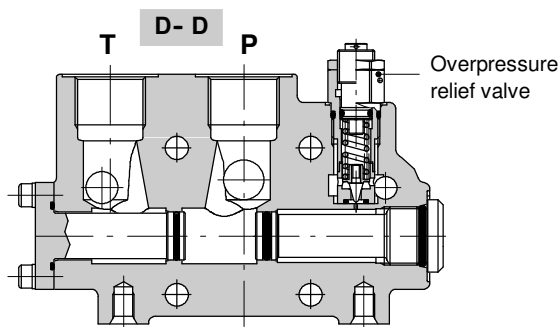

**Direct overpressure relief valve**

**LS ( G 3 - 120 )**

- Pressure setting in bar (for standard value see page 61)
- Adjustable spring type (3, 4).
- Adjustment type (G, H)

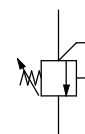

**Adjustment type**

**G:** with screw

**H:** valve set and locked

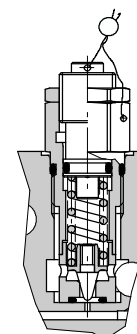
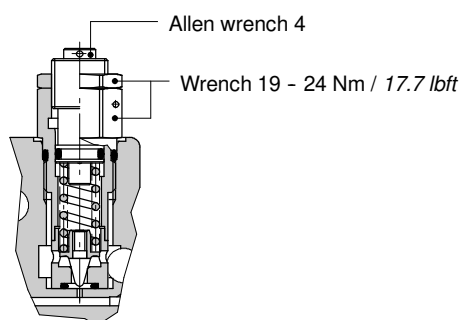

**Performance data**

**Spring nr. 3 (blue band)**

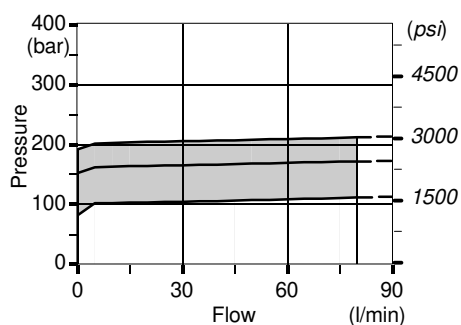

**Spring nr.4 (red band)**

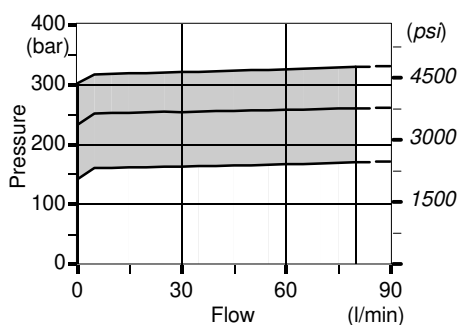

**Time response**

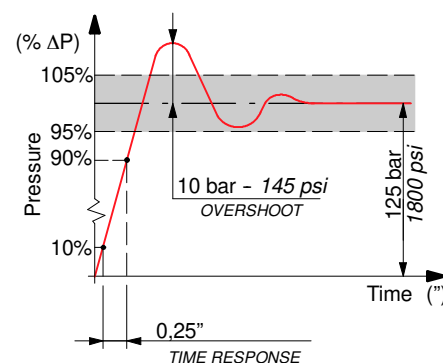

## Ordering codes

Description example:

EL DLS8 / P - 6N 8 LF3 . P 3 (G3 - 120) \*

1. 2. 3. 4. 5.

1 mounted on A port.  
2 mounted on B port.  
3 mounted on A and B ports.

Port relief valve setting in bar

EL DLS8 / P - 6N 8IMF3

6.

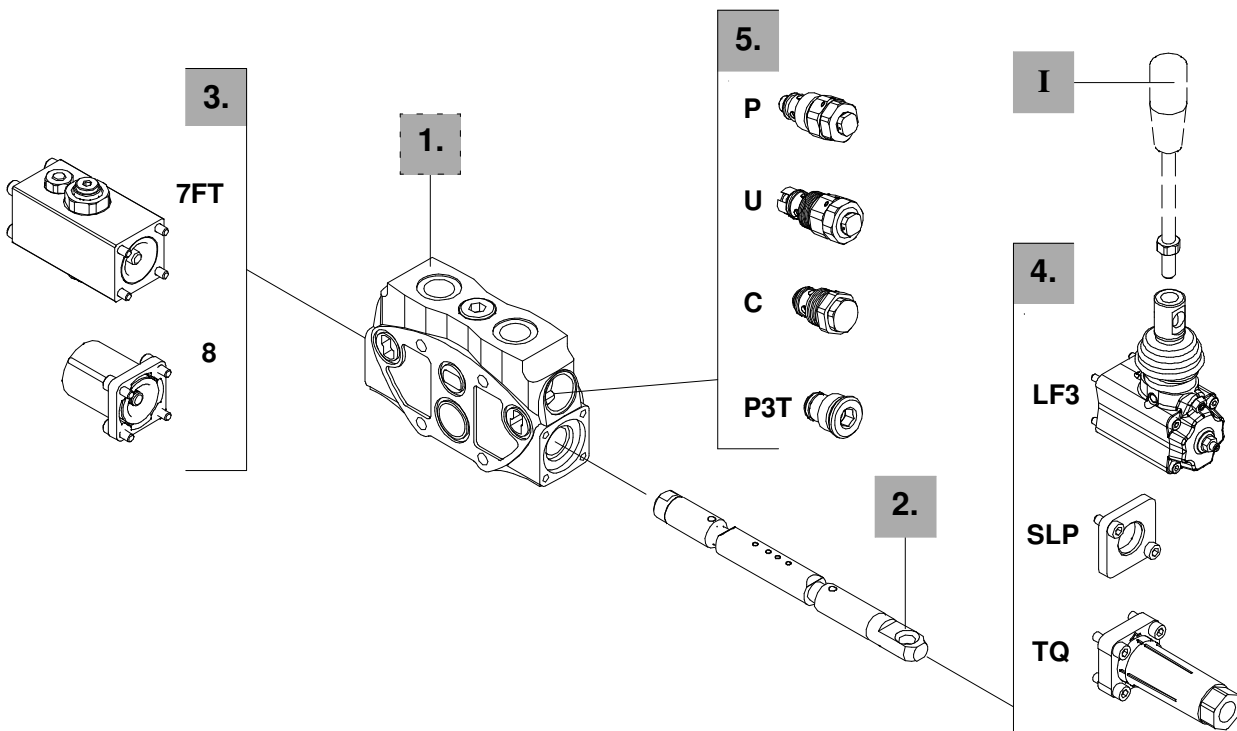

**1. Working section kits \* page 20**

TYPE	CODE	DESCRIPTION
<b>Q</b>	5EL1083010	Without port valves prearrangement
<b>P</b>	5EL1083000	With port valves prearrangement

Include boby, seals, rings and load check valve.

**2. Spool page 44**

TYPE	CODE				DESCRIPTION
	20 l/min	40 l/min	60 l/min	90 l/min	
	<b>V</b>	<b>Q</b>	<b>S</b>	<b>N</b>	Nominal flow with 15 bar / 218 psi stand-by
<b>6</b>	3CU3410020	3CU3410040	3CU3410060	3CU3410090	Double acting, 3 position, with A and B closed in neutral position
<b>7</b>	3CU3425020	3CU3425040	3CU3425060	3CU3425090	Double acting, 3 position, with A and B to tank in neutral position

Special spools for particular positioner kits

<b>5</b>		3CU3442060	3CU3442090	Double acting, 4 positions, flot in position 3 with spool in
----------	--	------------	------------	--

**3. "A" side spool positioners page 48**

TYPE	CODE	DESCRIPTION
<b>7FT</b>	5V07208100	With friction
<b>8</b>	5V08108000	With spring return in neutral position
<b>8PF</b>	5V08108705	Proportional pneumatic kit

**6. Complete controls \* page 60**

Proportional hydraulic control type **8IMF3** with spool stroke limiters.

**4. "B" side options page 57**

TYPE	CODE	DESCRIPTION
<b>LF3</b>	5LEV108710	Lever box with adjustable flow limiters
<b>SLP</b>	5COP108000	Without lever box, with dust-proof plate
<b>TQ</b>	5TEL108110	Flexible cable connection; for CD cables

**I Optional handlevers**

TYPE	CODE	DESCRIPTION
<b>AL01/M10x200</b>	170012020	For LF3 lever box L= 200 mm/7.87in

**5. Port relief valves page 64**

TYPE	CODE	DESCRIPTION
<u>Anti-shock valve</u>		
<b>P(G3-100)</b>	3XCAR208113	Range 63 to 220 bar / 900 to 3200 psi standard setting 100 bar / 1450 psi
<b>P(G4-200)</b>	3XCAR208114	Range 180 to 350 bar / 2600 to 5050 psi standard setting 200 bar / 2900 psi
<u>Anti-shock and anti-cavitation valve</u>		
<b>U(G2-63)</b>	XCAR308112	Range 63 to 125 bar / 900 to 1800 psi standard setting 63 bar / 900 psi
<b>U(G3-100)</b>	XCAR308115	Range 100 to 250 bar / 1450 to 3600 psi standard setting 100 bar / 1450 psi
<b>U(G4-200)</b>	XCAR308114	Range 200 to 315 bar / 2900 to 4600 psi standard setting 200 bar / 2900 psi
Standard setting is referred to 10 l/min flow.		
<b>C</b>	XCAR408110	Anti-cavitation
<b>P3T</b>	3XTAP524290	A and B ports valve blanking plugs

NOTE (\*) - Items are referred to BSP thread.

Spools

Type 6N

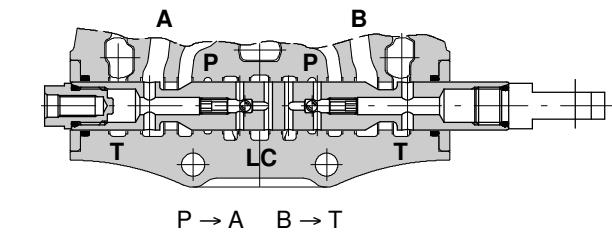

stroke + 7 mm  
+ 0.28 in

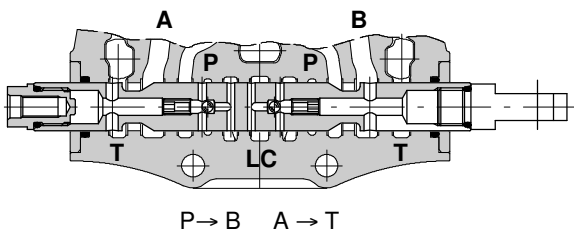
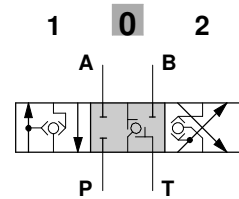
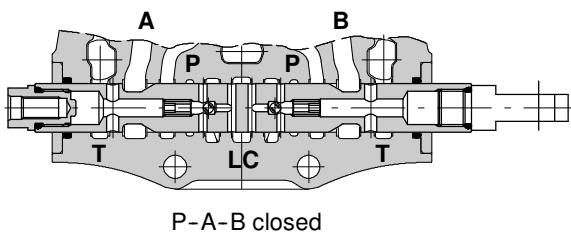
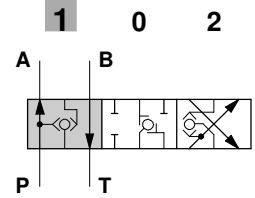

stroke - 7 mm  
- 0.28 in

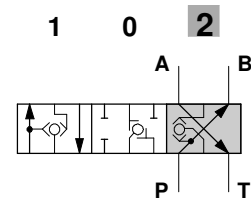

Type 7N

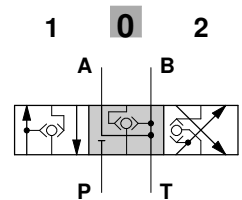
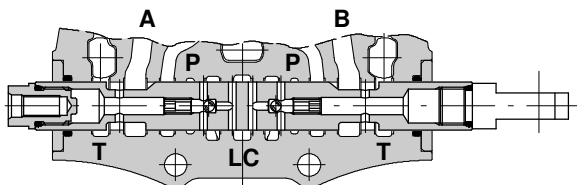

Spool metering with AM inlet cover and 15 bar / 218 psi standard stand-by

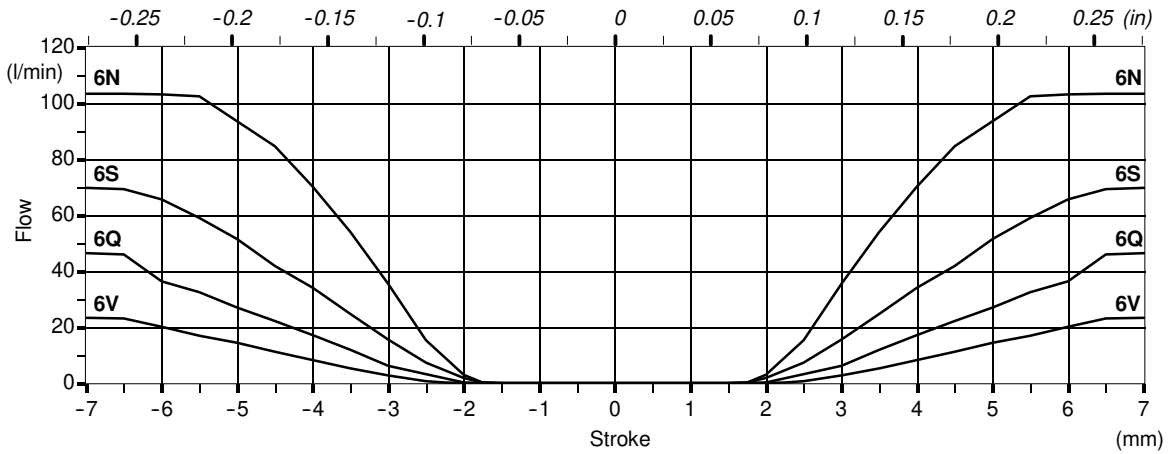

Spool metering with AN inlet cover

With 10 bar / 145 psi L.S. pump stand-by

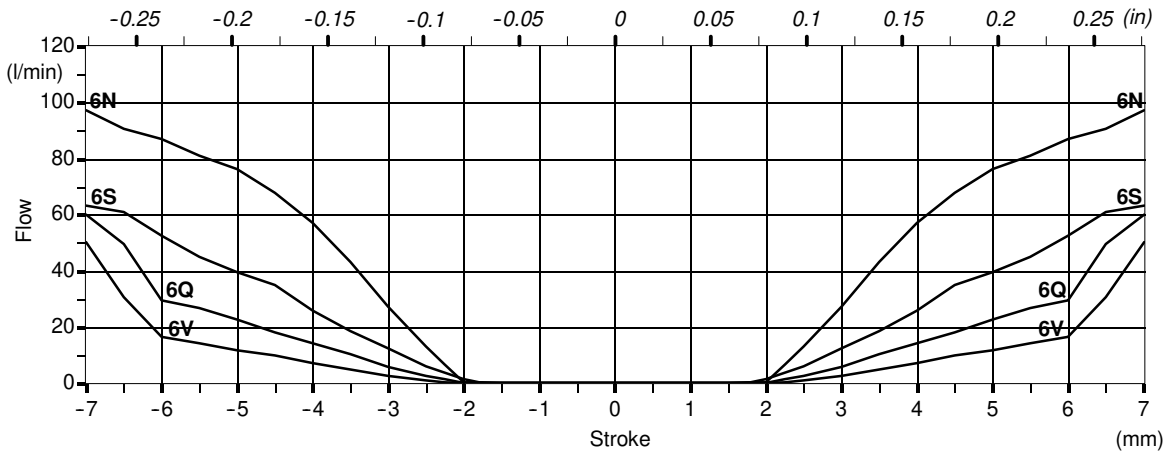

With 20 bar / 290 psi L.S. pump stand-by

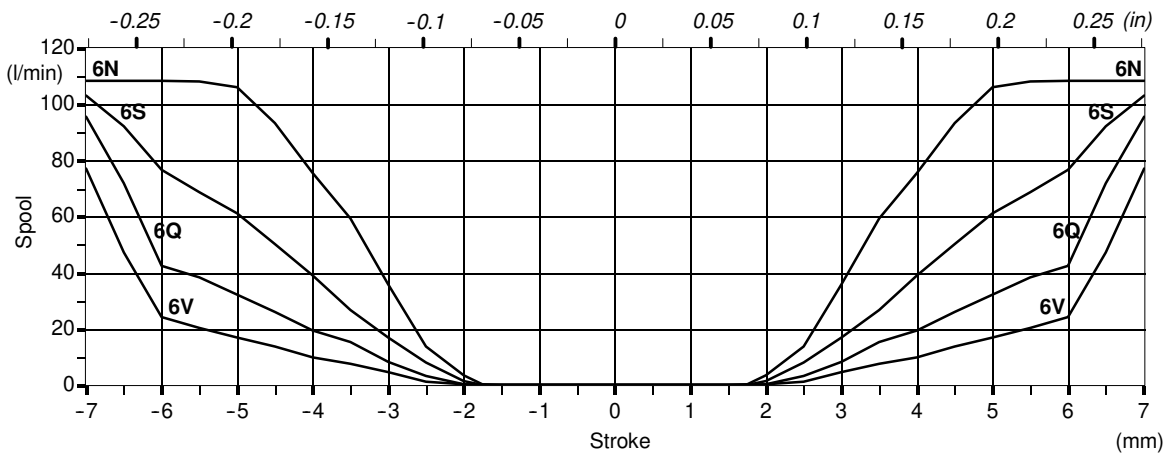

Spools

Type 5N

It needs special body with extra machining type **P-5** code **5EL5083200**. It must be coupled only with spool positioner **13** code **5V13108010**.

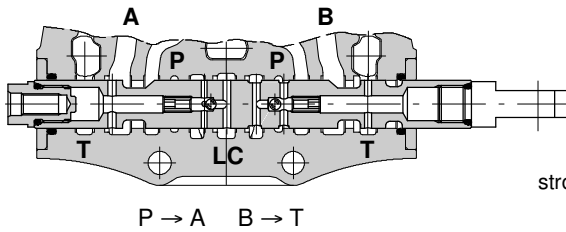

stroke + 6 mm  
+0.236 in

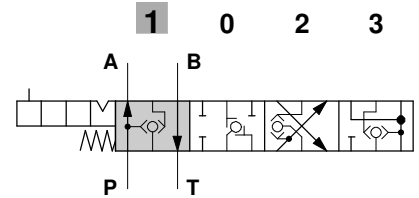

Allen wrench 4 - 6.6 Nm / 4.9 lbf

Wrench 34  
24 Nm / 17.7 lbf

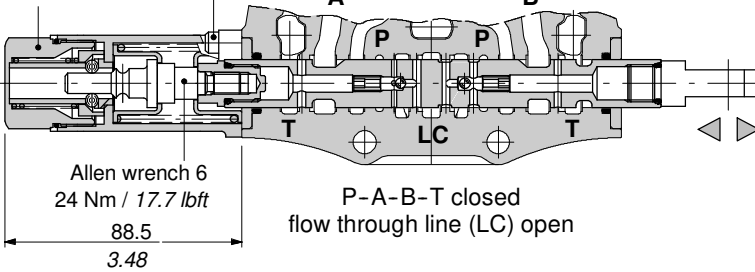

P-A-B-T closed  
flow through line (LC) open

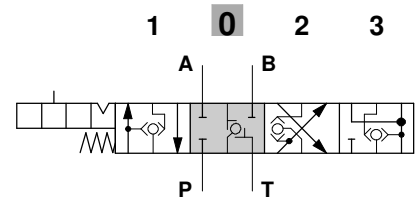

Allen wrench 6  
24 Nm / 17.7 lbf  
88.5  
3.48

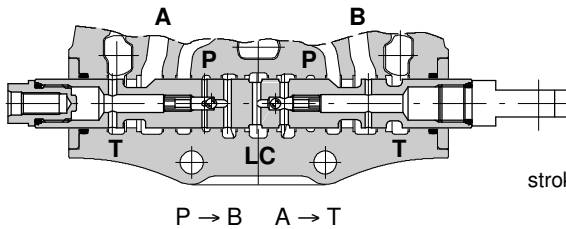

stroke - 5.8 mm  
- 0.228 in

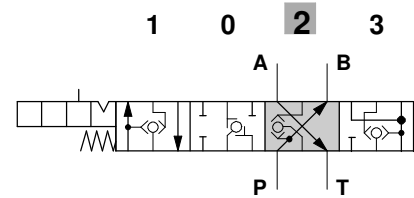

Spool positioner 13

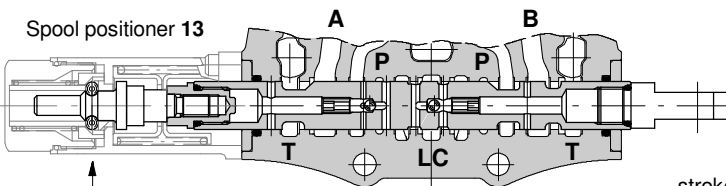

A-B → T (float in detent)

Locking force:  
330 N / 74.2 lbf ±10%  
Unlocking force:  
240 N / 54 lbf ±10%

stroke - 11.4 mm  
- 0.449 in

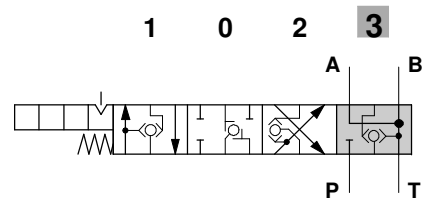

Description example:

FS DLS8 / RF \*

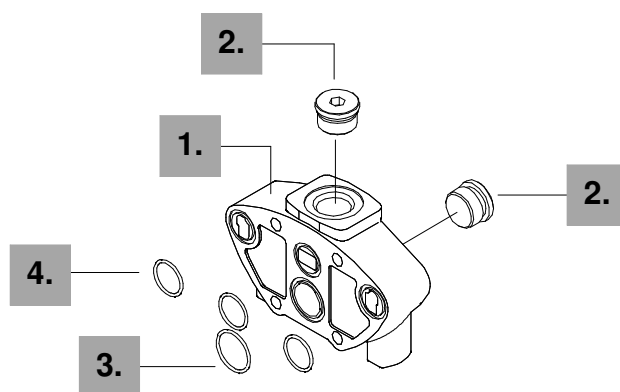

Return cover parts

N°	CODE	QTY	DESCRIPTION
1.	3FIA208300*	1	Return cover body
2.	3XTAP732200*	1	G3/4 plug
3.	4GUA118818	3	O-ring seal 18.77x1.78 NBR 70 SH
4.	4GUA125118	1	O-ring seal 25.12x1.78 NBR 70 SH

NOTA (\*) - Items are referred to **BSP** thread.

Dimensional data and hydraulic circuit

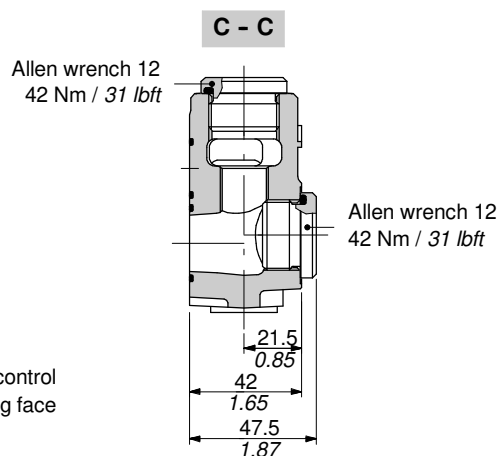
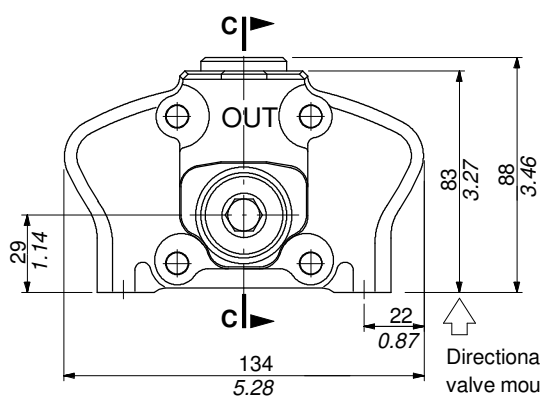

Hydraulic circuit



“A” side spool positioners

With friction type 7FT

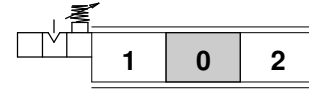
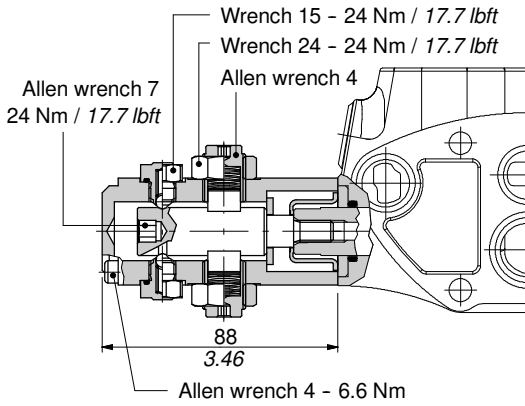

With spring return

8 kit

It's supplied with standard spring type B (see force-stroke diagram).

It's available with lighter spring type A (8MA: code 5V08108240) or heavier type C (8MC: code 5V08208000) and type D (8MD: code 5V08408000).

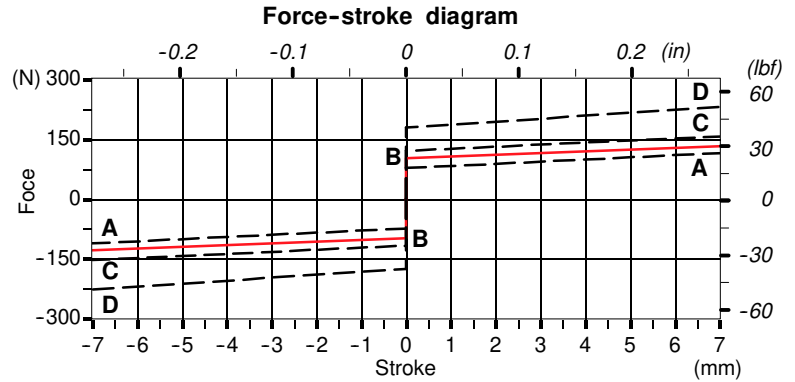
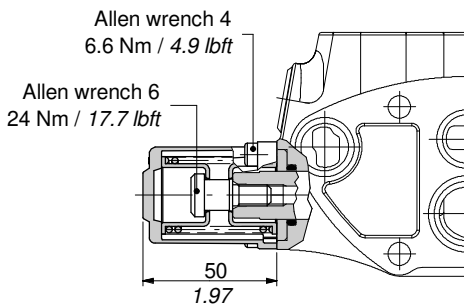

8D kit

Spool end joint code 5PER318500, is available on request in order to screw onto pin.

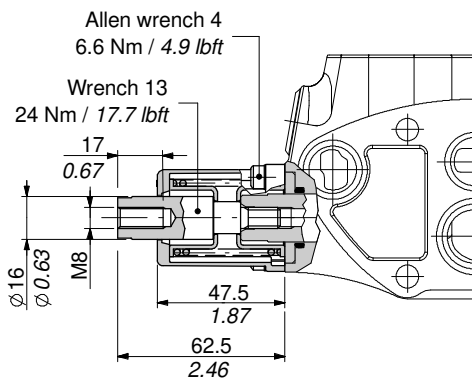

Spool end joint dimension

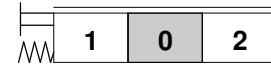
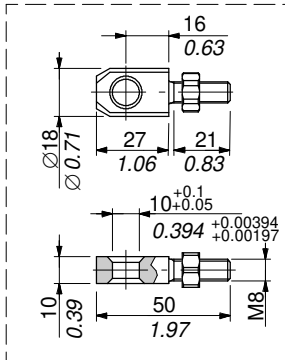

With spring return

8D1 kit

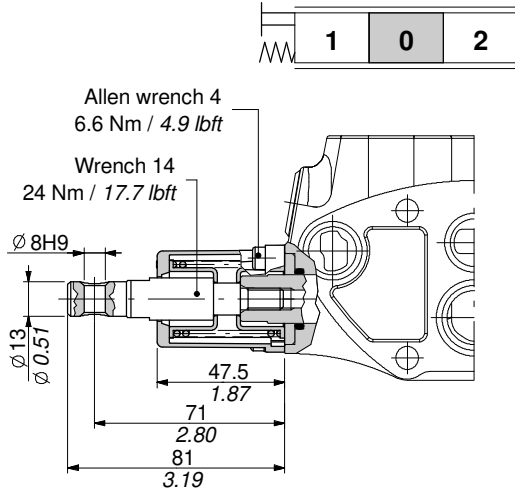

8D2 kit

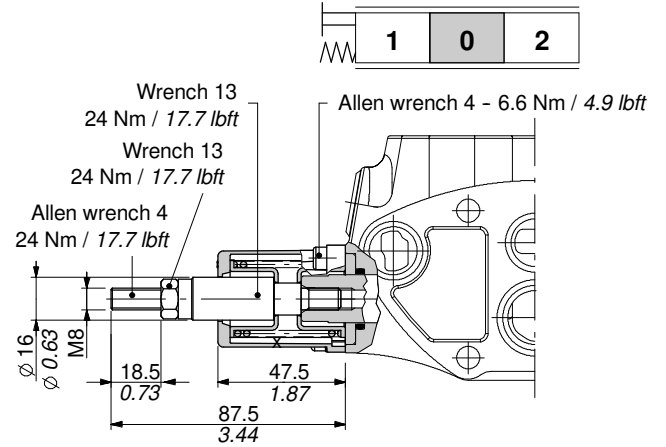

8TL kit

For connection with flexible cables it's necessary to couple 8TL kit with CP080 kit, code 5TEL408005.

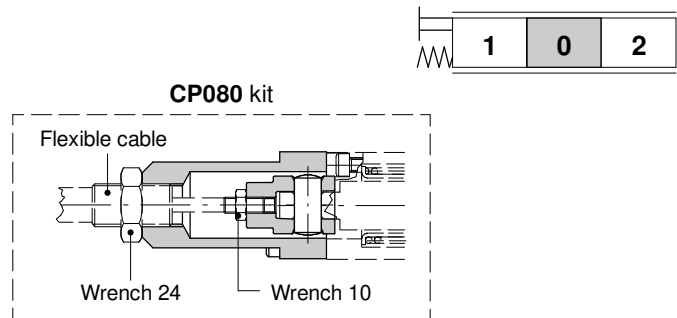
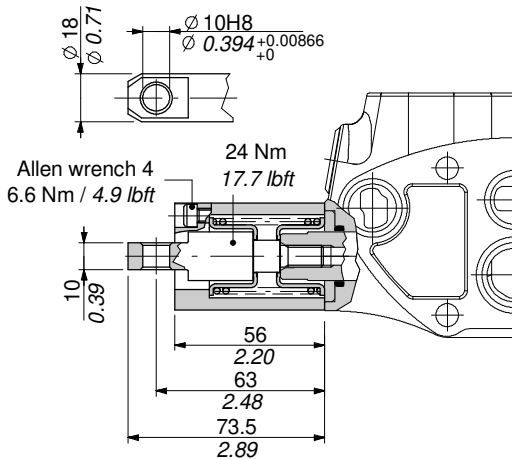

19 kit

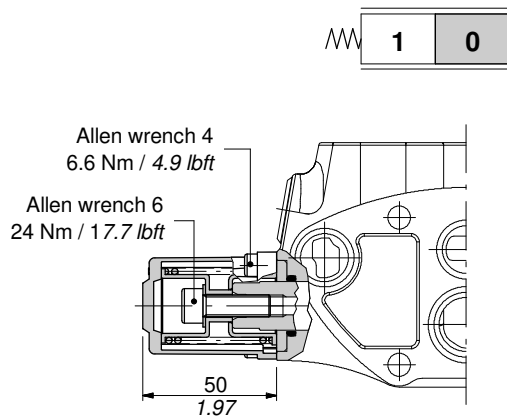

20 kit

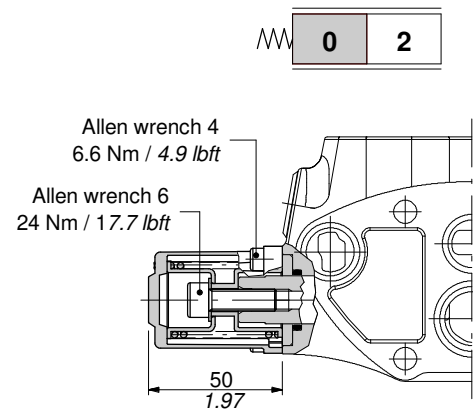

"A" side spool positioners

With external hydraulic pilot for return in neutral position

They are used along with load limiting valves.

8IJ1 kit

With return in neutral position from position 1.

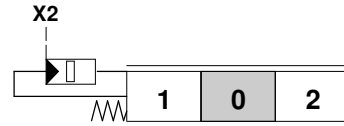
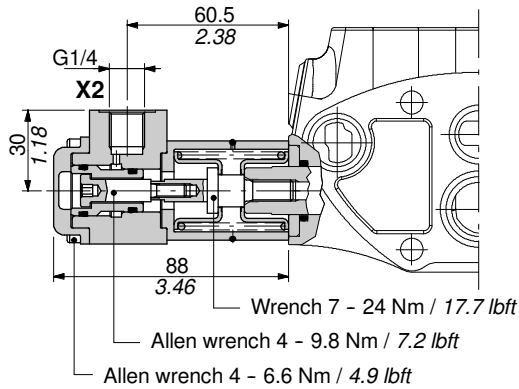

Operating features

Pilot pressure ..... : min. 50 bar / 725 psi  
max. 315 bar / 4600 psi

8IJ2 kit

With return in neutral position from position 2.

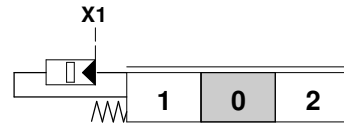
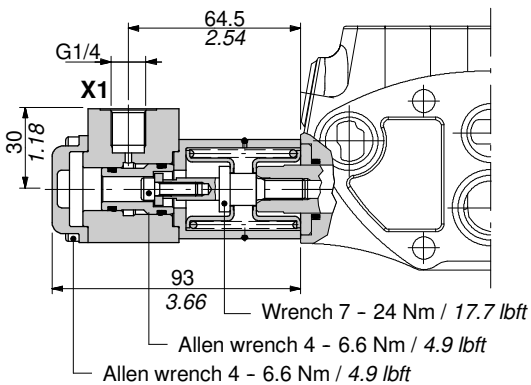

Operating features

Pilot pressure ..... : min. 50 bar / 725 psi  
max. 315 bar / 4600 psi

Kit 8IJ3

With return in neutral position from positions 1 and 2.

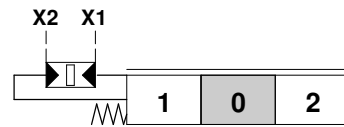
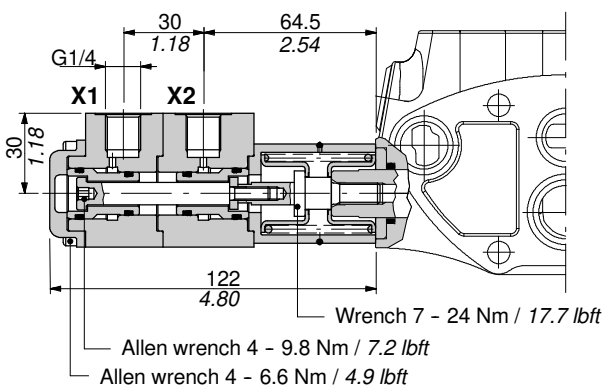

Operating features

Pilot pressure ..... : min. 50 bar / 725 psi  
max. 315 bar / 4600 psi

**8MHE3 kit: with spring return in neutral position and spool positioning ON/OFF signal**

This module supplies two different ON/OFF signals, related to the direction of the spool.

It has two separate contacts which can be normally open or normally closed.

It can be used with standard spools and working section (working section kit without ring on side “A”)

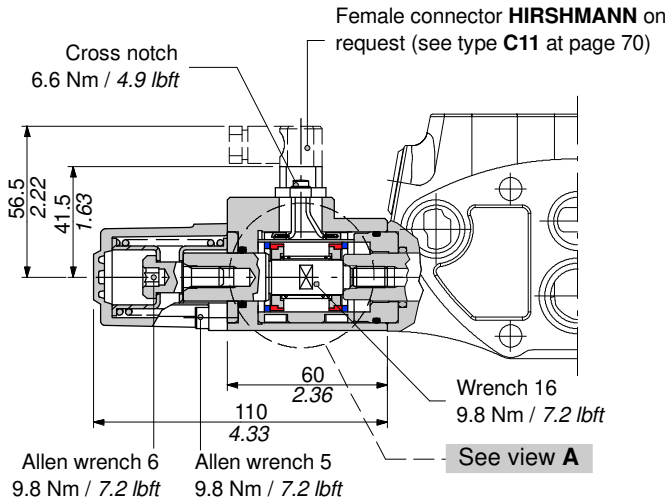

**Connector wiring**

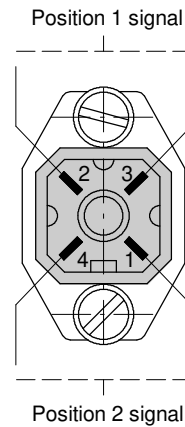

**Operating features**

- Power supply range : 12 / 24 VDC
- Max. output current . : 500 mA
- Weather protection . : IP65

**8MHE3(NC) kit**

Configuration with normally closed circuit

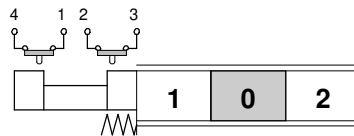

**View A**

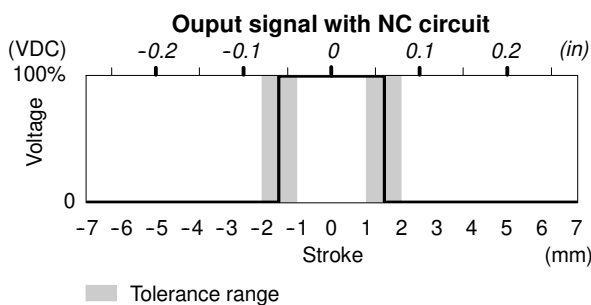
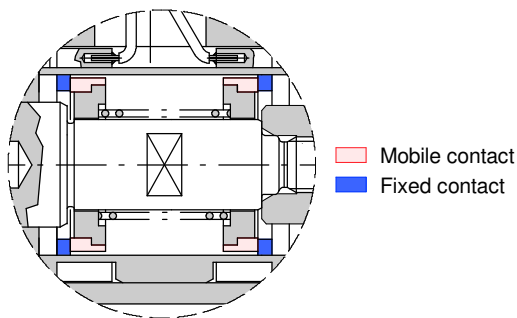

**8MHE3(NO) kit**

Configuration with normally open circuit

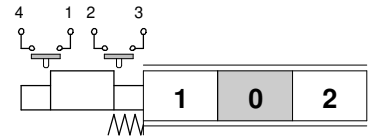

**View A**

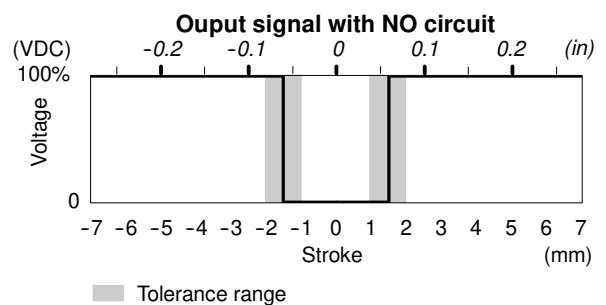
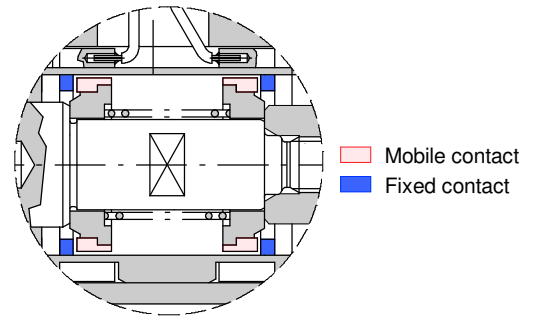

“A” side spool positioners

With detent and spring return to neutral position from either directions

9B kit

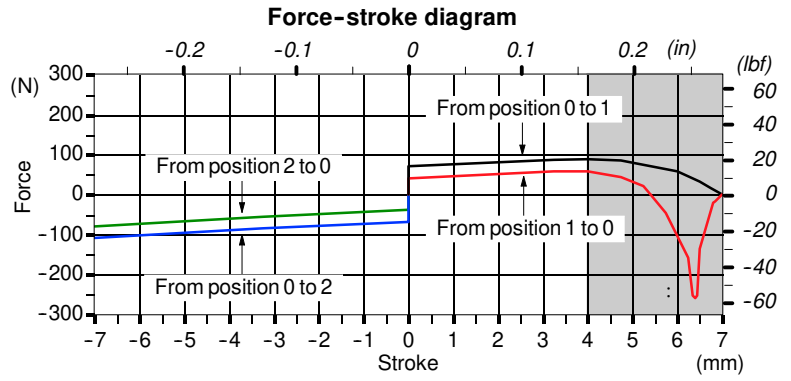
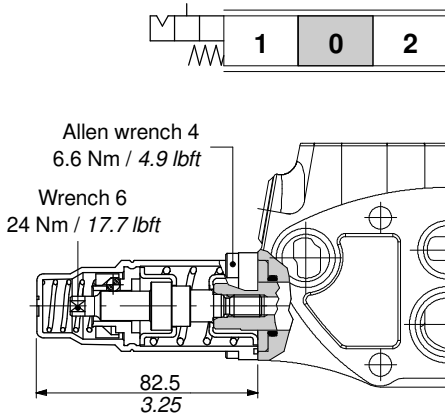

10B kit

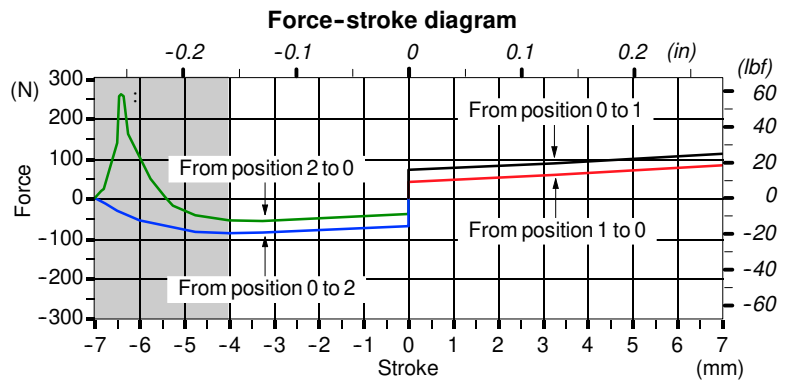
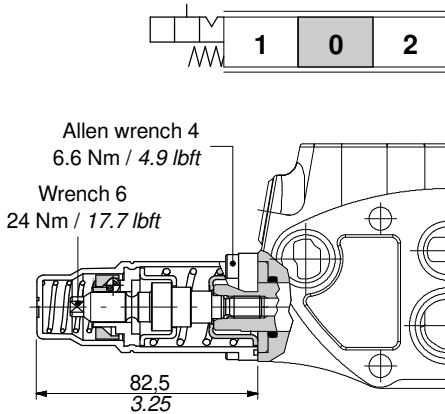

Kit 11B

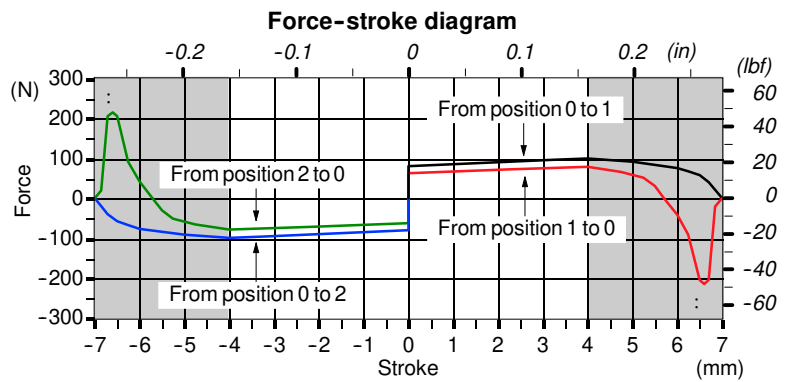
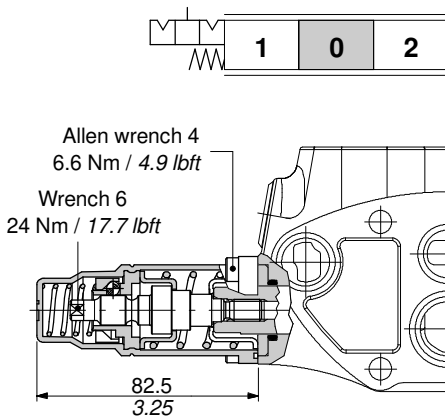

"A" side spool positioners

With detent

11 kit

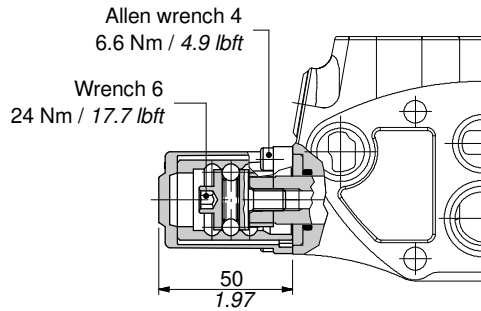
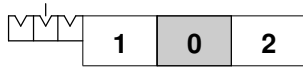

Operating features

Unlocking force ..... : 300 N ±15%

15 kit

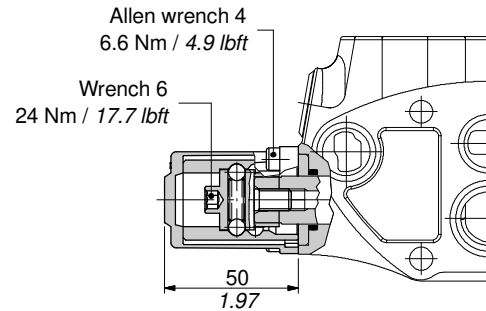
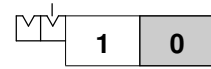

Operating features

Unlocking force ..... : 300 N ±15%

8EP3 ON/OFF electro-pneumatic control

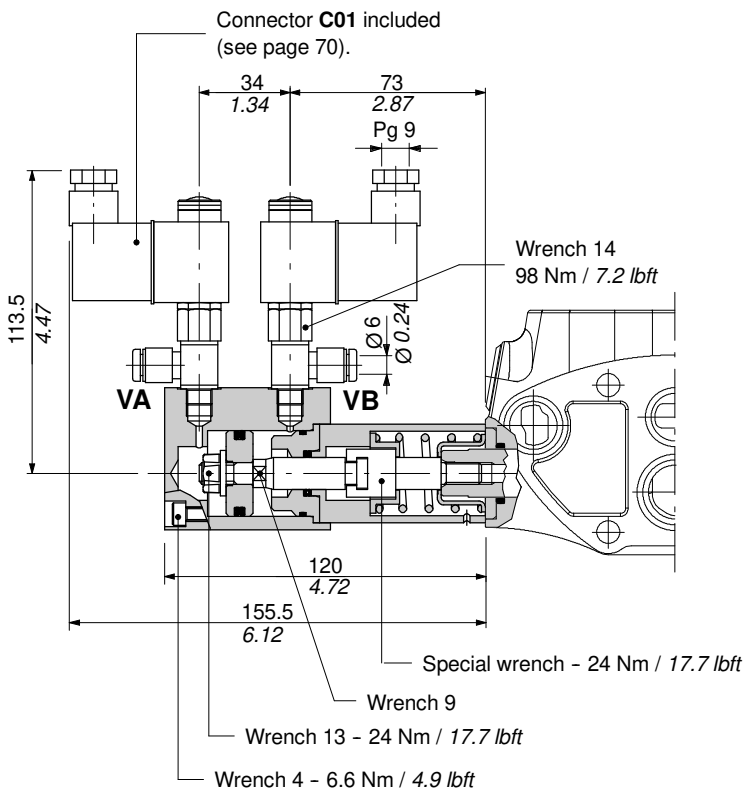

Scheme

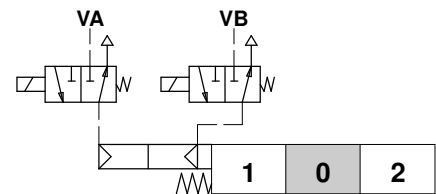

Scheme ISO 1219

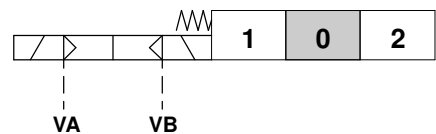

Operating features

Pilot pressure ..... : min. 6 bar - 87 psi  
 : max. 10 bar - 145 psi\*

Solenoid operating features

Nominal voltage tolerance ..... : ±10%  
 Power rating ..... : 8 W  
 Duty cycle ..... : 100%

Pneumatic solenoid valves codes (with connector)

CODE	DESCRIPTION
2X4001012	Nominal voltage 12VDC
2X4001024	Nominal voltage 24VDC

NOTE (\*) - It's available on request with P max. = 15 bar - 218 psi.

"A" side spool positioner

8ED3 kit

ON/OFF electro-hydraulic control with external pilot and drain.

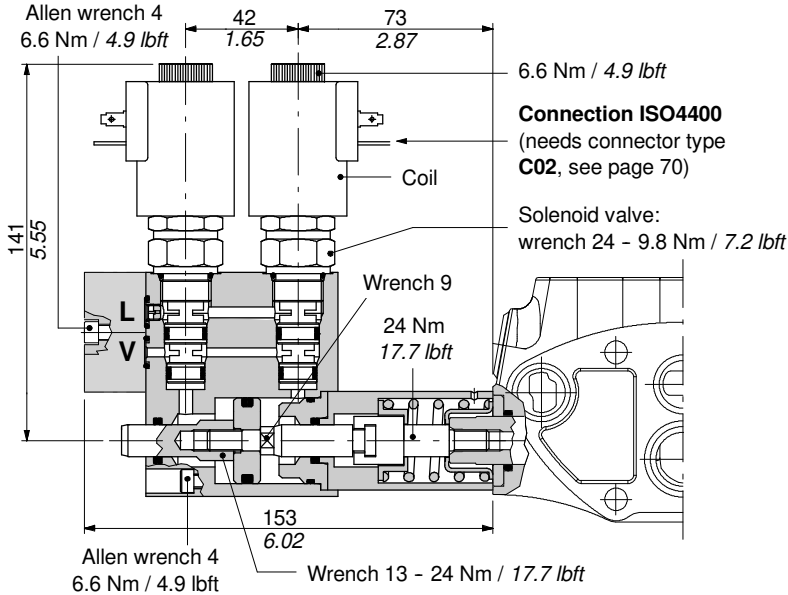

Detailed scheme

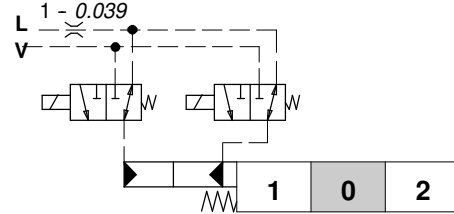

Scheme ISO 1219

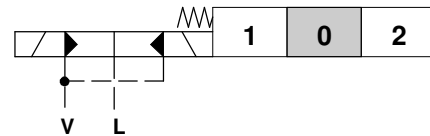

Operating features

Pilot pressure ..... : min. 10 bar / 145 psi  
 : max. 50 bar / 725 psi  
 Max backpressure on drain L ..... : 25 bar / 360 psi

Solenoid operating features

Nominal voltage ..... : 12 VDC / 24 VDC  
 Power rating ..... : 21 W  
 Duty cycle ..... : 100%

Ordering codes

CODE	DESCRIPTION
2S0EJ08002013	3-way solenoid valves
2X4350012	12VDC coil
2X4350024	24VDC coil

Collector kit for external pilot and drain

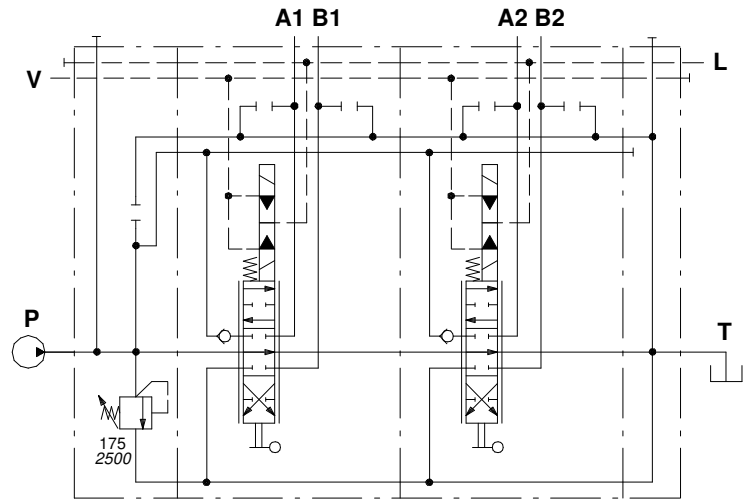
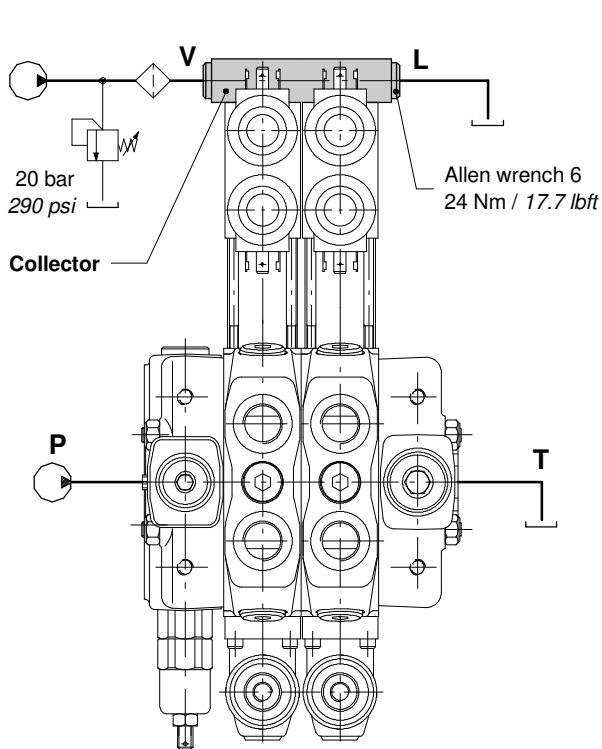

Ordering codes (BSP thread)

TYPE	CODE	DESCRIPTION
KE1S0	5KE1S00030	Kit for 1 section
KE2S0	5KE2S01330	Kit for 2 sections
KE3S0	5KE3S01330	Kit for 3 sections
KE4S0	5KE4S01330	Kit for 4 sections
KE5S0	5KE5S01330	Kit for 5 sections
KE6S0	5KE6S01330	Kit for 6 sections
KE7S0	5KE7S01330	Kit for 7 sections
KE8S0	5KE8S01330	Kit for 8 sections

Description example:

SD8/2/AC(YG3-175)/18ED3L/18ED3L/RC-KE2S0-24VDC

Collector kit with pilot and drain lines

The kit consists of a collector with VRP pressure reducing valve and relative pipes.

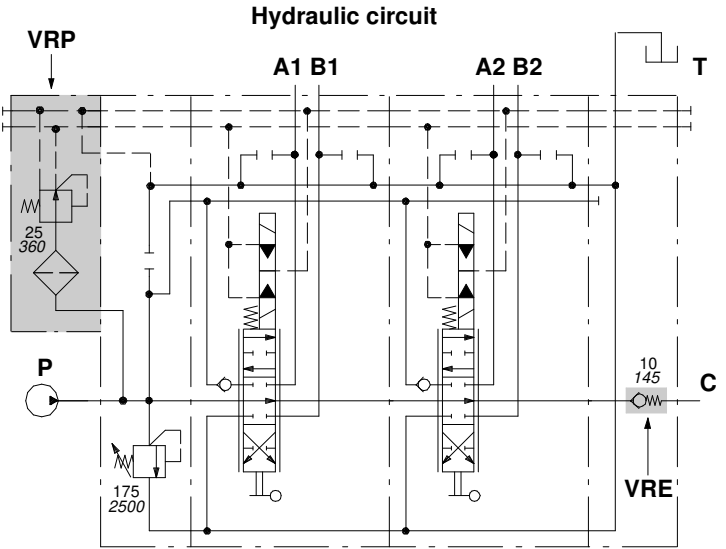
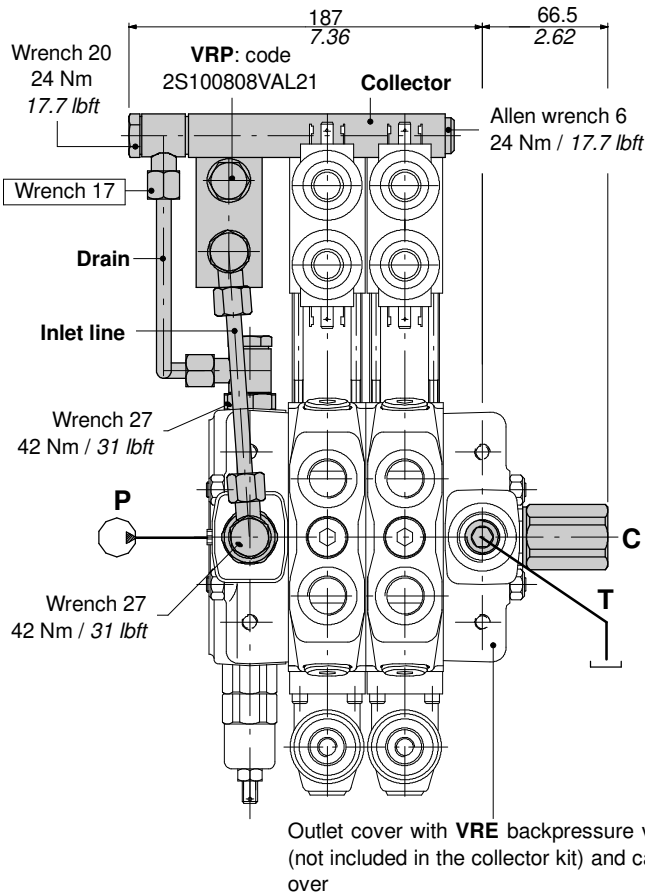

VRP valve operating features

- Outlet pressure ..... : 25 bar / 363 psi
- Max. flow ..... : 8 l/min
- Filtering ..... : 80 μ

Ordering codes (BSP thread)

TYPE	CODE	DESCRIPTION
KE1R3	5KE1R31330	Kit for 1 section
KE2R3	5KE2R31330	Kit for 2 sections
KE3R3	5KE3R31330	Kit for 3 sections
KE4R3	5KE4R31330	Kit for 4 sections
KE5R3	5KE5R31330	Kit for 5 sections
KE6R3	5KE6R31330	Kit for 6 sections
KE7R3	5KE7R31330	Kit for 7 sections
KE8R3	5KE8R31330	Kit for 8 sections

Description example:

SD8/2/AC(YG3-175)/18ED3L/18ED3L/RV-KE2R3-24VDC

Description type for outlet cover with VRE valve.

VRE backpressure valve

Valve is assembled on flow through passage of outlet cover; it's necessary to provides pilot pressure to the actuator.

RV complete outlet cover, code: 613300121.

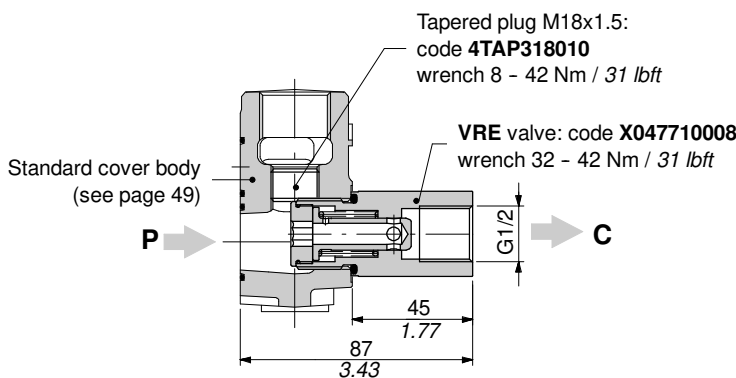

Pressure drop P→C

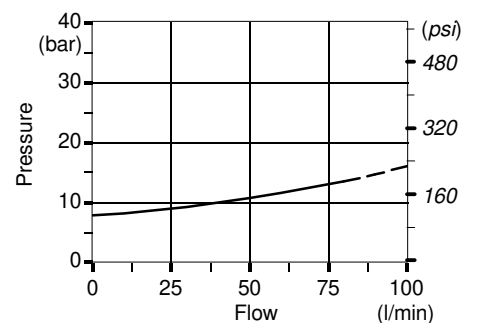

“A” side spool positioners

8PF pneumatic proportional kit

It can be used with standard spools and body; body kit without spool seals on side “A” (O-ring seal on spool in the drawing is part of positioner).

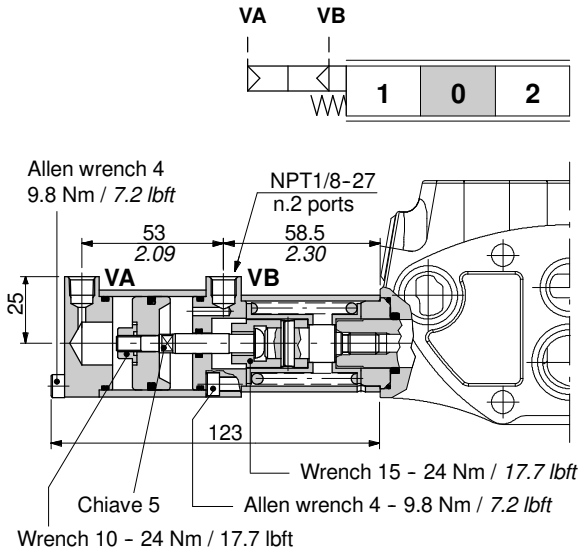

Available section kits

TYPE	CODE
Q/8PF	5EL108301B
P/8PF	5EL108300D

NOTE: Codes are referred to **BSP** thread.

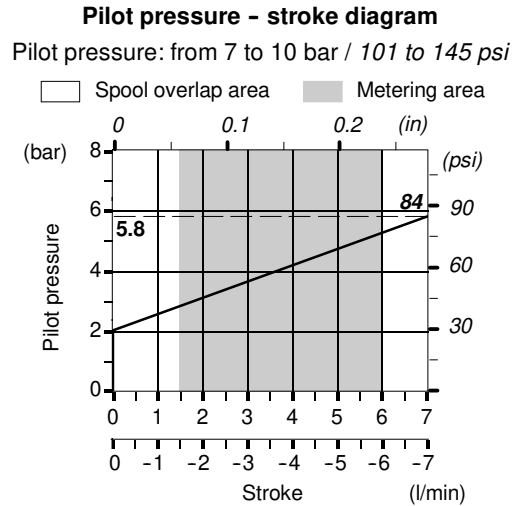

With microswitch type 8MG3(NO)

With spring return in neutral position and microswitch operated in both directions.

Also available **8MG1(NO)** configuration, code **5V08108060** (microswitch operated in position 1) and **8MG2(NO)** configuration, code **5V08108070** (microswitch operated in position 2); dimensions are the same of 8MG3 configuration.

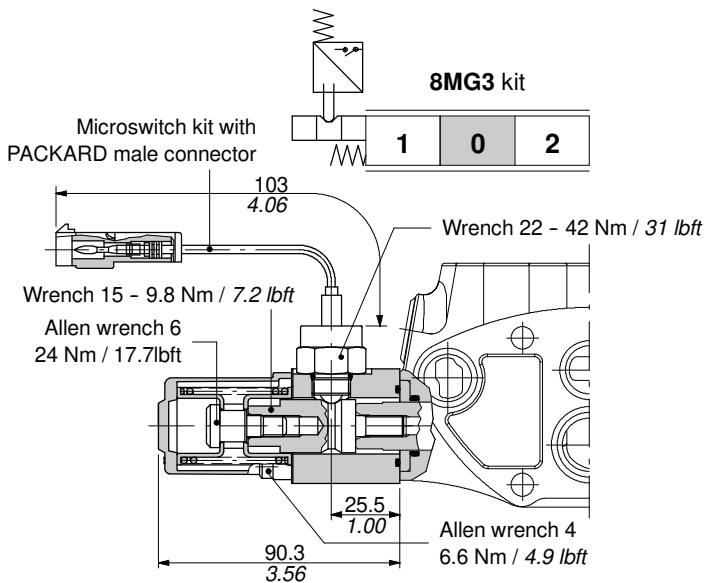

Other configurations

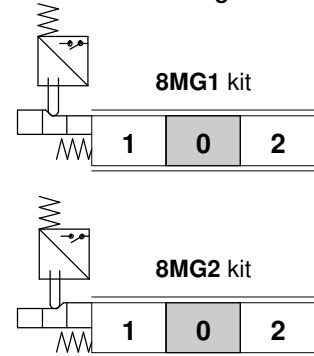

Microswitches ordering codes

The kit consisting of microswitch and connector, can be ordered separately (normally closed NC version is available on request).

CODE	DESCRIPTION
4MIC730	Normally <b>open</b> (NO) microswitch kit with PACKARD <b>male</b> connector: needs <b>C07</b> female connector
4MIC740	Normally <b>closed</b> (NC) microswitch kit with PACKARD <b>female</b> connector: needs <b>C17</b> male connector

For connection see page 70.

Microswitch operating features

Mechanical life	: 5x10 <sup>5</sup> operations
Electrical life (resistive load)	: 10 <sup>5</sup> operations - 7A / 13,5VDC
	: 5x10 <sup>4</sup> operations - 10A / 12VDC

Lever control

L type

Aluminium lever pivot box with protective rubber bellow; it can be rotated 180° (configuration L180).

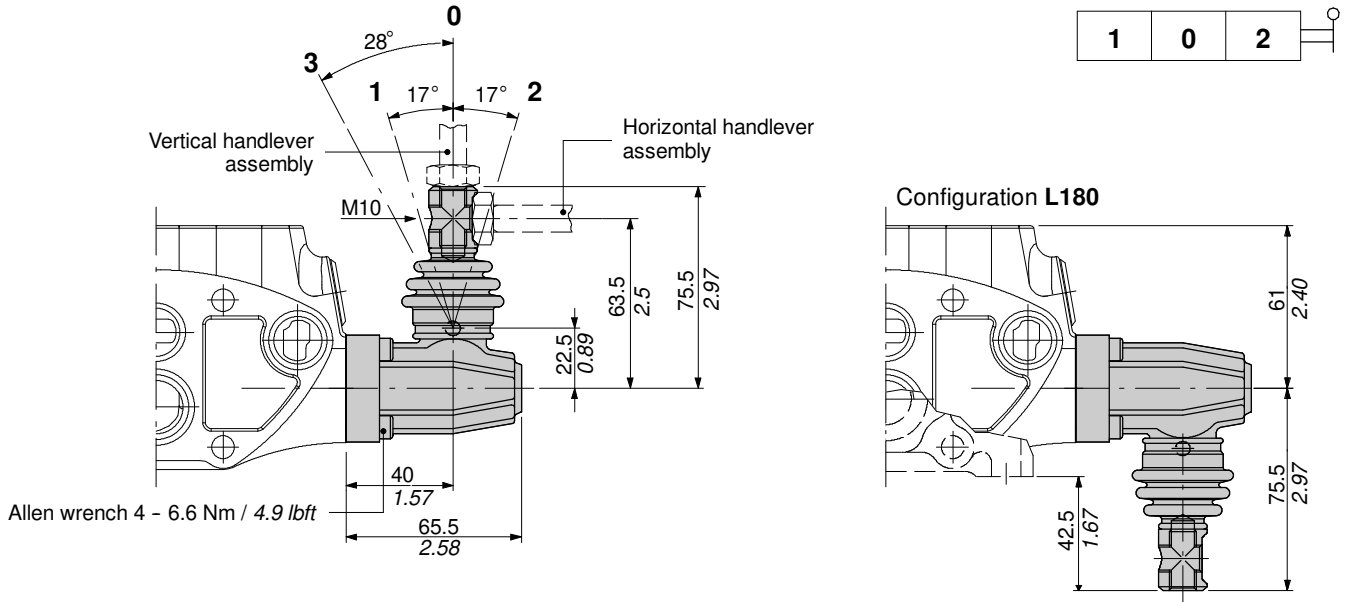

LF3 type

Zama (zinc alloy) lever pivot box with protective rubber bellow; it's complete of two screws for spool stroke adjusting. It can be rotated 180° (configuration LF3180).

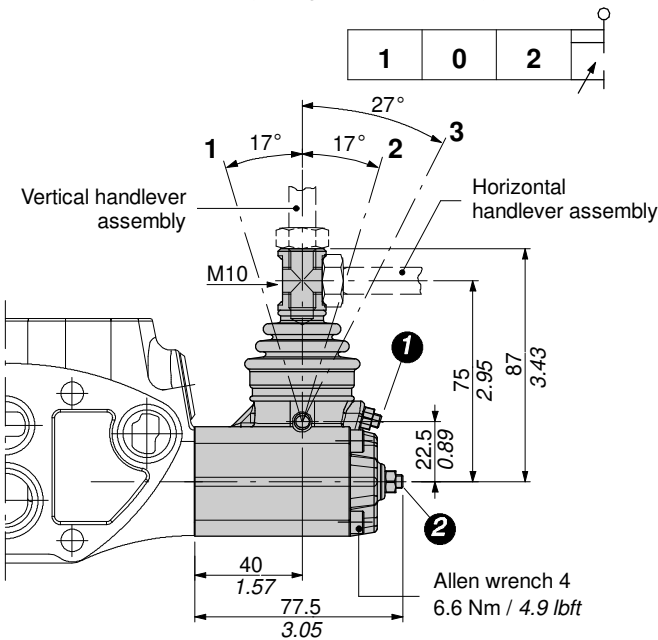

- ① Stroke end screw for position 2: allen wrench 2.5  
Fixing nut: wrench 8 - 6.6 Nm / 4.9 lbf
- ② Stroke end screw for position 1: allen wrench 2.5  
Fixing nut: wrench 8 - 6.6 Nm / 4.9 lbf

LB type

Steel and cast iron construction.



Execution LB4

Pivot placed above on the right

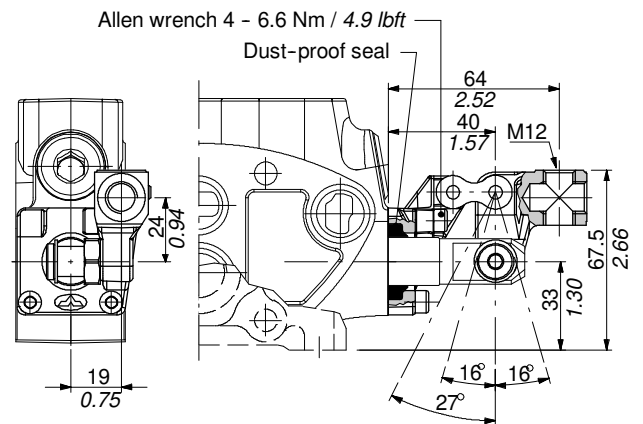

NOTE - The pivot can be assembled placed down on the left (execution LB1) or can be rotated 90°; in this case, the interference with other lever controls must be checked. For further information please contact Customer Service.

"B" side options

Controls prearrangement

SLP type

Mechanical control with dust-proof plate kit.

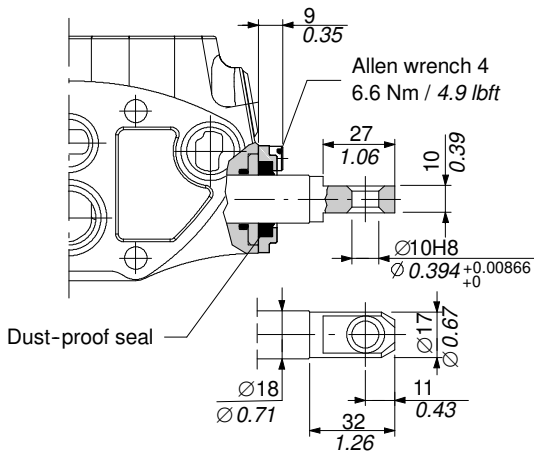
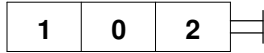

SLCY type

Protection cap usable with pneumatic 8PF, electro-pneumatic 8EP3, and electro-hydraulic 8ED3 spool positioners.

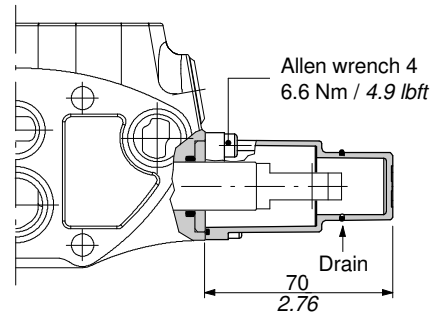
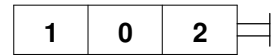

TQ cable remote control kit

Waterproof cap prearranged for remote control with flexible cable.

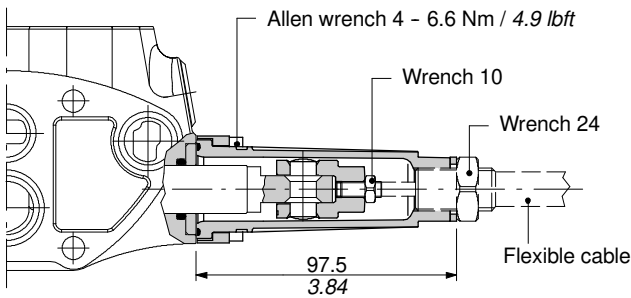
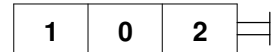

NOTE - For further information about remote cable control, require related documentation.

Example of cable control

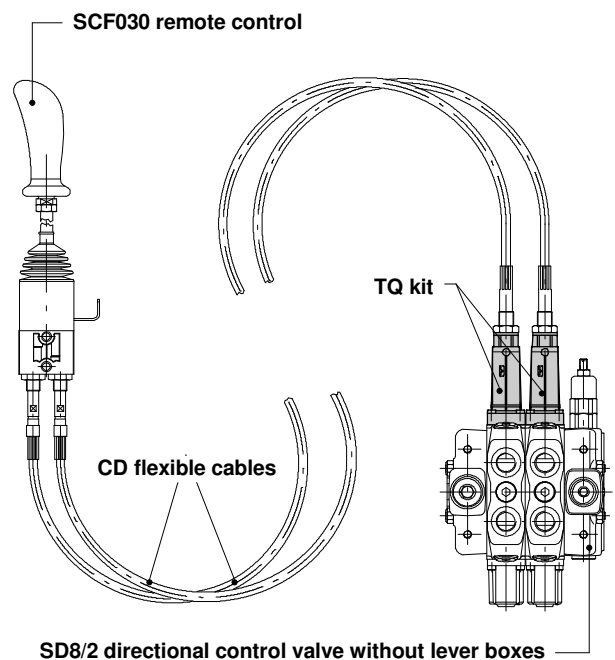

LCB joystick

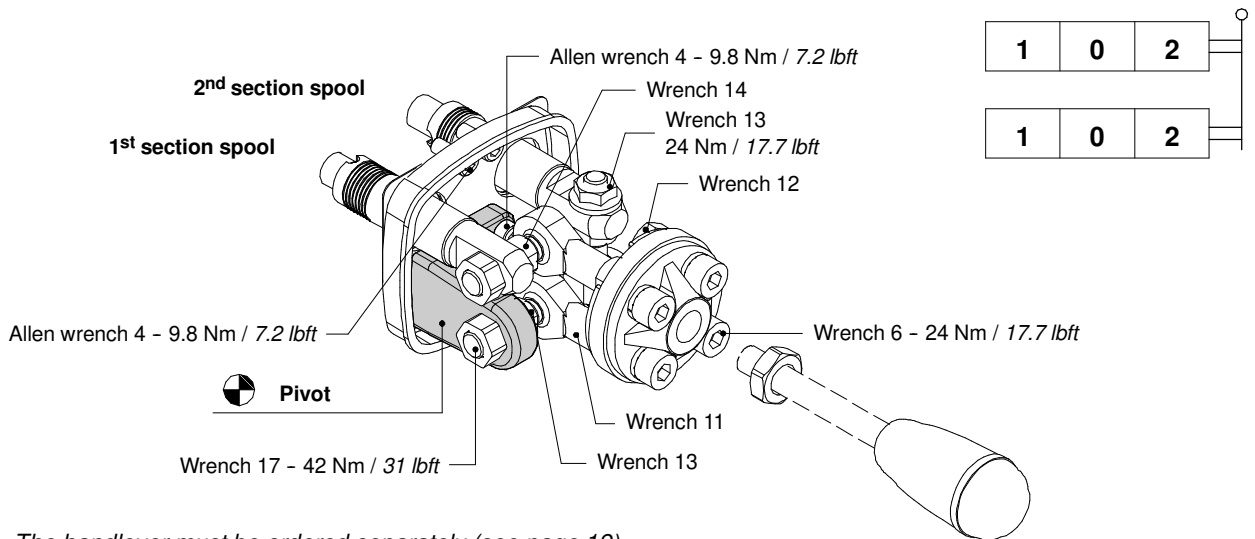

NOTE - The handlever must be ordered separately (see page 19).

Dimensions and movement scheme

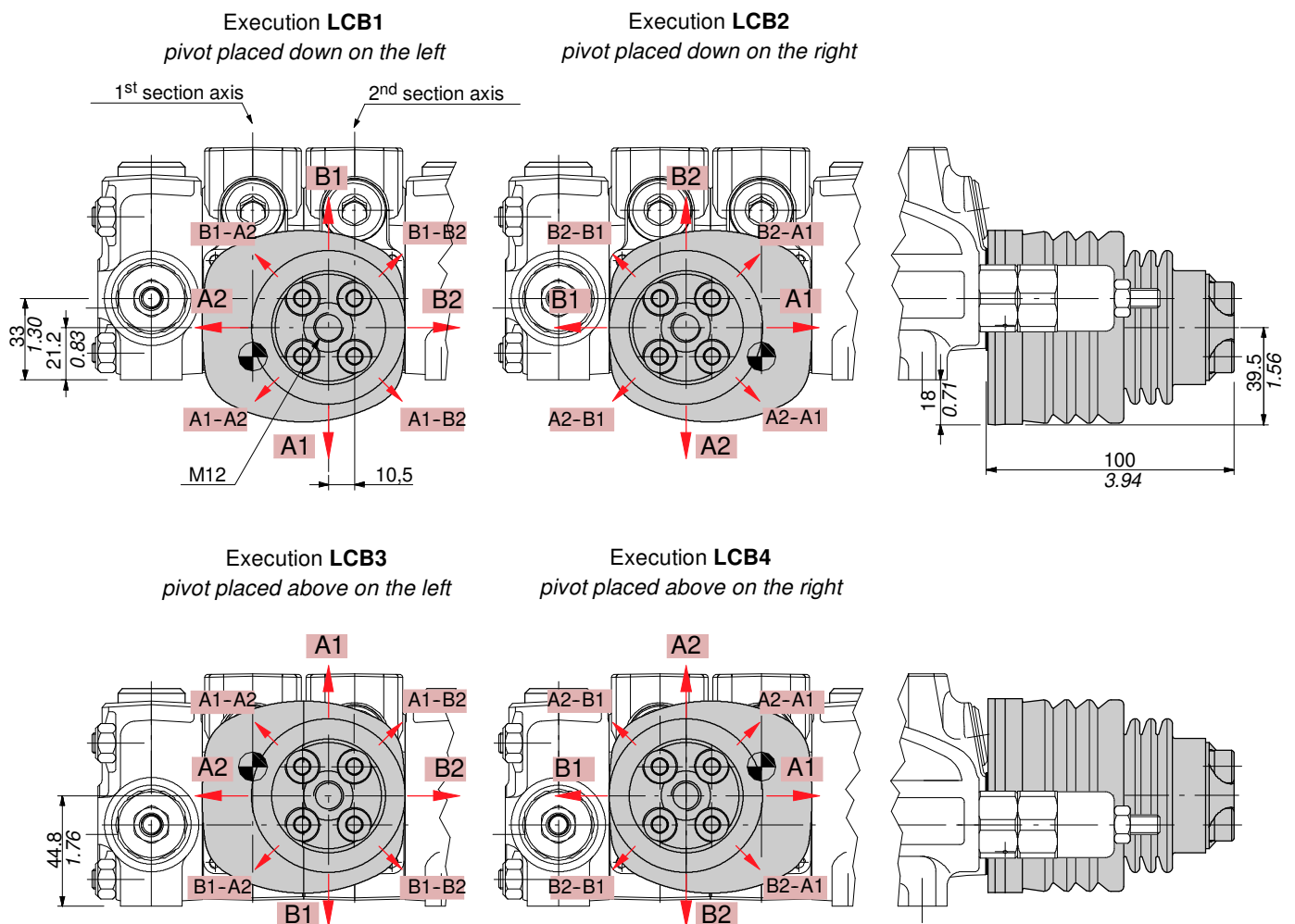

NOTE - Due to limited space in case of LCB3 or LCB4 configuration the assembly of ports service relief valves is not possible.

Complete controls

Proportional hydraulic kit:

Type 8IM code: 5IDR208300

It can be used on SD8 directional valve with spools type 1CSG code 3CU2310250, 1M code 3CU2310420 (see page 18) and standard working section (working section kit without seals on spool).

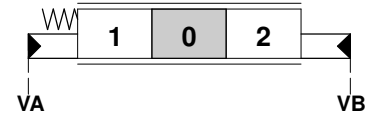
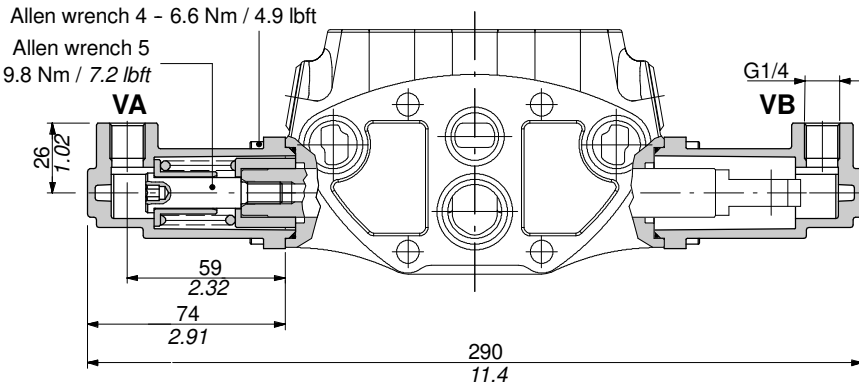

Available working section kits

TYPE	CODE
Q/IM	5EL108301A
P/IM	5EL108300A

NOTE: Codes are referred to BSP thread.

Type 8IMF3 code: 5IDR208220

It's an execution with screws for spool stroke adjusting: with SD8 directional valve use 1CSG and 1M spools, with DLS8 directional valve use standard spool (page 43).

Available working section kits are the same of 8IM control.

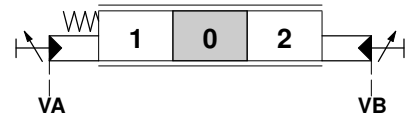
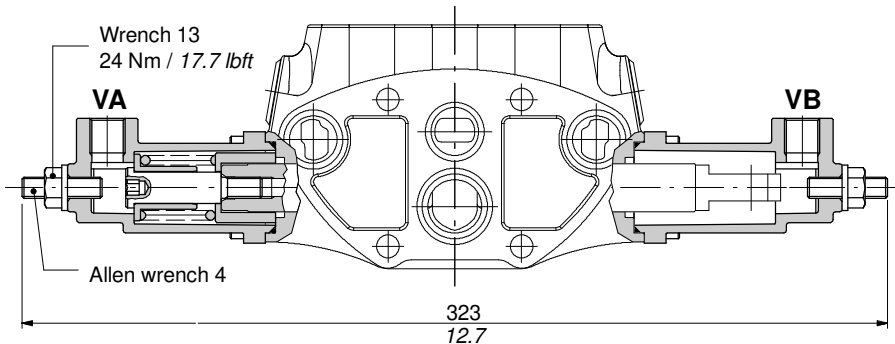

Performance data

Pilot pressure - stroke diagram

Max. pilot pressure 30 bar - 435 psi.

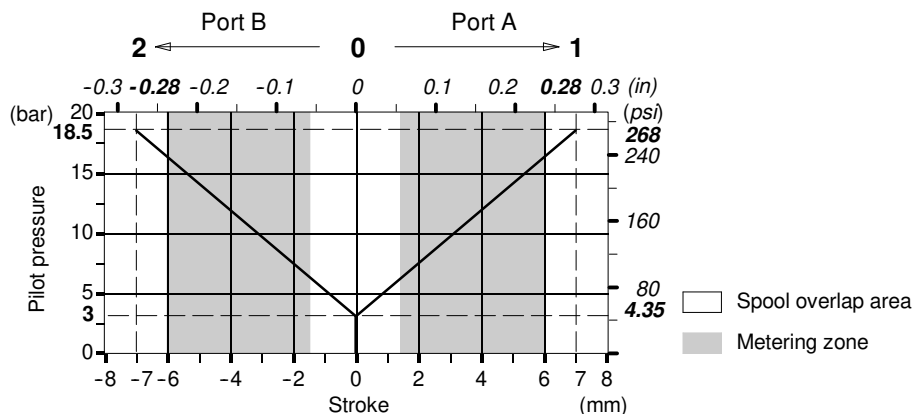

Proportional hydraulic kit:

Connection example

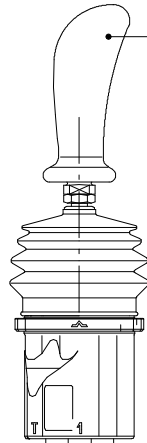
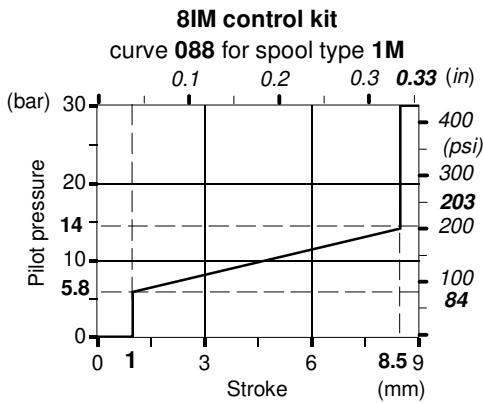
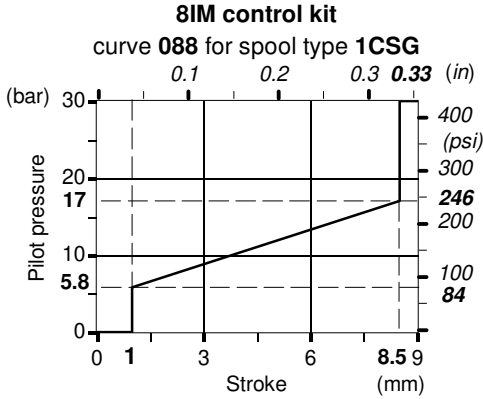

Hydraulic pilot control valve series SV01 with curve 088 or 089.

Hydraulic circuit

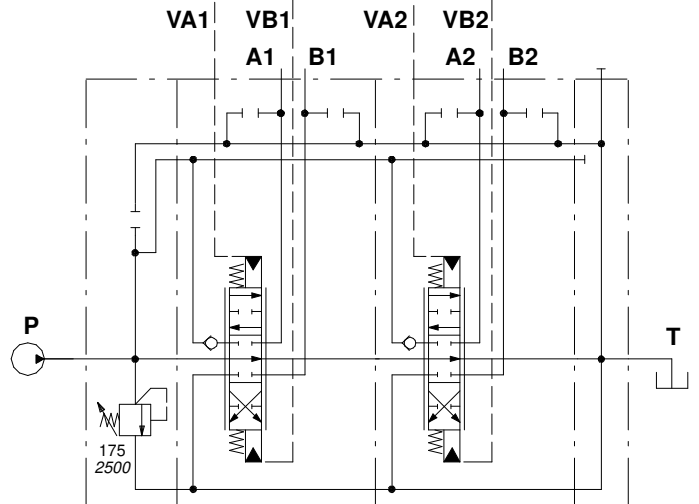
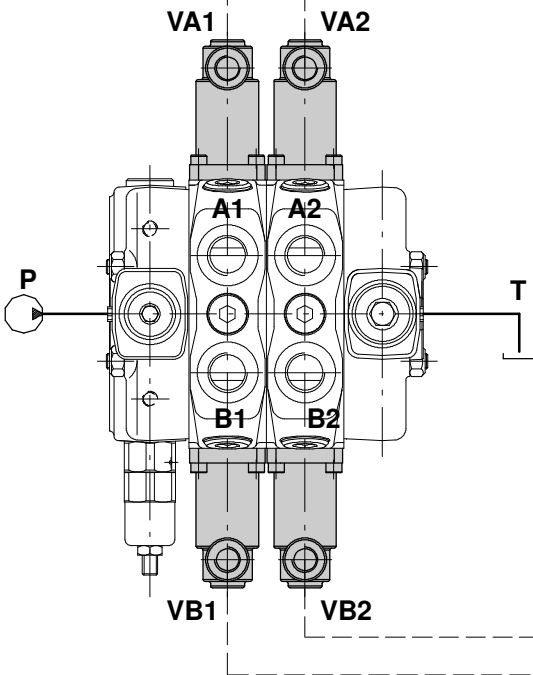
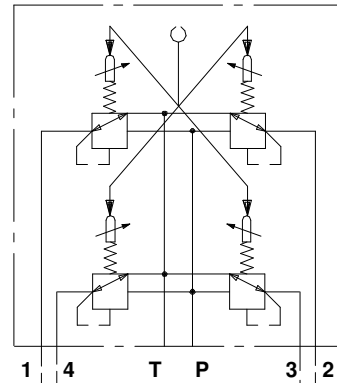

Ex:  
SD8/2/AC(YG3-175)/1CSG8IM/1CSG8IM/RC+  
SV01-B/01W-088MA-088MA-088MA-088MA

## Complete controls

### 8ES solenoid control

Solenoid direct control with spring return to neutral position; it needs special spools and standard working section body (body kit without seals on spool).

#### Description example:

EL SD8 / P - 1 8ES3 P 1 (G3 - 100) - 24VDC

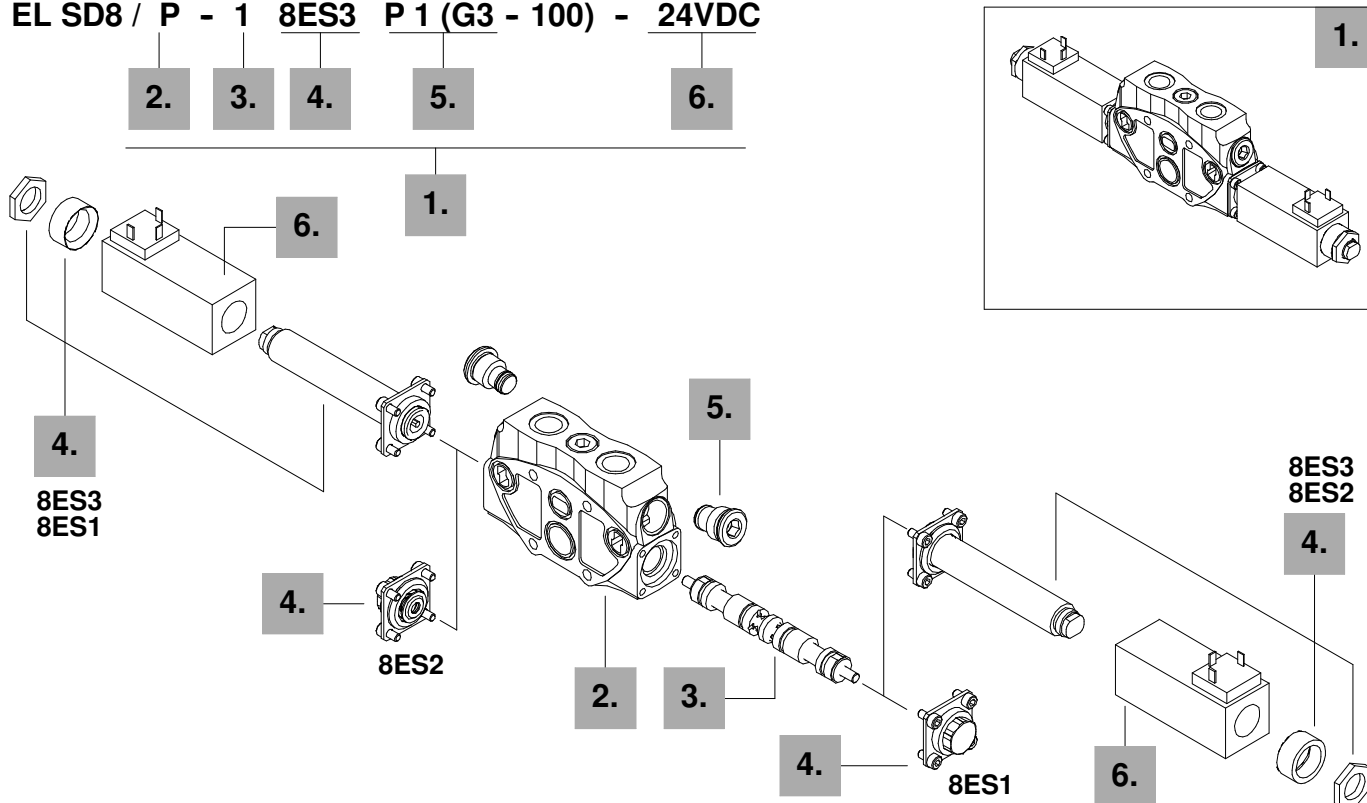

#### 1. Complete working sections \*

TYPE	CODE	DESCRIPTION
Q-18ES3-12VDC	613151005	Parallel circuit, double acting spool with double acting solenoid control
P-18ES3-12VDC	613101017	As previous with port valves prearrangement

#### 2. Working section kits \*

TYPE	CODE	DESCRIPTION
Q/IM-ES	5EL108301A	Parallel circuit
P/IM-ES	5EL108300A	As previous with port valves prearrangement

#### 3. Spools

TYPE	CODE	DESCRIPTION
1(ES3)	3CU2310020	Double acting, 3 positions, with A and B closed in neutral position
2(ES3)	3CU2325020	Double acting, 3 positions, with A and B open to tank in neutral position

#### 4. Control kit

TYPE	CODE	DESCRIPTION
8ES1	5V08018	P→A, with spring return to neutral position
8ES2	5V08018	P→B, with spring return to neutral position
8ES3	5V08019	Double acting with spring return to neutral pos.

#### 5. Port relief valves

For codes please refer to page 21.

#### 6. Coils

TYPE	CODE	DESCRIPTION
12VDC	4SOL714112	Nominal voltage 12VDC
24VDC	4SOL714124	Nominal voltage 24VDC

NOTE (\*) - Codes are referred to **BSP** thread.

8ES solenoid control

Electric wiring example

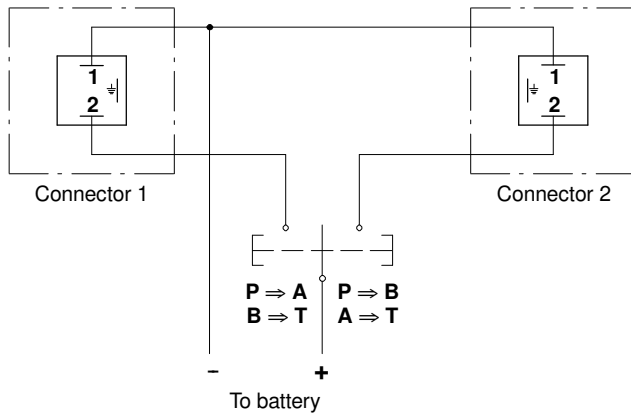

8ES3 kit  
double acting



8ES1 kit  
single acting on A

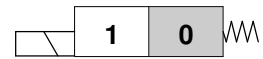

8ES2 kit  
single acting on B

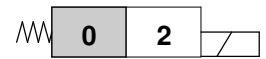

Operating features

Internal leakage A(B)→T  
( $\Delta p = 100 \text{ bar} - 1450 \text{ psi} / T = 40^\circ\text{C}$ ) :  $10 \text{ cm}^3/\text{min} - 0.61 \text{ in}^3/\text{min}$

Coil operating features

Nominal voltage tolerance :  $\pm 10\%$   
Power rating : 48 W  
Coil insulation : class H  
Duty cycle : 100%

Operating condition diagram

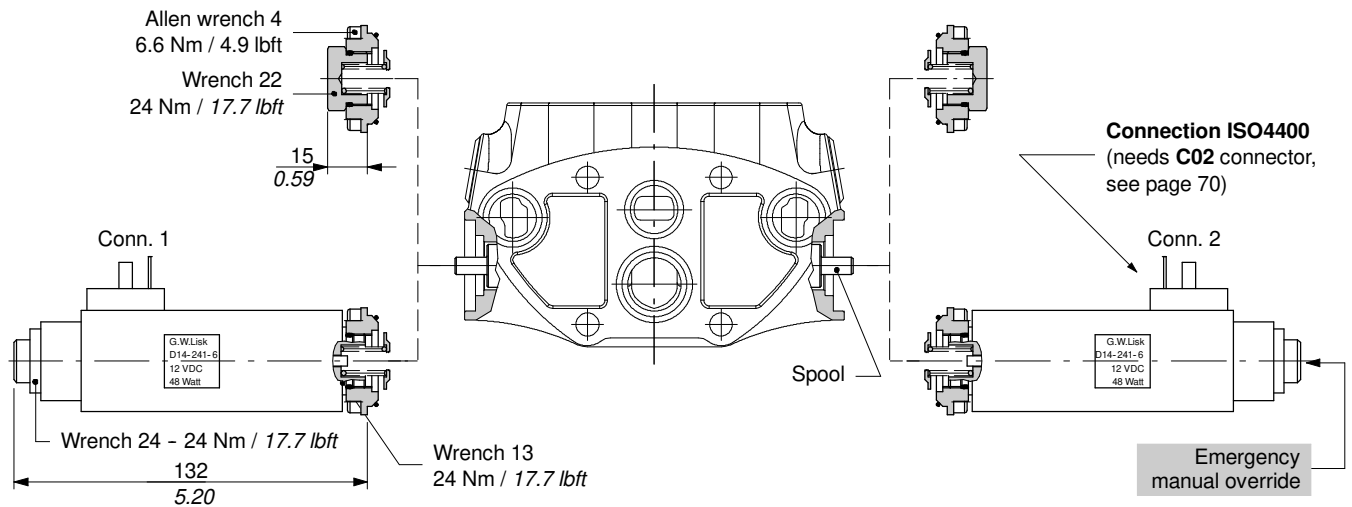
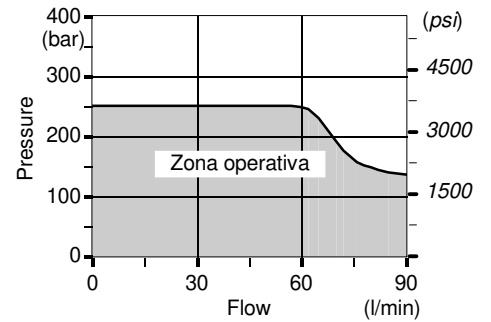

Anti-shock valves

**P 1 ( G 3 - 100 )**

Pressure setting in bar.

Spring type (1, 3, 4).

Adjustment type (G, H).

1 mounted on port A.

2 mounted on port B.

3 mounted on ports A and B.

**P** standard type (with spring type 3, 4)

**PM,PR** for low setting (only with spring type 1)

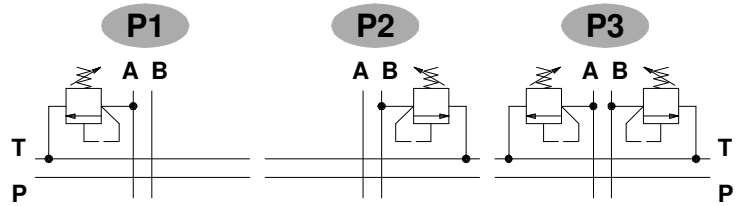

Valve type

Type P

Wrench 22 - 42 Nm / 31 lbft

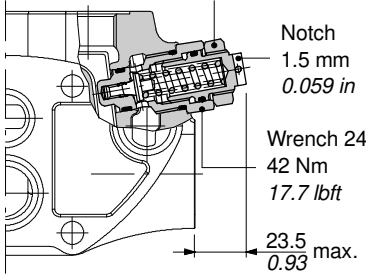

Type PM, PR

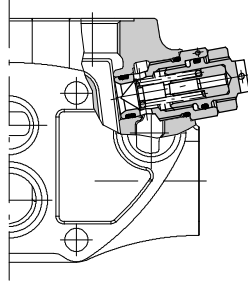

Adjustment type

G: with screw

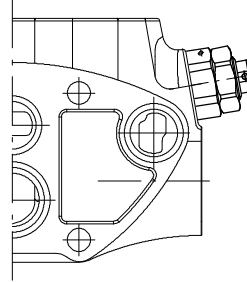

H: valve set and locked

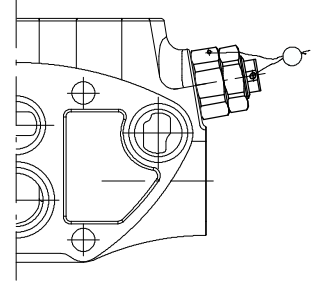

Performance data

Type PR, spring nr.1 : standard setting 30 bar / 435 psi

Type PM, spring nr.1 : standard setting 50 bar / 725 psi

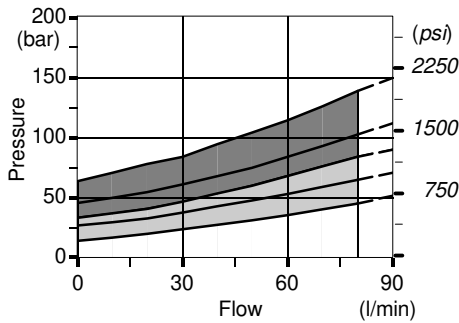

Type P, spring nr.3 (blue band)

Standard setting: 100 bar / 1450 psi

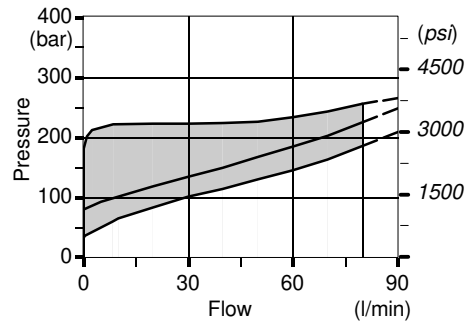

Type P, spring nr.4 (red band)

Standard setting: 200 bar / 2900 psi

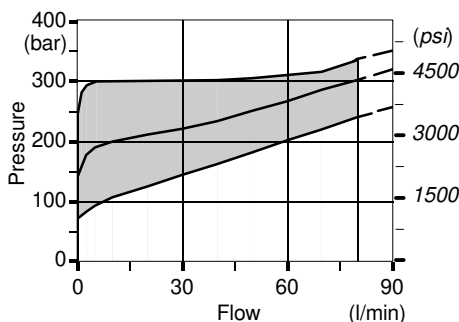

Time response

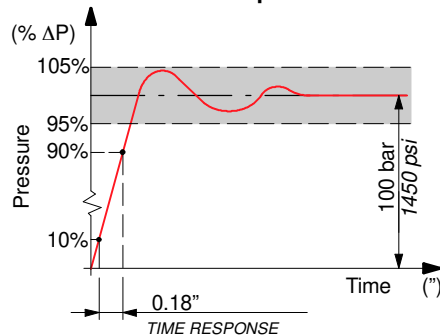

Anti-shock and anti-cavitation valves

**U 1 ( G 3 - 100 )**

- Pressure setting in bar.
- Spring type (2, 3, 4).
- Adjusting type (G, H).
- 1 mounted on port A.
- 2 mounted on port B.
- 3 mounted on ports A and B.

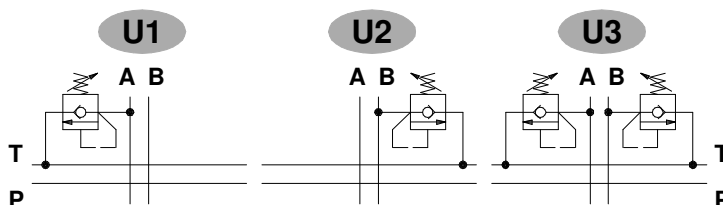

Adjusting type

**G:** with screw

**H:** valve set and locked

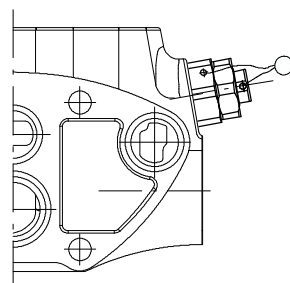
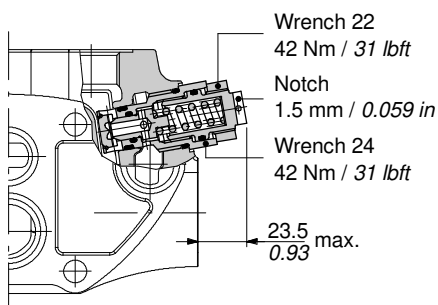

Performance data

**Spring nr.2 (green band)**

Standard setting: 63 bar / 900 psi

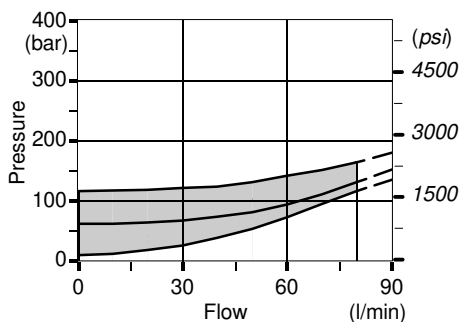

**Spring nr.3 (blue band)**

Standard setting: 100 bar / 1450 psi

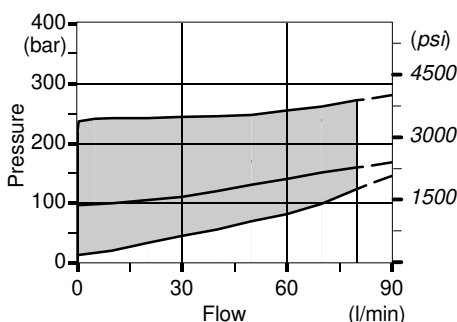

**Spring nr.4 (red band)**

Standard setting: 200 bar / 2900 psi

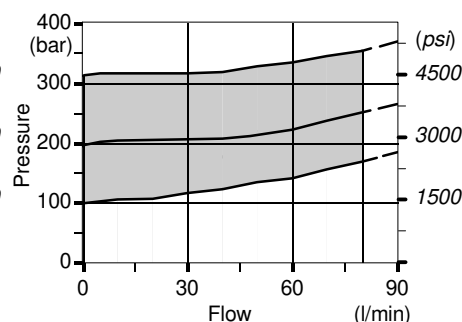

**Time response**

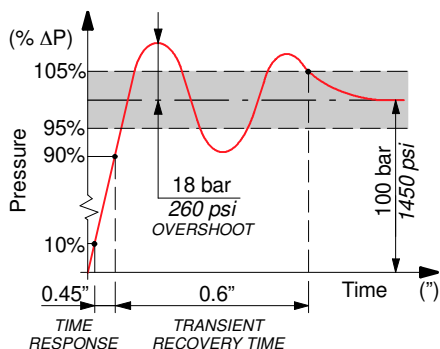

**Pressure drop**

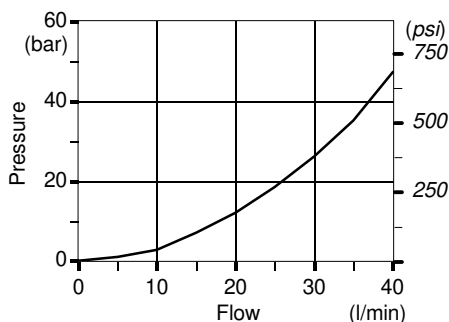

Anti-cavitation valves

C 1

- 1 mounted on port A.
- 2 mounted on port B.
- 3 mounted on port A and B.

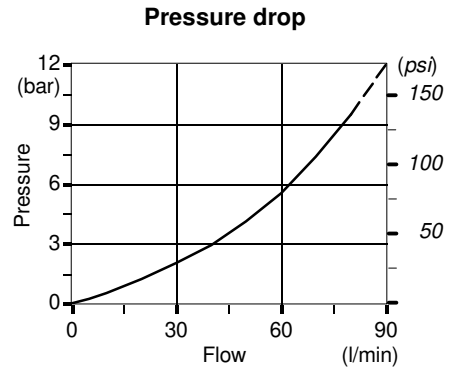
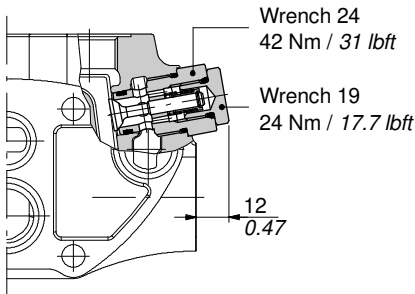
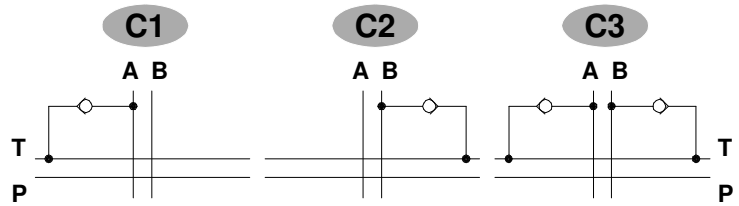

Valve blanking plug with tank connection

DST 1

- 1 mounted on port A.
- 2 mounted on port B.

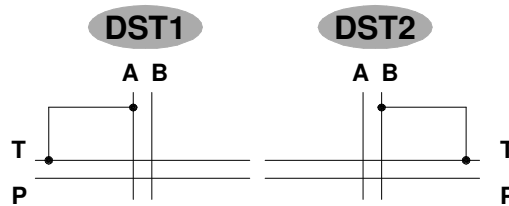
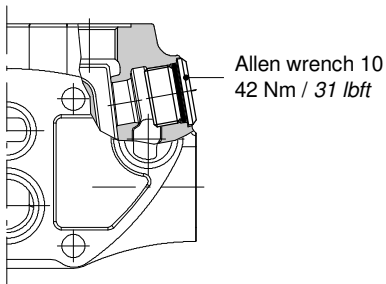

Valve blanking plug

P 1 T

- 1 mounted on port A.
- 2 mounted on port B.
- 3 mounted on ports A and B.

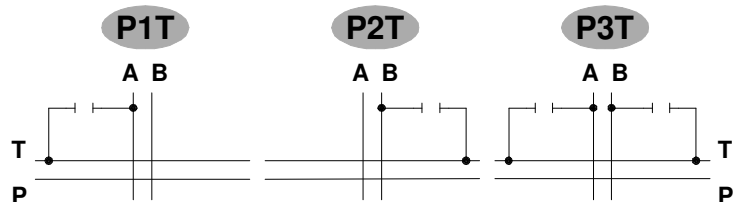
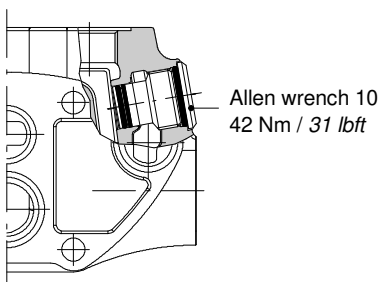

## Installation and maintenance

The SD8-DLS8 valves are assembled and tested as per the technical specification of this catalogue.

Before the final installation on your equipment, follow the below recommendations:

- the valves can be assembled in any position; in order to prevent working section deformation and spool sticking mount the products on a flat surface;
- in order to prevent the possibility of water entering the lever box and spool control kit, do not use high pressure wash down directly on the valve;
- prior to painting, ensure plastic port plugs are tightly in place.

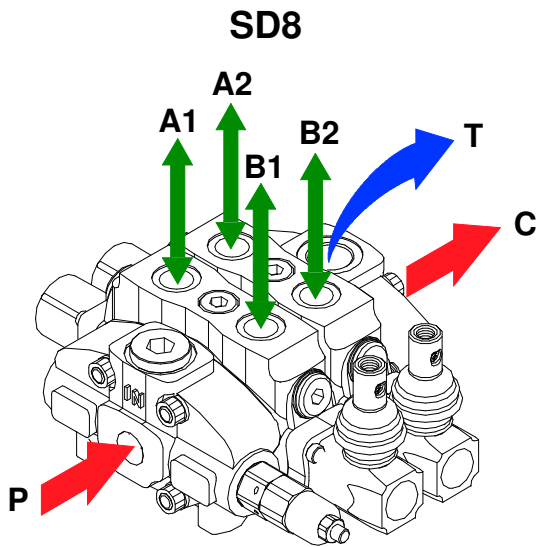

**Carry-over configuration**

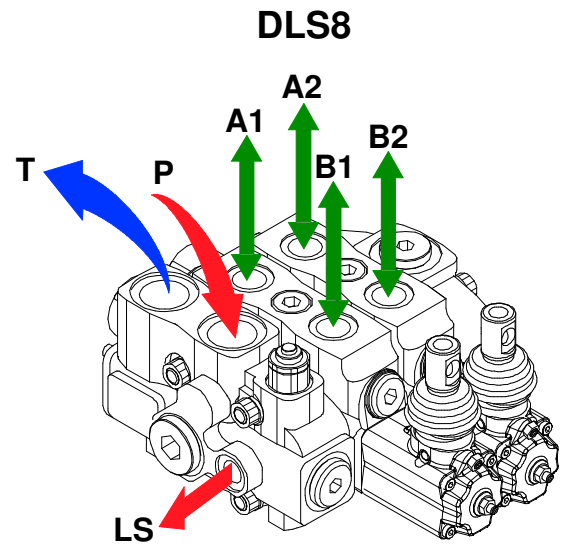

**AN inlet cover configuration**

### Fitting tightening torque - Nm / lbft

THREAD TYPE	port P	ports A and B	ports T and C	LS signal
BSP (ISO 228/1)	G 1/2	G 1/2	G 3/4	G 1/4
With O-Ring seal	50 / 36.9	50 / 36.9	70 / 51.6	20 / 14.7
With copper washer	60 / 44.3	60 / 44.3	70 / 51.6	25 / 18.4
With steel and rubber washer	60 / 44.3	60 / 44.3	70 / 51.6	16 / 11.8
UN-UNF (ISO 11926-1)	7/8-14 (SAE 10)	3/4-16 (SAE 8)	7/8-14 (SAE 10)	9/16-18 (SAE 6)
With O-Ring seal	90 / 66.4	60 / 44.3	90 / 66.4	30 / 22.1
METRIC (ISO 6149)	M22x1.5	M22x1.5	M27x2	M14x1.5
With O-Ring seal	60 / 44.3	60 / 44.3	100 / 73.7	35 / 25.8

NOTE - These torque are recommended. Assembly tightening torque depends on many factors, including lubrication, coating and surface finish. The manufacturer shall be consulted.

## Installation and maintenance

It's shown a section of SD8/2/AC(YG3-175)/18L/18L/RC directional valve.

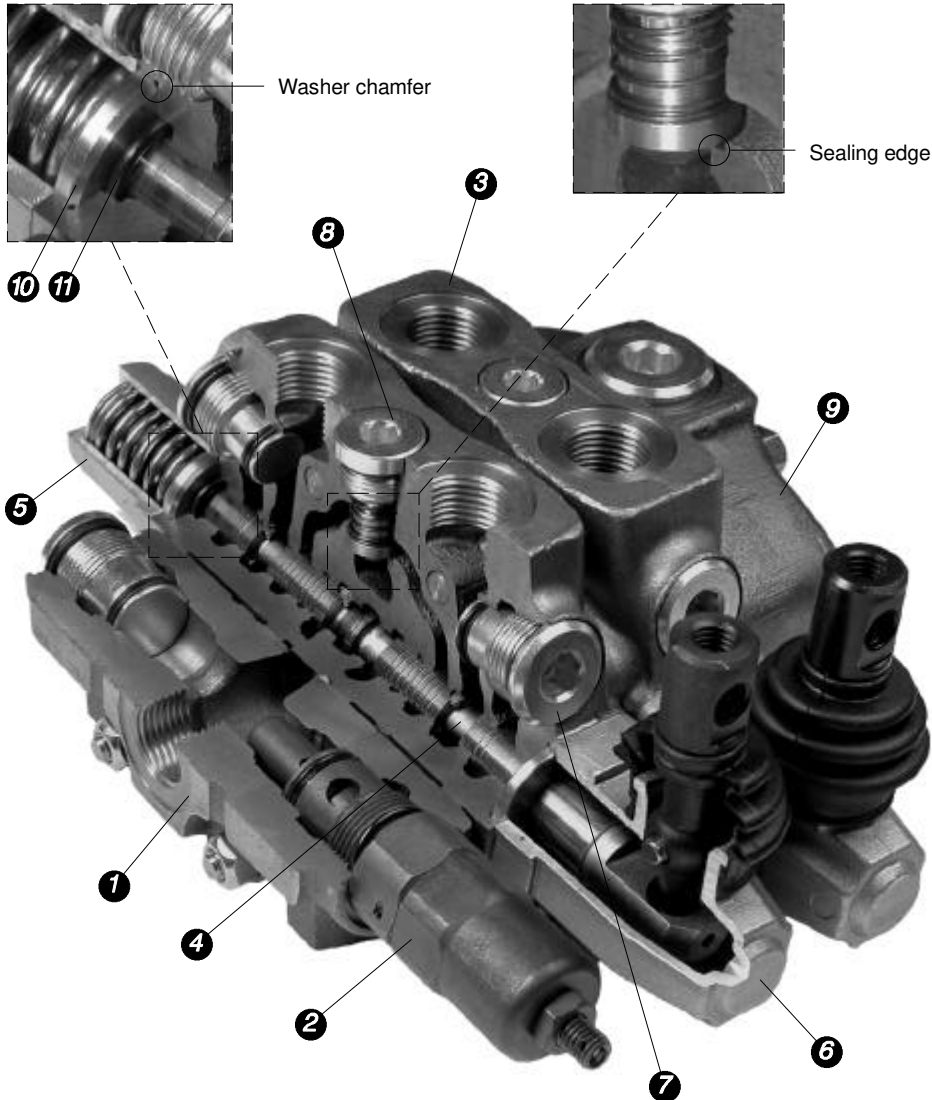

Callout
1) Inlet cover
2) Overpressure relief valve
3) Working section
4) Spool: <i>normally spools are interchangeable, verify the smoothness during the assembly</i>
5) "A" side spool positioner
6) Lever pivot box
7) Port relief valve prearrangement
8) Load check valve
9) Outlet cover
10) Holding O-Ring washer
11) O-Ring seal 18x2.5 code: 4GUA118025

NOTE - All moving parts inside cap, lever box and mechanical joystick are lubricated with synthetic base grease grade NLGI2

Malfunction	Cause	Remedy
External leakage pivot box lever or control kit side.	Worn spool seal due to mechanical actuation or high back pressure.	Locate the leakage and replace the seal. Check back pressure level.
Excessive internal leakage on A and B ports.	Increase clearance between spools and body due to high wear.	Replace the working section and check the oil contamination level.
Dropping load during transition while raising	High leakage on the load check valve.	Remove the load check valve and clean the seat, verifying it's not dented.
Inability to build pressure on A and B ports.	Pressure relief valve blocked open. Low pump pressure and flow.	Remove and clean or replace the valve. Check the pump and circuit.

Installation and maintenance

It's shown a section of DLS8/2/AM(G3-120)/6N8LF3/6N8LF3/RF directional valve.

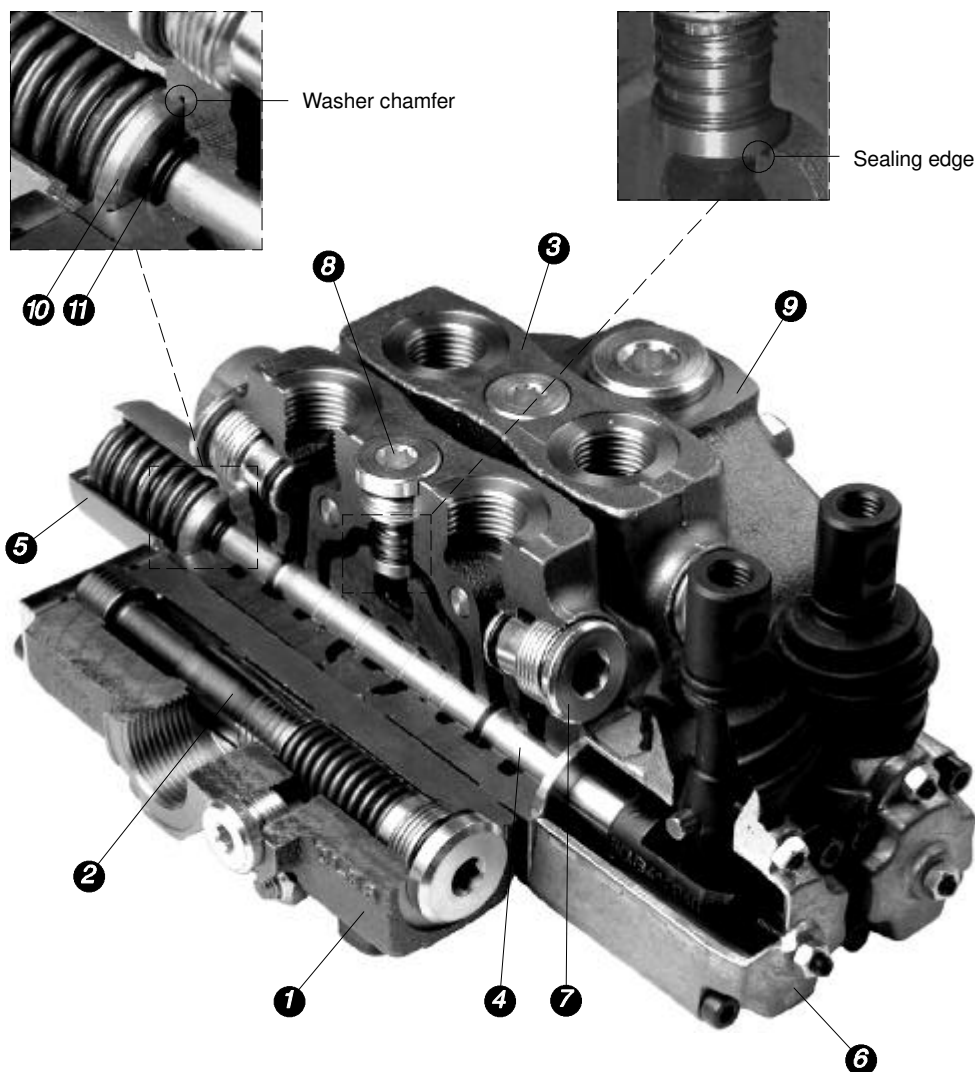

Callout	
1)	Inlet and outlet cover
2)	Compensator
3)	Working section
4)	Spool: <i>normally spools are interchangeable, verify the smoothness during the assembly</i>
5)	"A" side spool positioner
6)	Lever pivot box with stroke limiter screws
7)	Port relief valve prearrangement
8)	Load check valve
9)	Return cover
10)	Holding O-Ring washer
11)	O-Ring seal 18x2.5 code: 4GUA118025

NOTE - All moving parts inside cap, lever box and mechanical joystick are lubricated with synthetic base grease grade NLGI2

Malfunction	Cause	Remedy
External leakage pivot box lever or control kit side.	Worn spool seal due to mechanical actuation or high back pressure.	Locate the leakage and replace the seal. Check back pressure level.
Excessive internal leakage on A and B ports.	Increase clearance between spools and body due to high wear.	Replace the working section and check the oil contamination level.
Dropping load during transition while raising.	High leakage on the load check valve.	Remove the load check valve and clean the seat, verifying it's not dented.
	Pressure relief valve blocked open.	Remove and clean or replace the valve.
Inability to build pressure on A and B ports over stand-by value.	Low pump pressure and flow.	Check the pump and circuit.
	Compensator is blocked open (only with AM section configuration).	Remove and clean or replace the compensator.
	Shuttle valve on spool is blocked.	Replace the spool.

## Accessories

### Connectors

#### Type C01 code: 2X1001020

2P+T, according to DIN43650.

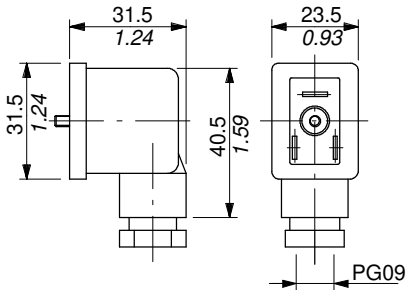

#### Type C02 code: 2X1001010

2P+T according to ISO4400 / DIN43650-A

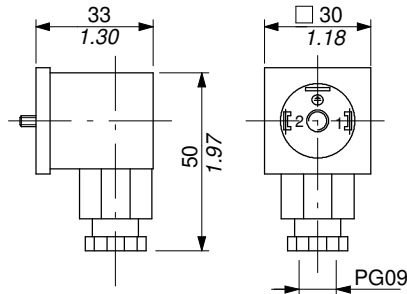

#### Type C11 code: 5CON006

4P according to VDE0660-0110

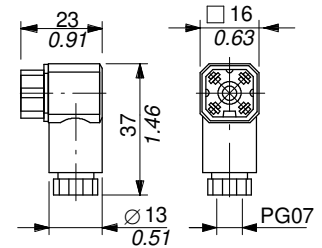

#### Type C07 code: 5CON001

2P, conforme

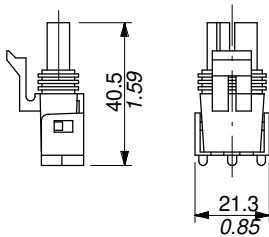

#### Type C17 code: 5CON005

2P, conforme

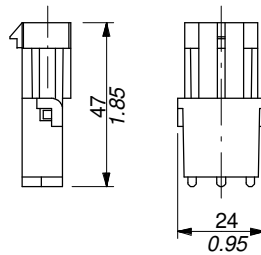

Type	Poles	Nominal voltage	Nominal current	Permitted conductor section range	Permitted cable diameter range	Weather protection
C01	2P + T	250 VAC / 300 VDC	10 A	max.1.5 mm <sup>2</sup> / max.0.0023 in <sup>2</sup>	6-8 mm / 0.24-0.31 in	IP65
C02	2P + T	250 VAC / 300 VDC	10 A	max.1.5 mm <sup>2</sup> / max.0.0023 in <sup>2</sup>	6-8 mm / 0.24-0.31 in	IP65
C11	4P	50 VAC / 120 VDC	6 A	0.14-0.5 mm <sup>2</sup> / 0.00022-0.00077 in <sup>2</sup>	4-7.5 mm / 0.16-0.29 in	IP65
C07	2P	/	20 A	1-2.5 mm <sup>2</sup> / 0.00155-0.0038 in <sup>2</sup>	2.8-3.5 mm / 0.11-0.14 in	IP67
C17	2P	/	20 A	1-2 mm <sup>2</sup> / 0.00155-0.0031 in <sup>2</sup>	2.8-3.5 mm / 0.11-0.14 in	IP67

### Fixing brackets

They are available for SD8 directional valve and they are zinc plated steel, complete with mounting screws.

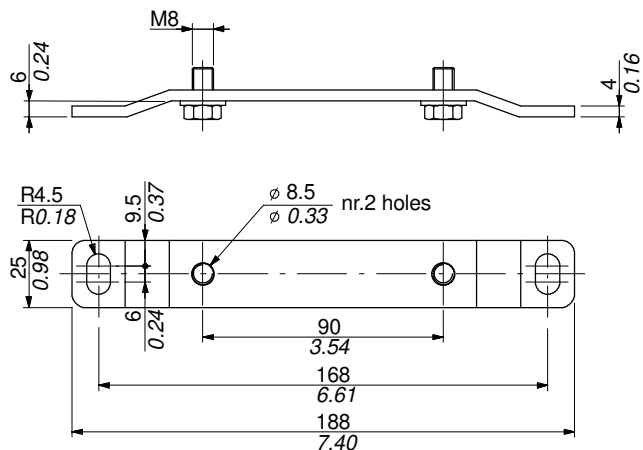
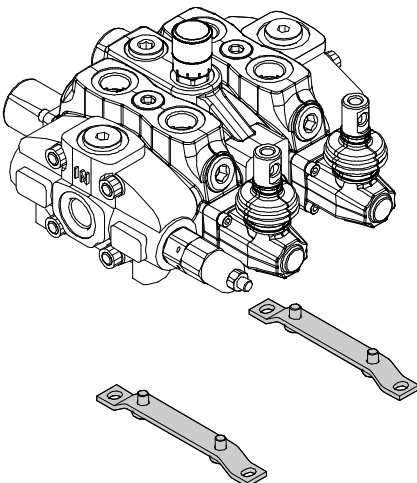





**WALVOIL S.P.A.**

42100 REGGIO EMILIA • ITALY • VIA ADIGE, 13/D  
TEL. +39.0522.932411 • FAX +39.0522.300984  
E-MAIL: INFO@WALVOIL.COM • HTTP: //WWW.WALVOIL.COM

**SALES DEPARTMENT**

TEL. +39.0522.932555 • FAX +39.0522.932455

**DBU002E**