



SDS180 DLS180

Sectional directional control valve

Features

Simple, compact and heavy duty designed sectional valve from 1 to 12 sections for open and closed centre hydraulic systems.

- Fitted with a main pressure relief valve and a load check valve on every working section
- Available with parallel, tandem or series circuit.
- Optional carry-over port.
- A wide range of antishock+anticavitation port valves.
- Intermediate sections for several types of circuit.
- Available manual, pneumatic, electrohydraulic, proportional hydraulic, spool control kits.
- Diameter 20 mm (*0.79 in*) interchangeable spools.

Additional information

This catalogue shows the product in the most standard configurations.
Please contact Sales Dpt. for more detailed information or special request.

WARNING!

All specifications of this catalogue refer to the standard product at this date.
Walvoil, oriented to a continuous improvement, reserves the right to discontinue, modify or revise the specifications, without notice.

WALVOIL IS NOT RESPONSIBLE FOR ANY DAMAGE CAUSED BY AN INCORRECT USE OF THE PRODUCT.

6th edition July 2013

SDS180

- Valve general informations
 - Working conditions page 4
 - Standard threads page 4
 - Dimensional data page 5
 - Performance data page 5
 - Hydraulic circuit page 6
 - Complete sections ordering codes page 8
 - Configuration with SDS180 and SDS150 valves coupling together ordering codes page 10
- Inlet section
 - Parts ordering codes page 11
 - Dimensional data and hydraulic circuit page 12
 - Inlet relief options. page 13
- Inlet section for special application
 - Configuration with rotary commutator. page 16
 - Configuration with electric commutator page 18
 - Configuration with flow cut-out. page 20
 - Configuration with priority valve. page 22
 - Conf. with unloader operation spool type page 24
- Working section
 - Parts ordering codes (mechanical control) page 26
 - Parts ordering codes (prop. hydraulic control) page 28
 - Dimensional data and hydraulic circuit page 29
 - Spools page 30
 - "A" side spool positioners. page 32
 - "B" side options page 40
 - Complete controls. page 43
 - Port valves. page 46
- Intermediate section
 - CS1 mid return manifold section. page 51
 - CS3 mid return manifold section. page 52
 - EI service relief valve section page 53
- Outlet section
 - Parts ordering codes page 54
 - Dimensional data and hydraulic circuit page 54

DLS180

- Valve general informations
 - Working conditions page 56
 - Standard threads page 56
 - Dimensional data page 57
 - Performance data page 57
 - Hydraulic circuit page 58
 - Complete sections ordering codes page 59
- Inlet section
 - Parts ordering codes page 60
 - Dimensional data and hydraulic circuit page 61
- Working section
 - Parts ordering codes (mechanical control) page 62
 - Parts ordering codes (prop. hydraulic control) page 63
 - Dimensional data and hydraulic circuit page 64
 - Spools page 64
 - "A" side spool positioners. page 65
 - "B" side options page 66
 - Complete controls. page 67
- Outlet section
 - Dimensional data and hydraulic circuit page 68
- Installation and maintenance page 69
- Accessories page 70

Working conditions

This catalogue shows technical specifications and diagrams measured with mineral oil of 46mm²/s - 46 cSt viscosity at 40°C - 104°F temperature.

Nominal flow rating		160 l/min	42 US gpm
	for series circuit	140 l/min	37 US gpm
Max pressure ⁽¹⁾		315 bar	4600 psi
	for series circuit	250 bar	3600 psi
Back pressure (max.)	outlet port T	25 bar	360 psi
Internal leakage (standard) A(B)⇒T	Δp = 100 bar - 1450 psi	5 cm ³ /min	0.30 in ³ /min
Fluid		Mineral based oil	
Fluid temperature	with NBR (BUNA-N) seals	from -20°C to 80°C	from -4°F to 176°F
	with FPM (VITON) seals	from -20°C to 100°C	from -4°F to 212°F
Viscosity	operating range	from 15 to 75 mm ² /s	from 15 to 75 cSt
	min.	12 mm ² /s	12 cSt
	max.	400 mm ² /s	400 cSt
Max. contamination level		-/19/16 - ISO 4406	NAS 1638 - class 10
Ambient temperature for working conditions	with mechanical devices	from -40°C to 60°C	from -40°F to 140°F
	with pneumatic and hydraulic devices	from -30°C to 80°C	from -22°F to 140°F
	with electric devices	from -20°C to 50°C	from -4°F to 122°F

NOTE - ⁽¹⁾ Intermittent pressure at max. 250,000 cycles with specific internal testing.

Standard threads

REFERENCE STANDARD			
	BSP	UN-UNF	NPTF
THREAD ACCORDING TO	ISO 228/1	ISO 263	ANSI B1.20.3
	BS 2779	ANSI B1.1 unified	
CAVITY DIMENSION ACCORDING TO	ISO 1179-1	11926-1	
	SAE	J1926-1	J476a
	DIN 3852-2 shape X or Y		

PORTS THREADING		
MAIN PORTS	BSP	UN-UNF
Inlet P	G 3/4	1 5/16-12 (SAE 16)
Ports A and B	G 3/4	1 1/16-12 (SAE 12)
Outlet T and carry-over C	G 1	1 5/16-12 (SAE 16)
PILOT PORTS		
Hydraulic	G 1/4	9/16-18 (SAE 6)
Pneumatic	NPTF 1/8-27	NPTF 1/8-27

Dimensional data

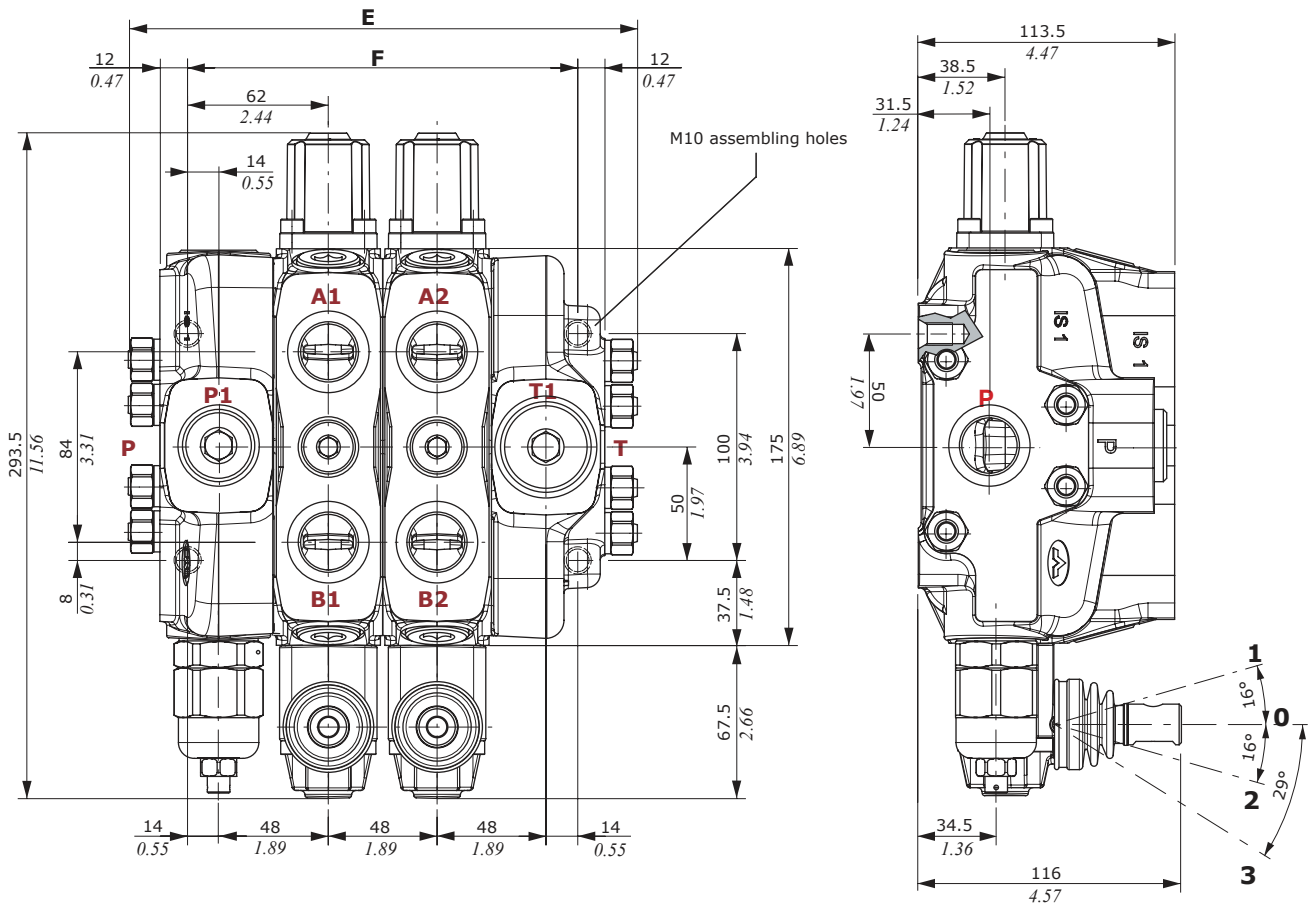

NOTE: Drawings and dimensions are referred to BSP thread configuration.

TYPE	E		F		Weight	
	mm	in	mm	in	Kg	lb
SDS180/1	176	6.93	124	4.88	13.8	30.42
SDS180/2	224	8.82	172	6.77	19.2	42.33
SDS180/3	272	10.71	220	8.66	24.6	54.23
SDS180/4	320	12.60	268	10.55	30	66.14
SDS180/5	368	14.49	316	12.44	35.4	78.04
SDS180/6	416	16.38	364	14.33	40.8	89.95

TYPE	E		F		Weight	
	mm	in	mm	in	Kg	lb
SDS180/7	464	18.27	412	16.22	46.2	101.85
SDS180/8	512	20.16	460	18.11	51.6	113.76
SDS180/9	560	22.05	508	20.00	57	125.66
SDS180/10	608	23.94	556	21.89	62.4	137.57
SDS180/11	656	25.83	604	23.78	67.8	149.47
SDS180/12	704	27.72	652	25.67	73.2	161.38

Performance data

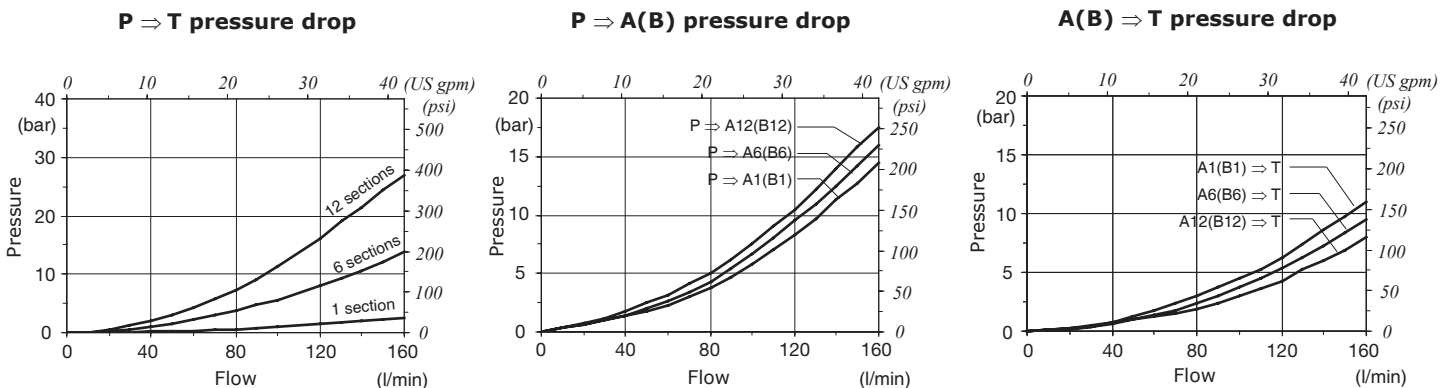

Hydraulic circuit

Parallel circuit

Standard configuration with open centre and side inlet and outlet.

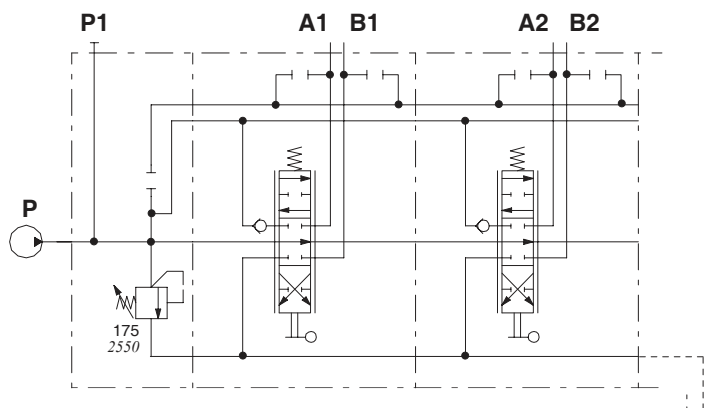

Description example:
SDS180/2/AC(YG3-120)/18L.UT3/18L.UT3/.....

Series-parallel (tandem) circuit

It needs a special working section kit.

Tandem section is fed from the free flow pressure line; it's excluded when an up stream section is operated.

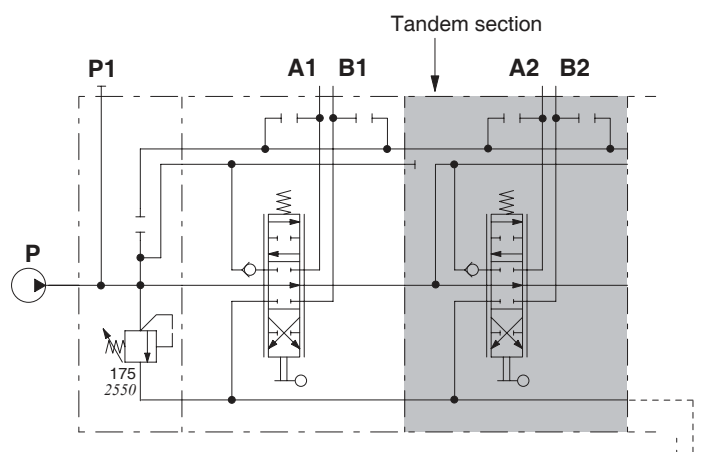

Description example:
SDS180/2/AC(YG3-120)/18L.UT3/**SP**-18L.UT3/.....

Series circuit

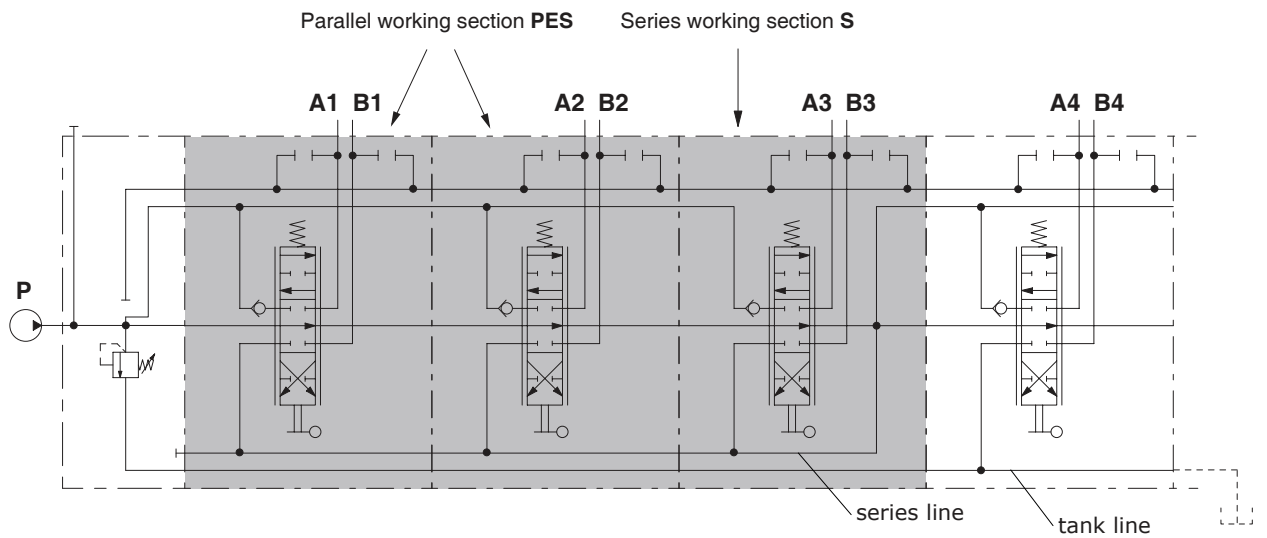

Description example:
 SDS180/4/AC(YG3-120)/PES-18L.UT3/PES-18L.UT3/S-18L.UT3/18L.UT3/.....

Right inlet directional valve

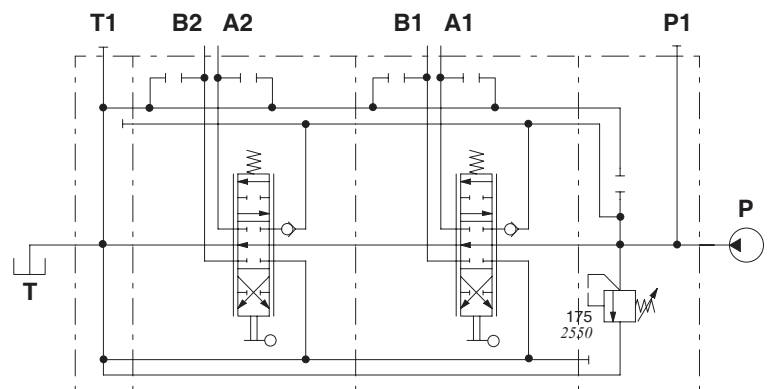
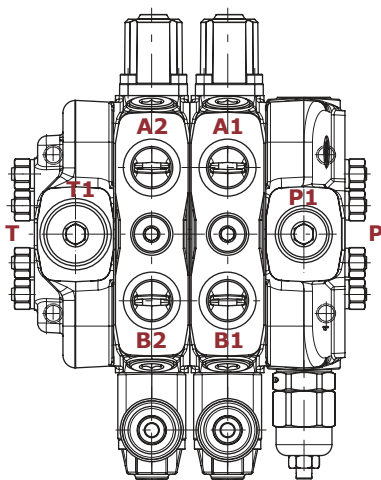

Description example:
 SDS180/2/BC(YG3-120)/18L.UT3/18L.UT3/RC

Complete sections ordering codes

Standard configuration with side inlet and outlet

SDS180 / 2 / AC(YG3-120) / 18L.UT3 / EI1(YG3-180) / 18L.UT3 / RC - STAF

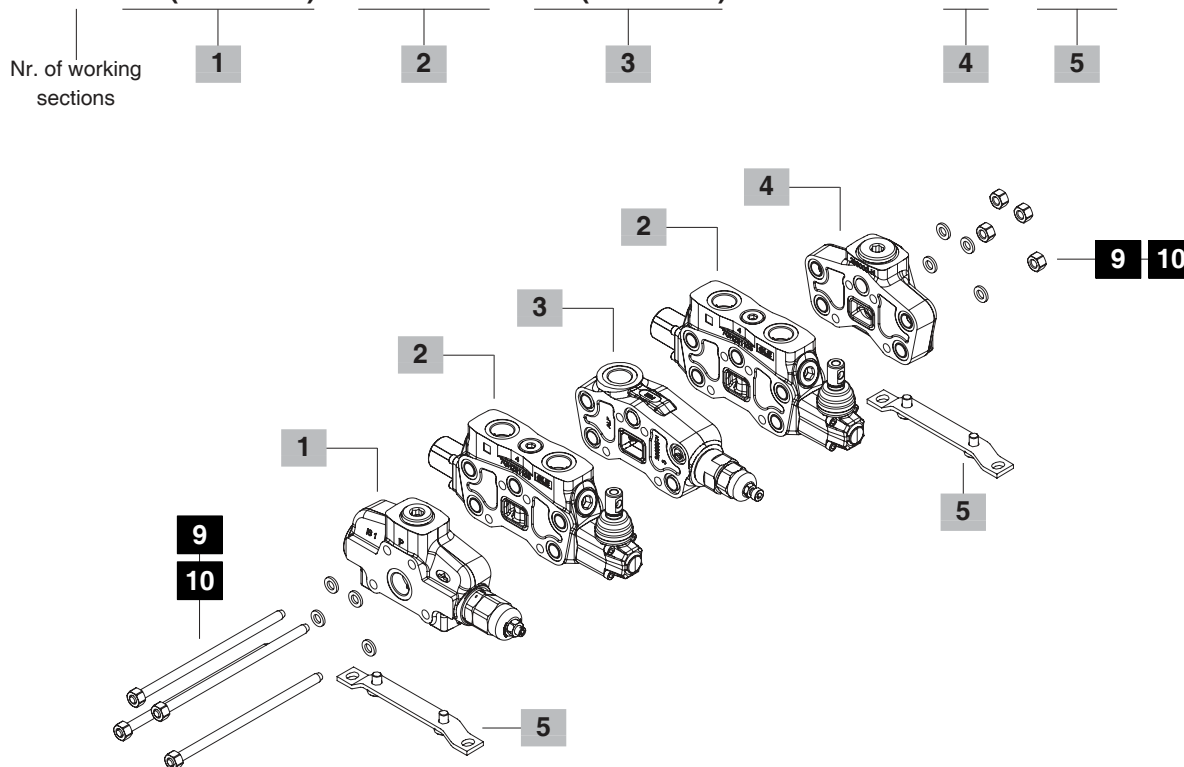

1 Inlet section * page 11

TYPE	CODE	DESCRIPTION
AC(YG3-120)	618201005	With direct pressure relief valve
AC(XG-120)	618201004	With pilot pressure relief valve
AC(SV)	618201006	Without pressure relief valve
AC(YG3-120)R2	618201007	With direct pressure relief valve and rotary commutator
AC(YG3-120)R2E	618201008	With direct pressure relief valve and electric commutator 12VDC
M(LSW-120)ELNW(NC)	618201009	With flow cut-out and LS pressure relief valve
ACD/VPD	618201018	With double stage pressure relief valve and priority valve
BCHW	618201029	With unloader operation spool type and LS press. relief valve 12VDC

2 Working section * page 26

TYPE	CODE	DESCRIPTION
P-18L	618101003	Parallel circuit, prearranged for port valves, double acting spool with spring return, lever control
SP-18L	618105005	As previous with series-parallel (tandem) circuit
P-1IM8IM	618101004	Parallel circuit, proportional hydraulic control
S-18L	615111001	Series circuit, lever control
PES-18L	618101031	Parallel circuit, lever control

3 Intermediate sections * page 53

TYPE	CODE	DESCRIPTION
EI1(YG3)	618401001	With direct pressure relief valve

4 Outlet section * page 54

TYPE	CODE	DESCRIPTION
RC	618301003	Side outlet
RD	618301002	Upper outlet
RE	618301001	Upper outlet with side carry-over sleeve
RK	618301004	Upper outlet with closed center
RV	618301009	With backpressure valve

5 Fixing bracket page 73

TYPE	CODE	DESCRIPTION
STAF	5STA125220	Brackets with fixing screws

NOTE (*) – Codes are referred to **BSP** thread.

Complete sections ordering codes

Configuration with 2 side inlets and mid return manifold

SDS180 / 2 / AC(YG3-120) / 18L.UT3 / CS1 / ED-18L.UT3 / BC(YG3-120) - STAF

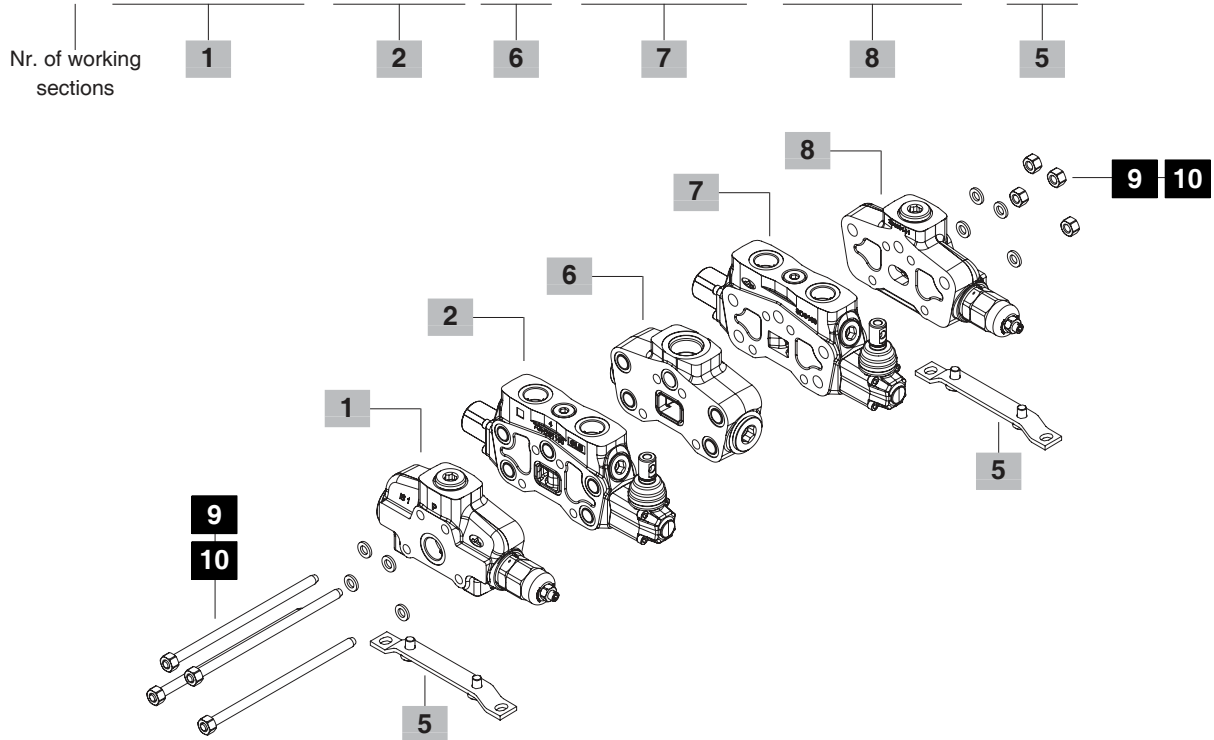

6 Return manifold * page 51

TYPE	CODE	DESCRIPTION
CS1	615401010	Mid return manifold

7 Right inlet working section *

TYPE	CODE	DESCRIPTION
ED-P-18L	618101041	Parallel circuit, prearranged for port valves, double acting spool with spring return, lever control
ED-SP-18L	618101043	As previous with series-parallel (tandem) circuit

8 Right inlet section *

TYPE	CODE	DESCRIPTION
BC(YG3-120)	618201025	Side inlet with direct press. relief valve
BC(XG-120)	618201026	Side inlet with pilot pressure relief valve
BC(SV)	618201027	Side inlet without pressure relief valve
BD(YG3-120)	618201028	Upper inlet with direct pressure relief valve

9 Assemb. kit without intermediate section

CODE	DESCRIPTION
5TIR110170	Tie rod kit for 1 working section directional valve
5TIR110218	Tie rod kit for 2 working sections directional valve
5TIR110266	Tie rod kit for 3 working sections directional valve
5TIR110316	Tie rod kit for 4 working sections directional valve
5TIR110368	Tie rod kit for 5 working sections directional valve
5TIR110410	Tie rod kit for 6 working sections directional valve
5TIR110458	Tie rod kit for 7 working sections directional valve
5TIR110506	Tie rod kit for 8 working sections directional valve
5TIR110554	Tie rod kit for 9 working sections directional valve
5TIR110602	Tie rod kit for 10 working sections directional valve
5TIR110650	Tie rod kit for 11 working sections directional valve
5TIR110698	Tie rod kit for 12 working sections directional valve

10 Assemb. kit with intermediate section

CODE	DESCRIPTION
5TIR110266	Tie rod kit for 2 working sections directional valve
5TIR110316	Tie rod kit for 3 working sections directional valve
5TIR110368	Tie rod kit for 4 working sections directional valve
5TIR110410	Tie rod kit for 5 working sections directional valve
5TIR110458	Tie rod kit for 6 working sections directional valve
5TIR110506	Tie rod kit for 7 working sections directional valve
5TIR110554	Tie rod kit for 8 working sections directional valve
5TIR110602	Tie rod kit for 9 working sections directional valve
5TIR110650	Tie rod kit for 10 working sections directional valve
5TIR110698	Tie rod kit for 11 working sections directional valve
5TIR110746	Tie rod kit for 12 working sections directional valve

NOTE (*) – Codes are referred to **BSP** thread.

Configuration with SDS180 and SDS150 valves coupling together ordering codes _____

SDS180/2/AC(YG3-120)/18L.UT3/18L.UT3 / CS3 / 18L.UT3/18L.UT3/BC(YG3-120)/SDS150/2

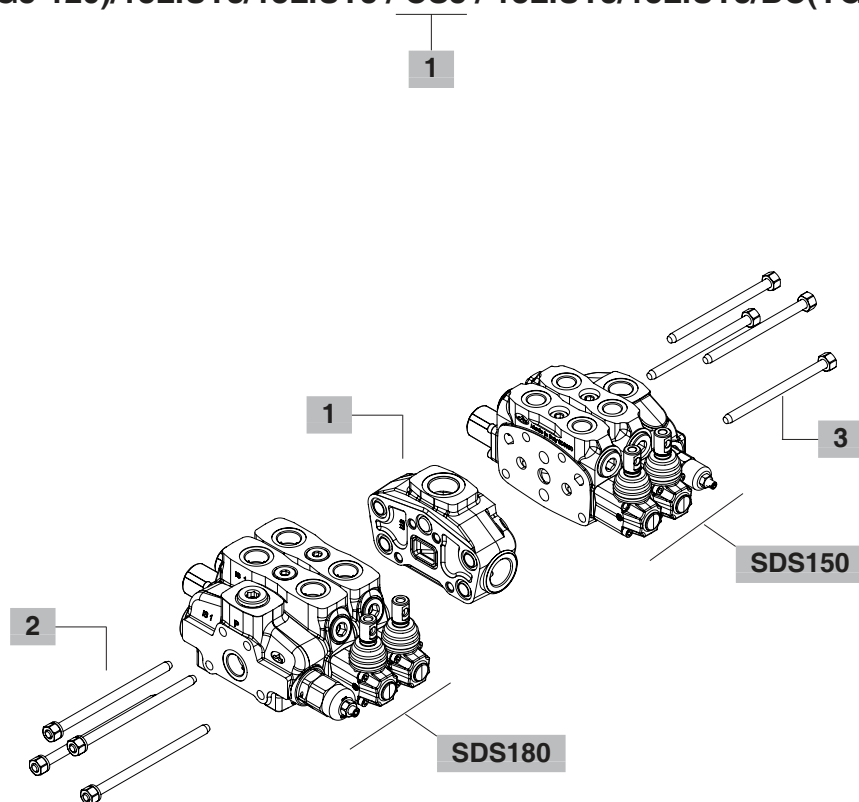

1 Return manifold *

TYPE	CODE	DESCRIPTION
CS3	615441010	Mid return manifold

2 Assembling kit for SDS180 valve side

CODE	DESCRIPTION
5TIR4161	Tie rod kit for 1 working section directional valve
5TIR4162	Tie rod kit for 2 working sections directional valve
5TIR4163	Tie rod kit for 3 working sections directional valve
5TIR4164	Tie rod kit for 4 working sections directional valve
5TIR4165	Tie rod kit for 5 working sections directional valve
5TIR4166	Tie rod kit for 6 working sections directional valve
5TIR4167	Tie rod kit for 7 working sections directional valve
5TIR4168	Tie rod kit for 8 working sections directional valve
5TIR4169	Tie rod kit for 9 working sections directional valve
5TIR416A	Tie rod kit for 10 working sections directional valve

3 Assembling kit for SDS150 valve side

CODE	DESCRIPTION
5TIR41501	Tie rod kit for 1 working section directional valve
5TIR41502	Tie rod kit for 2 working sections directional valve
5TIR41503	Tie rod kit for 3 working sections directional valve
5TIR41504	Tie rod kit for 4 working sections directional valve

NOTE (*) – Codes are referred to **BSP** thread.

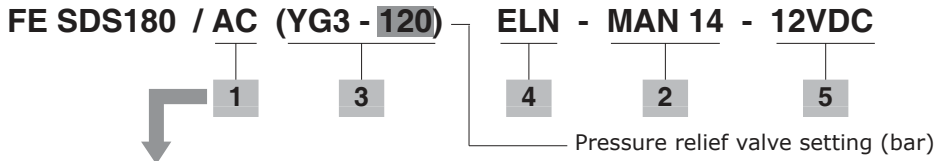

Available configurations

- AC:** with side inlet, for left inlet (standard) directional valve
- AD:** with upper inlet, for left inlet (standard) directional valve
- BC:** with side inlet, for right inlet directional valve
- BD:** with upper inlet, for right inlet directional valve

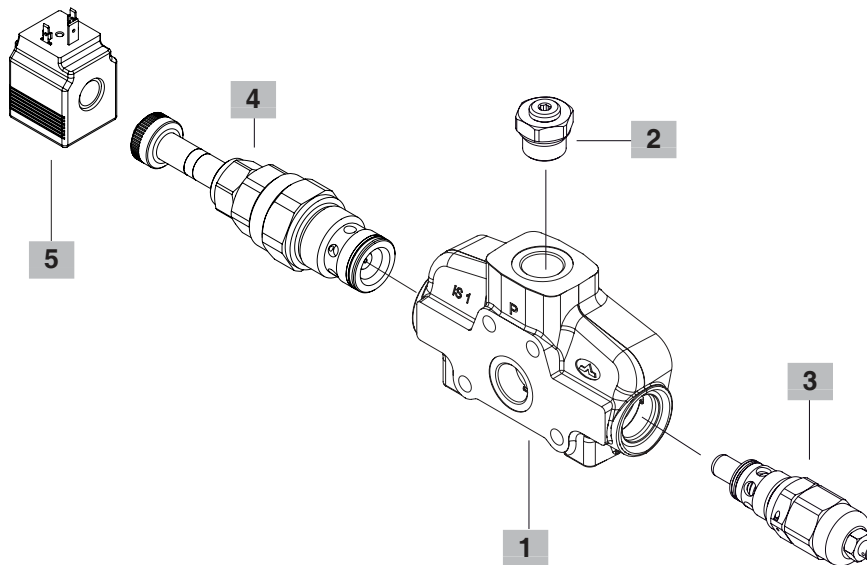

1 Inlet cover body * page 12

CODE: 3FIA118301-H
DESCRIPTION: Standard body

2 Parts *

TYPE	CODE	DESCRIPTION
-	3XTAP732200	G3/4 plug (omit in description)
MAN18	5MAN632230	G1/8 Pressure gauge arrangement
MAN14	5MAN632231	G1/4 Pressure gauge arrangement

3 Inlet relief valve options page 13

Standard setting is referred to 10 l/min - 2.6 US gpm flow.

TYPE	CODE	DESCRIPTION
SV	3XTAP535410	Relief valve blanking plug
VMP20/1 pilot operated pressure relief valve type X (XG-120)		
	X007211120	Range 60-250 bar / 870-3600 psi standard setting 120 bar / 1750 psi
(XGN-120)	XCAR120313	As previous without filter

VMD20/1 direct pressure relief valve type Y (standard)

(YG2-80)	3XCAR120212	Range 63-125 bar / 900-1800 psi standard setting 80 bar / 1150 psi
(YG3-120)	3XCAR120213	Range 100-200 bar / 1450-2900 psi standard setting 175 bar / 2500 psi
(YG4-250)	3XCAR120214	Range 160-320 bar / 2300-4650 psi standard setting 250 bar / 3600 psi

Double stage relief valve (pilot port SAE 8)

(XGD)	1130040408	Setting 207 and 235 bar / 3000 and 3400 psi
--------------	------------	---

4 Inlet valve options page 15

TYPE	CODE	DESCRIPTION
-	3XTAP535410	Relief valve blanking plug (omit in description)
F	5KIT420200	Inlet anti-cavitation valve
L	3XCAR420300	Hydraulic operated
Solenoid operated unloader valve		
ELN	YEF08002000	Without emergency
ELP	YEF08002002	Push-button emergency
ELV	YEF08002003	Screw type emergency
ELT	YEF08002004	Push and twist type with detent emergency

5 Coils page 70

TYPE	CODE	DESCRIPTION
12VDC	4SLE001200	Coil type BER , ISO4400 integrated type 12 VDC

For complete available coils list see page 70

NOTE (*) – Codes are referred to **BSP** thread.

Dimensional data and hydraulic circuit

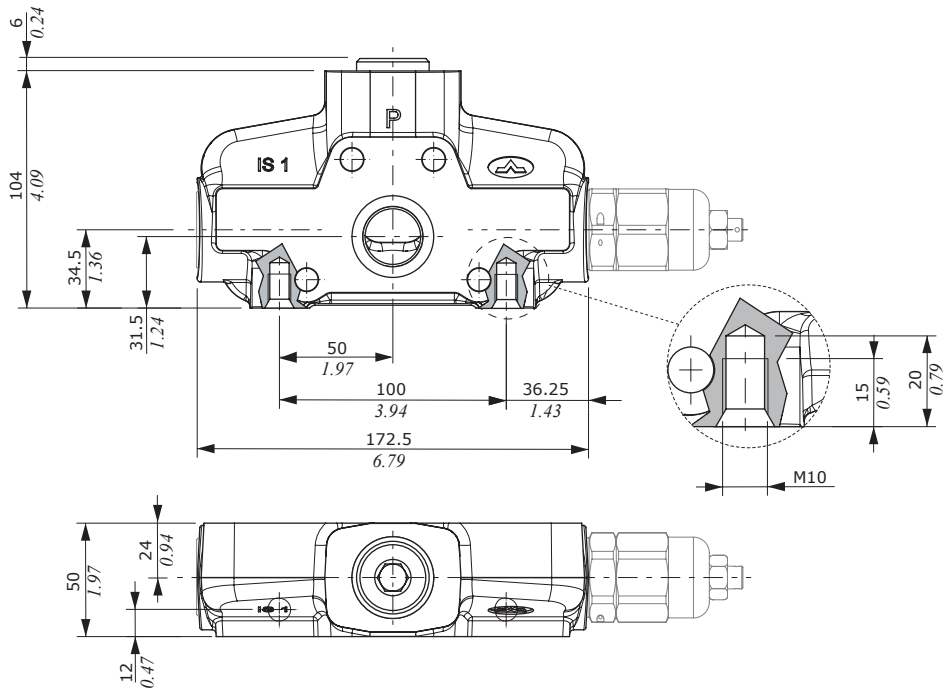

For left inlet directional valve, side port

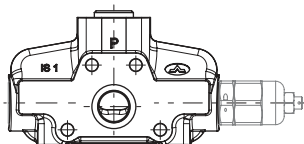
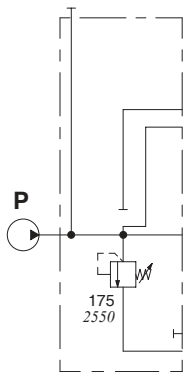

Description example:
AC(YG3-175)

For left inlet directional valve, upper port

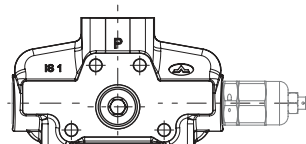
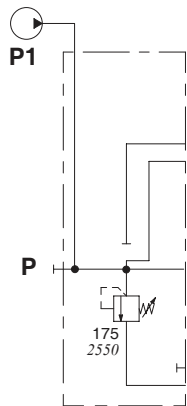

Description example:
AD(YG3-175)

For right inlet directional valve, side port

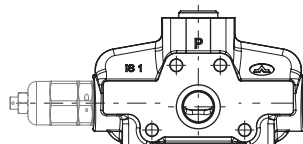
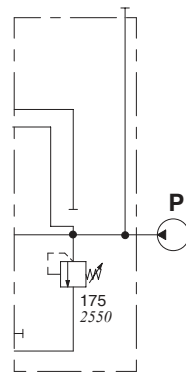

Description example:
BC(YG3-175)

For right inlet directional valve, upper port

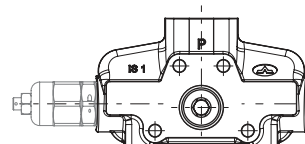
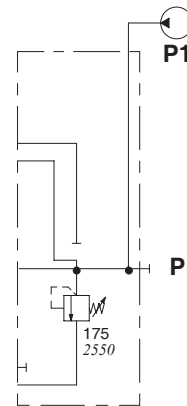

Description example:
BD(YG3-175)

Direct overpressure relief valve

Description example: Y G 3 - 120



Configuration type G: adjustable with screw

Configuration type H: valve set and locked

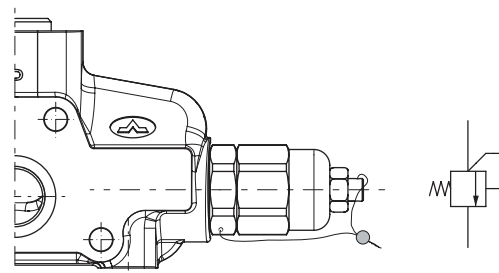
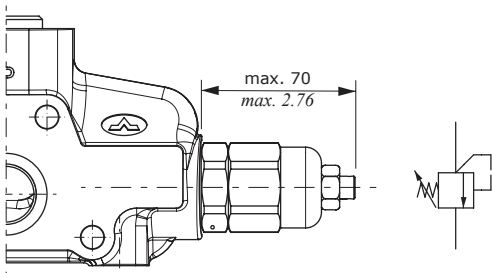

YG2 valve setting range
(green band)

From 63 to 125 bar / from 900 to 1800 psi

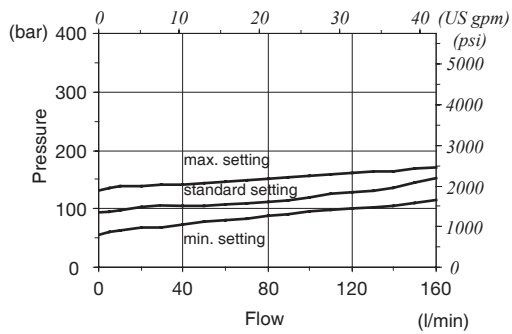

YG3 valve setting range
(blue band)

From 100 to 200 bar / from 1450 to 2900 psi

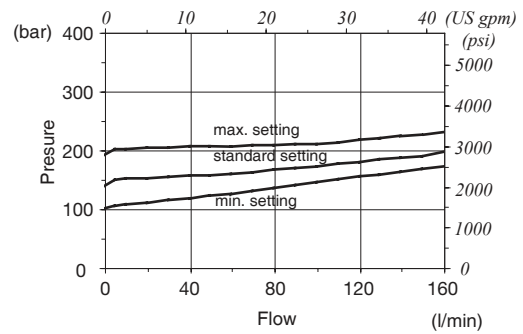

YG4 valve setting range
(red band)

From 160 to 320 bar / from 2300 to 4650 psi

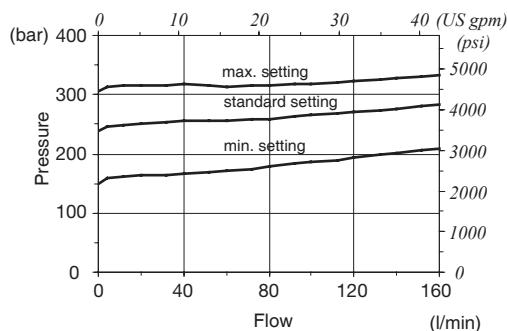

Inlet relief options

Pilot operated overpressure relief valve

Description example: **X G N - 120**

Configuration — Valve setting (bar)
 — Without filter

Configuration type **G**: adjustable with screw

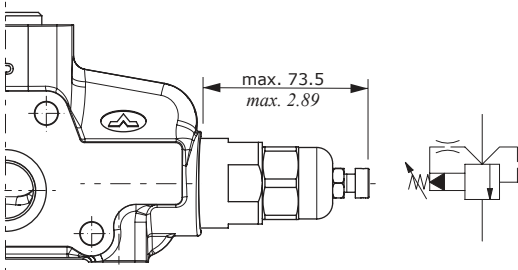

Configuration type **Z**: valve set and locked with cap

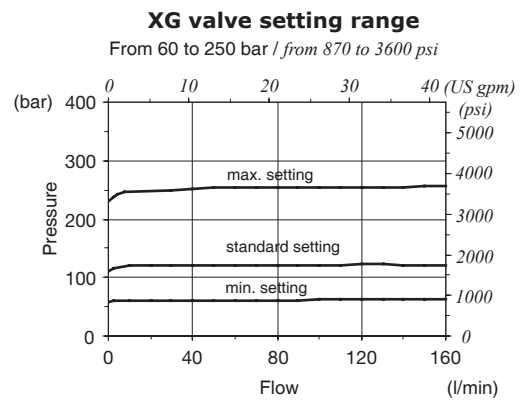
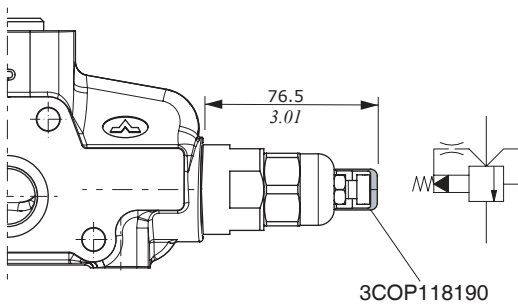

Double stage relief valve

Description example: **X G D 3 - 120**

Valve setting (bar)
 Spring type

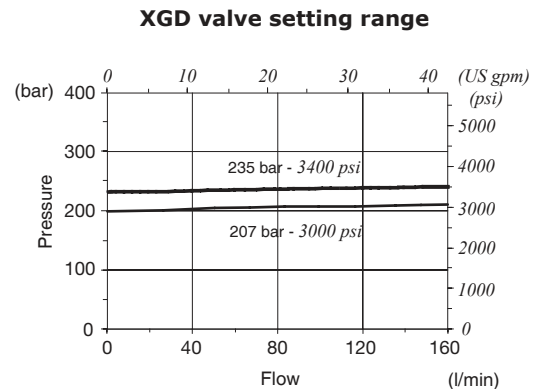
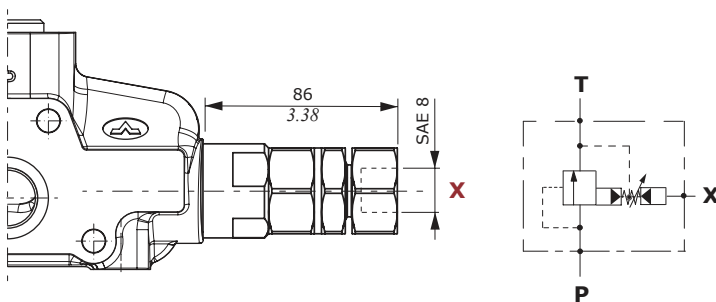

Note: valve available with SAE pilot; for executions with different thread contact the Sales Dpt.

Unloader valves

Description example: AC (YG3 - 120) **ELT - 12VDC**

Hydraulic operated valve: **L**
 Solenoid operated valve: **ELN** Feeding voltage: for solenoid operated
ELP
ELV
ELT

Solenoid operated

Emergency with push button and spring return; for detent position turn the button after press it.
WARNING: the manual override option is intended for emergency use, not for continuous duty operation.

Hydraulic operated

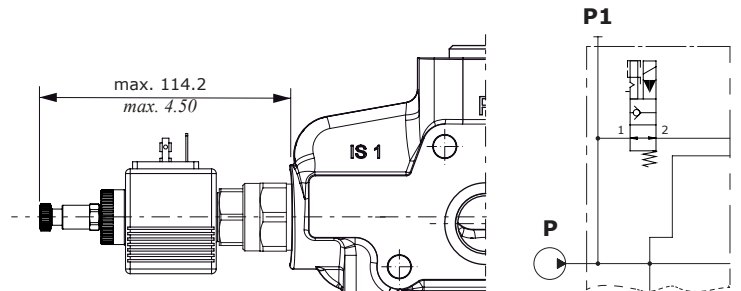
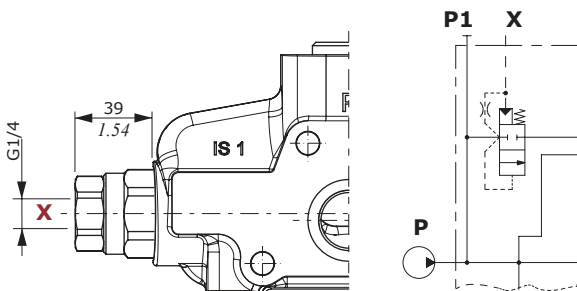

ELN: without emergency

ELP: push button type

ELV: screw type

ELT: "push & twist" type

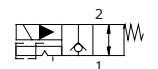
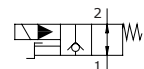
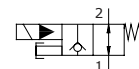
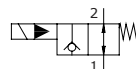

Pressure drop valve type L on SDS180/2

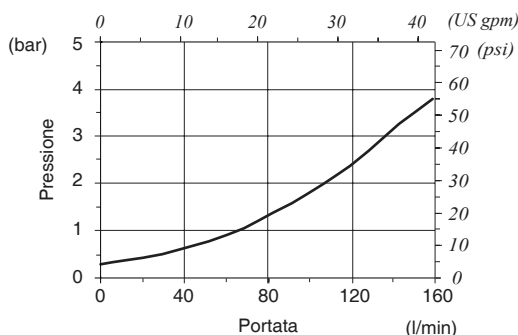

Features

Max. flow 120 l/min - 31.7 US gpm
 Internal leakage 10 cm³/min @ 100 bar
 0.61 in³/min @ 1450 psi

Pressure drop EL valve on SDS180/2

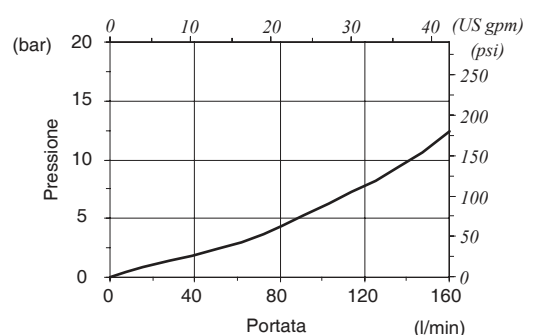

Features

Max. flow 40 l/min - 10.6 US gpm
 Max. pressure 350 bar - 5100 psi
 Internal leakage 50 cm³/min @ 210 bar
 3.05 in³/min @ 3050 psi

For coil **BER** see page 71

Anti-cavitation valve

Description example: AC (YG3 - 120) **F**

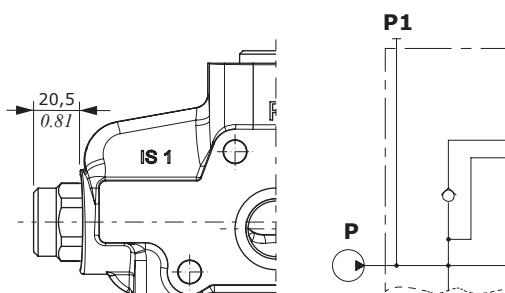

Pressure drop

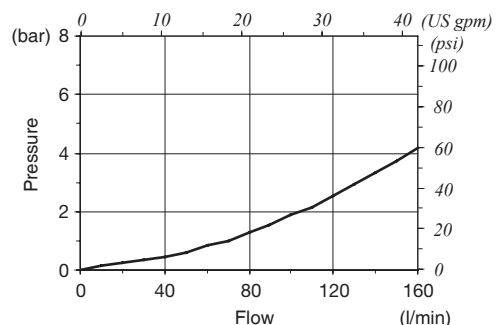

Configuration with rotary commutator

FE SDS180 / AC ELN - 12VDC - R2

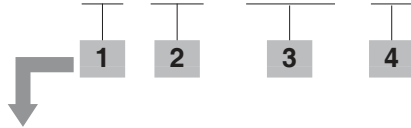

Available configurations

- AC:** with side inlet, for left inlet (standard) directional valve
- AD:** with upper inlet, for left inlet (standard) directional valve
- BC:** with side inlet, for right inlet directional valve
- BD:** with upper inlet, for right inlet directional valve

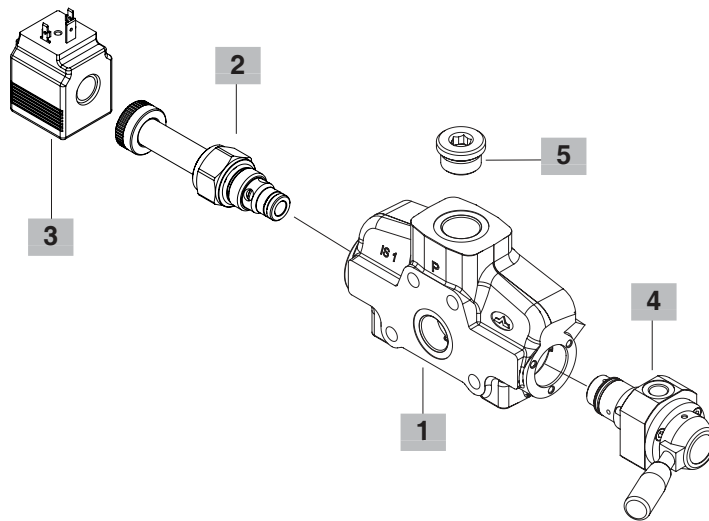

1 Inlet cover body * page 17

CODE: 3FIA118311-H
DESCRIPTION: Standard body for left inlet

2 Inlet valve options page 13

Standard setting is referred to 10 l/min - 2.6 US gpm flow.

INLET RELIEF OPTIONS

TYPE	CODE	DESCRIPTION
SV	3XTAP535410	Relief valve blanking plug
VMP20/1 pilot operated pressure relief valve type X		
(XG-120)	X007211120	Range 60-250 bar / 900-3600 psi standard setting 120 bar / 1750 psi
(XGN-120)	XCAR120313	As previous without filter
VMD20/1 direct pressure relief valve type Y (standard)		
(YG2-80)	3XCAR120212	Range 63-125 bar / 900-1800 psi standard setting 80 bar / 1150 psi
(YG3-120)	3XCAR120213	Range 100-200 bar / 1450-2900 psi standard setting 175 bar / 2500 psi
(YG4-250)	3XCAR120214	Range 160-320 bar / 2300-4650 psi standard setting 250 bar / 3600 psi

Double stage relief valve (pilot port SAE 8)

(XGD) 1130040408 Setting 207 and 235 bar / 3000 and 3400 psi

INLET VALVE OPTIONS

TYPE	CODE	DESCRIPTION
F	5KIT420200	Inlet anti-cavitation valve
L	3XCAR420300	Hydraulic operated unloader valve

Solenoid operated unloader valve

ELN	YEF08002000	Without emergency
ELP	YEF08002002	Push-button emergency
ELV	YEF08002003	Screw type emergency
ELT	YEF08002004	Push and twist type with detent emergency

3 Coils page 70

TYPE	CODE	DESCRIPTION
12VDC	4SLE001200	Type BER , ISO4400 integrated type 12 VDC

For complete available coils list see page 70

4 Commutator *

TYPE	CODE	DESCRIPTION
R2	5COM416203	Rotary commutator

5 Parts *

CODE	DESCRIPTION
3XTAP732200	G3/4 Plug

NOTE (*) - Codes are referred to **BSP** thread.

Configuration with rotary commutator

Dimensional data and hydraulic circuit

Drawing and circuit are referred to left inlet directional valve.

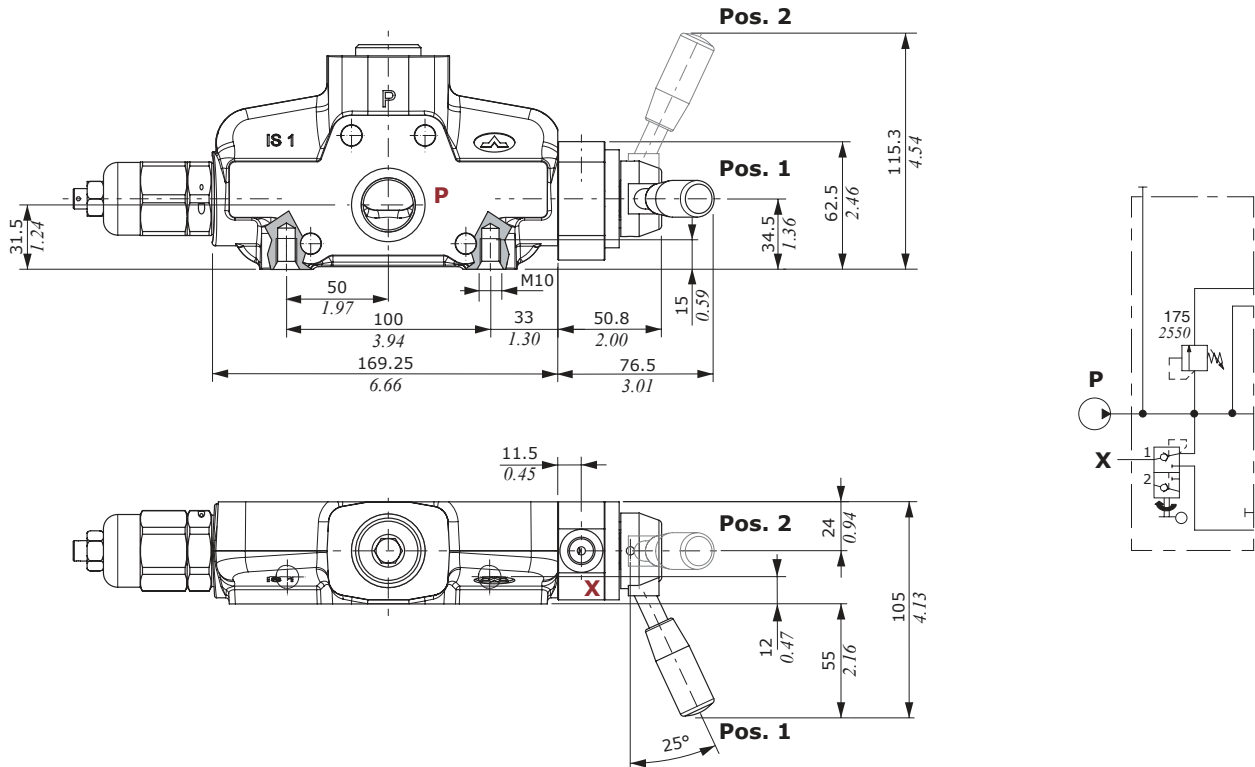

Features

- Max. pressure : 210 bar - 3050 psi
- Internal leakage : 0.30 cm³/min @ 210 bar
0.018 in³/min @ 3050 psi

Configuration with electric commutator

FE SDS180 / AC (YG3 - 120) R2E - 12VDC

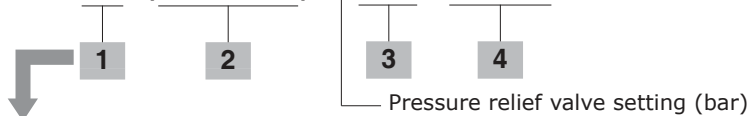

Available configurations

- AC: with side inlet, for left inlet (standard) directional valve
- AD: with upper inlet, for left inlet (standard) directional valve
- BC: with side inlet, for right inlet directional valve
- BD: with upper inlet, for right inlet directional valve

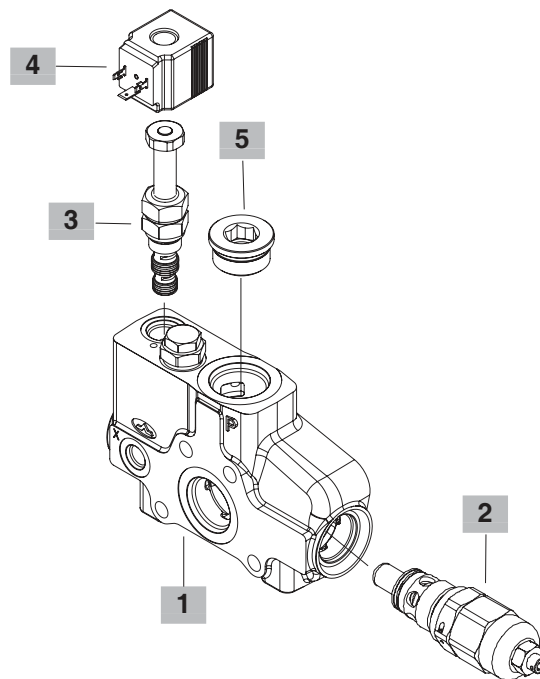

1 Inlet cover body * page 19

CODE: 5FIA118361
DESCRIPTION: Standard body

2 Inlet valve options page 13

Standard setting is referred to 10 l/min - 2.6 US gpm flow.

TYPE	CODE	DESCRIPTION
SV	3XTAP535410	Relief valve blanking plug
F	5KIT420200	Inlet anti-cavitation valve
L	3XCAR420300	Hydraulic operated unloader valve
VMP20/1 pilot operated pressure relief valve type X		
(XG-120)	X007211120	Range 60-250 bar / 900-3600 psi standard setting 120 bar / 1750 psi
(XGN-120)	XCAR120313	As previous without filter
VMD20/1 direct pressure relief valve type Y (standard)		
(YG2-80)	3XCAR120212	Range 63-125 bar / 900-1800 psi standard setting 80 bar / 1150 psi
(YG3-120)	3XCAR120213	Range 100-200 bar / 1450-2900 psi standard setting 175 bar / 2500 psi
(YG4-250)	3XCAR120214	Range 160-320 bar / 2300-4650 psi standard setting 250 bar / 3600 psi

Double stage relief valve (pilot port SAE 8)
(XGD) 1130040408 Setting 207 and 235 bar / 3000 and 3400 psi

2 Inlet valve options (continued) page 13

Solenoid operated unloader valve

TYPE	CODE	DESCRIPTION
ELN	YEF08002000	Without emergency
ELP	YEF08002002	Push-button emergency
ELV	YEF08002003	Screw type emergency
ELT	YEF08002004	Push and twist type with detent emerg.

3 Electric commutator *

TYPE	CODE	DESCRIPTION
R2E	0EJ08002048	Electric commutator, ISO4400 connector

For complete available coils list see page 71

4 Coils Page 70

TYPE	CODE	DESCRIPTION
12VDC	4SLE001200	Coil BER 12VDC-ISO4400

For complete available coils list see page 70

5 Parts *

CODE	DESCRIPTION
3XTAP732200	G3/4 Plug

NOTE (*) - Codes are referred to **BSP** thread.

Configuration with electric commutator

Dimensional data and hydraulic circuit

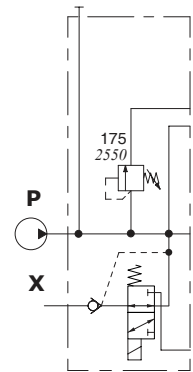
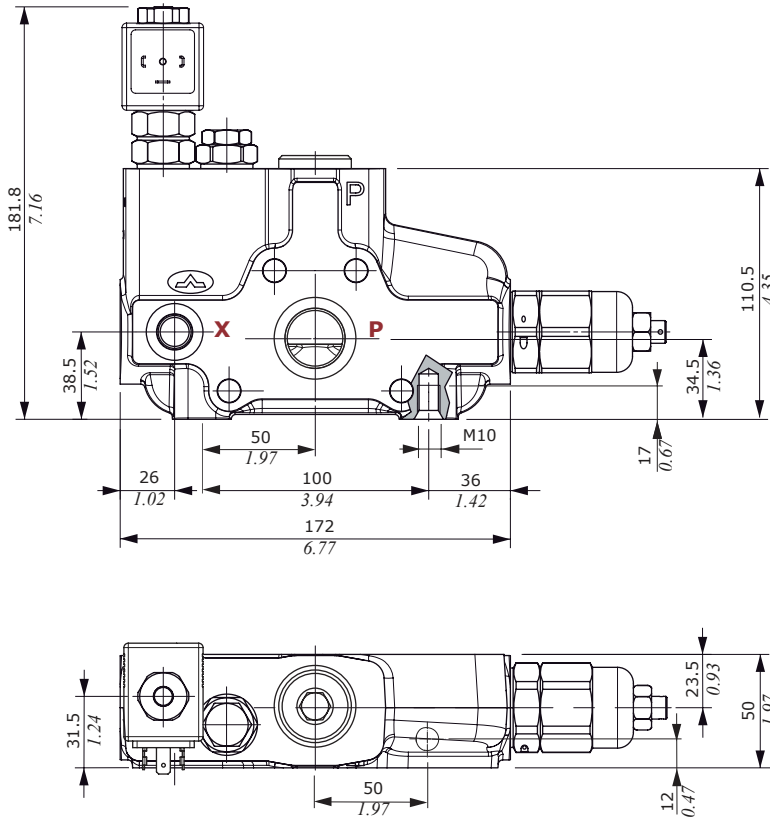

Features

- Max. pressure : 350 bar - 5100 psi
- Max. flow : 40 l/min - 10.6 US gpm
- Internal leakage : 0.25 cm³/min @ 210 bar
0.015 in³/min @ 3050 psi

For coil **BER** see page 71

Configuration with flow cut-out

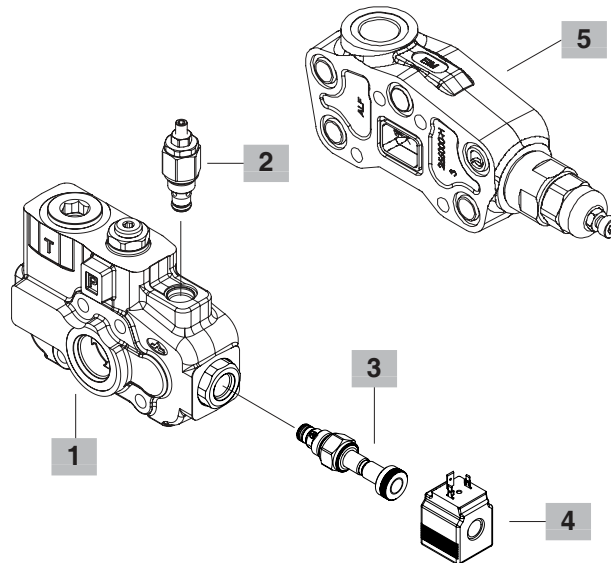
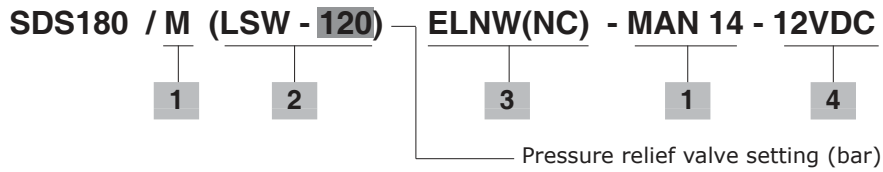

1 Inlet cover body * page 21

CODE: 5FIA118372
DESCRIPTION: with flow cut-out

2 Inlet valve options page 21

Standard setting is referred to 10 l/min - 2.6 US gpm flow.

TYPE	CODE	DESCRIPTION
SV	XTAP525320	Relief valve blanking plug
Main relief valve		
LSW(G2)	5KIT118110	Range 5-50 bar / 72-720 psi standard setting 30 bar / 400 psi
LSW(G3)	5KIT118111	Range 50-200 bar / 720-2900 psi standard setting 150 bar / 2150 psi
LSW(G4)	5KIT118112	Range 180-315 bar / 2600-4550 psi standard setting 250 bar / 3600 psi

3 Unloader valve options page 21

TYPE	CODE	DESCRIPTION
ELNW(NO)	0EF08002000	Without manual emergency, NO circuit
ELNW(NC)	0EF08002001	Without manual emergency, NC circuit
ELTW(NO)	0EF08002004	"Push&twist" manual emergency, NO circuit
ELPW(NO)	0EF08002002	Push-button manual emergency, NO circuit
ELVW(NO)	0EF08002003	Screw type manual emergency, NO circuit

4 Coils page 70

TYPE	CODE	DESCRIPTION
12VDC	4SL2000121	Coil BER 12VDC-ISO4400

For complete available coils list see page 70

5 Intermediate section * page 53

TYPE	CODE	DESCRIPTION
EIM(XG-220)	618421001	intermediate section with pressure relief valve

NOTE: inlet cover with flow cut-out must be **always** assembled with EIM intermediate section.

NOTE (*) - Codes are referred to **BSP** thread.

Configuration with flow cut-out

Dimensional data and hydraulic circuit

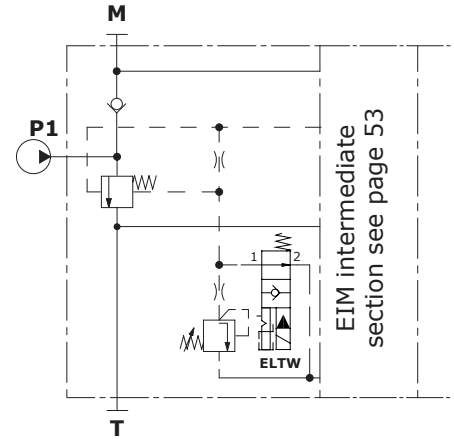
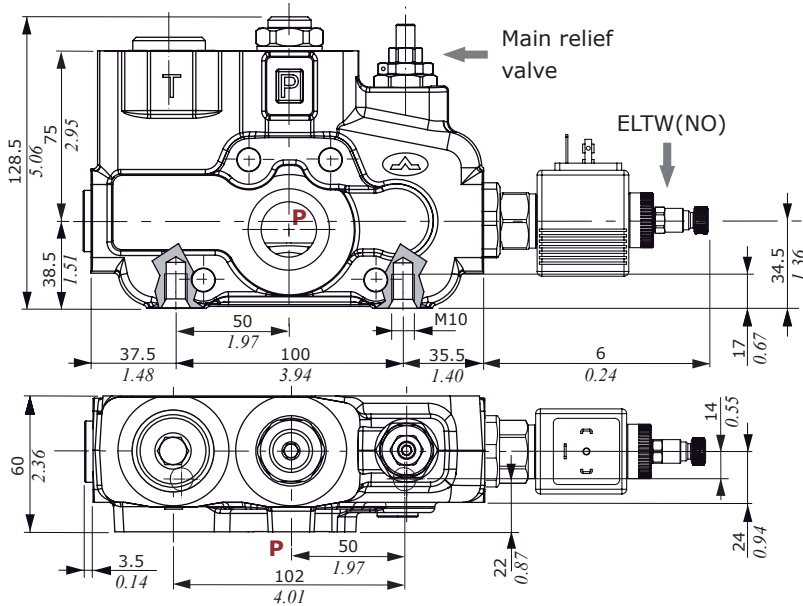

ELNW(NO):
without
emergency

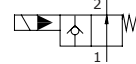

ELNW(NC):
without
emergency

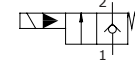

ELPW(NO):
push button
type

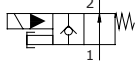

ELTW(NO):
"push & twist"
type

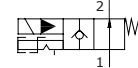

ELVW(NO):
screw type

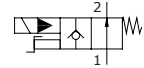

Main relief valve diagrams

Type (G2) setting range

From 5 to 50 bar / from 72 to 720 psi

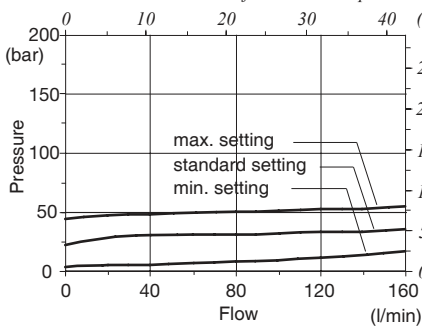

Type (G3) setting range

From 50 to 200 bar / from 720 to 2900 psi

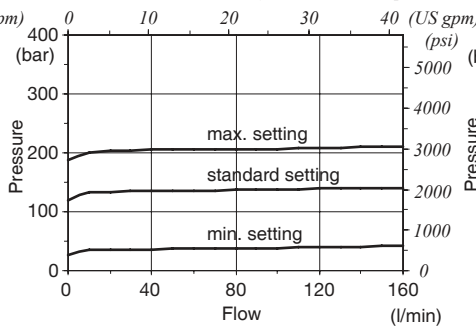

Type (G4) setting range

From 180 to 315 bar / from 2600 to 4550 psi

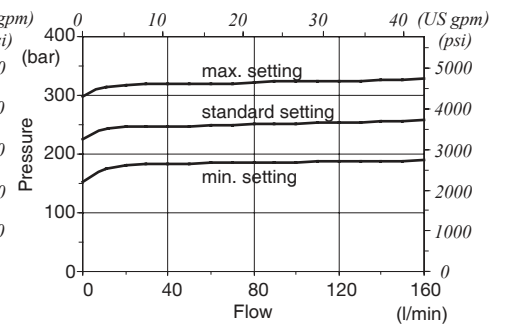

Pressure drop P ⇒ T
on flow cut-out

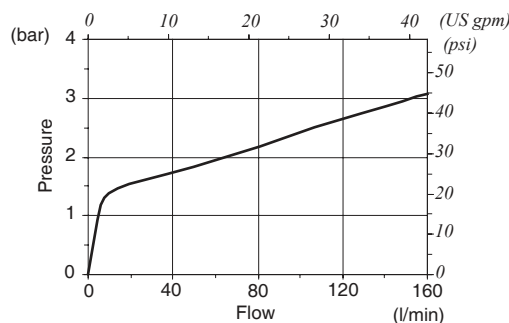

Configuration with priority valve

FE SDS180 / ACD / VPD (LSZ - 230) \ YG3 - 120) - SAE

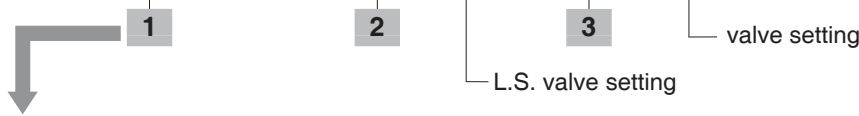

Available configurations

- AC: with side inlet, for left inlet (standard) directional valve
- AD: with upper inlet, for left inlet (standard) directional valve
- BC: with side inlet, for right inlet directional valve
- BD: with upper inlet, for right inlet directional valve

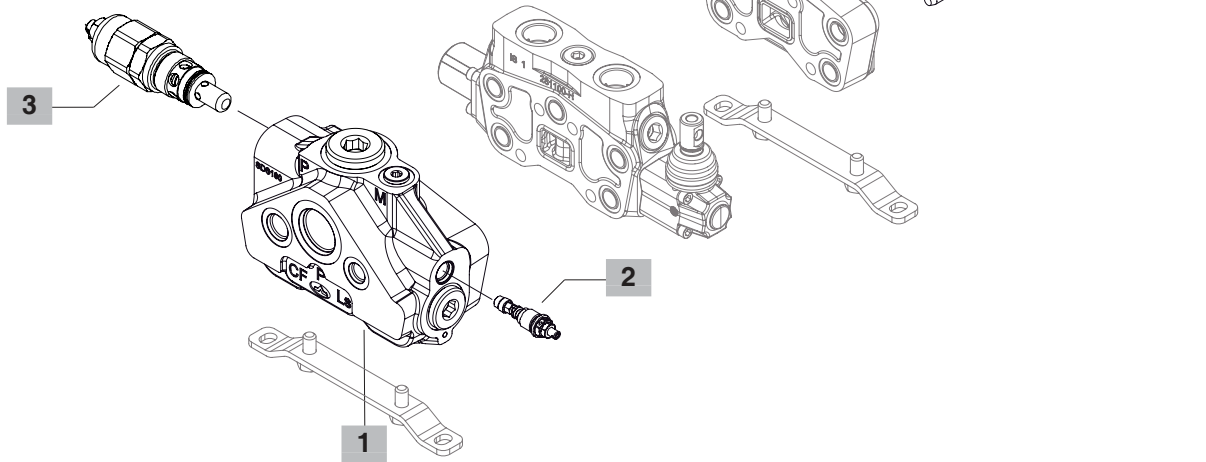

1 Inlet cover body * page 23

CODE: 5FIA118320
DESCRIPTION: Standard body

2 L.S. relief valve options page 23

Standard setting is referred to 10 l/min - 2.6 US gpm flow.

TYPE	CODE	DESCRIPTION
LS	XCAR126212	Range 40-180 bar / 580-2600 psi standard setting 90 bar / 1300 psi
	XCAR126214	Range 180-350 bar / 2600-5000 psi standard setting 180 bar / 2600 psi
LSD	XCAR126215	Range 40-180 bar / 580-2600 psi standard setting 90 bar / 1300 psi
	XCAR126213	Range 180-350 bar / 2600-5000 psi standard setting 180 bar / 2600 psi
LSH	XCAR126216	Range 40-180 bar / 580-2600 psi standard setting 90 bar / 1300 psi
	XCAR126217	Range 180-350 bar / 2600-5000 psi standard setting 180 bar / 2600 psi
LSZ	5CAR126218	Range 6-115 bar / 90-1650 psi standard setting 90 bar / 1300 psi
	5CAR126219	Range 130-350 bar / 1900-5000 psi standard setting 180 bar / 2600 psi
ST	5KIT126210	Relief valve blanking plug

3 Inlet relief valve options page 13

Standard setting is referred to 10 l/min - 2.6 US gpm flow.

TYPE	CODE	DESCRIPTION
SV	3XTAP535410	Relief valve blanking plug
VMP20/1 pilot operated pressure relief valve type X		
(XG-120)	X007211120	Range 60-250 bar / 900-3600 psi standard setting 120 bar / 1750 psi
(XGN-120)	XCAR120313	As previous without filter
VMD20/1 direct pressure relief valve type Y (standard)		
(YG2-80)	3XCAR120212	Range 63-125 bar / 900-1800 psi standard setting 80 bar / 1150 psi
(YG3-120)	3XCAR120213	Range 100-200 bar / 1450-2900 psi standard setting 175 bar / 2500 psi
(YG4-250)	3XCAR120214	Range 160-320 bar / 2300-4650 psi standard setting 250 bar / 3600 psi
Double stage relief valve (pilot port SAE 8)		
(XGD)	1130040408	Setting 207 and 235 bar / 3000 and 3400 psi

4 Assembling kit

CODE	DESCRIPTION
5TIR4161	Tie rod kit for 1 working sectional valve
5TIR4162	Tie rod kit for 2 working sectional valve
5TIR4163	Tie rod kit for 3 working sectional valve
5TIR4164	Tie rod kit for 4 working sectional valve
5TIR4165	Tie rod kit for 5 working sectional valve
5TIR4166	Tie rod kit for 6 working sectional valve
5TIR4167	Tie rod kit for 7 working sectional valve
5TIR4168	Tie rod kit for 8 working sectional valve
5TIR4169	Tie rod kit for 9 working sectional valve
5TIR416A	Tie rod kit for 10 working sectional valve

NOTE (*) - Codes are referred to **BSP** thread.

Configuration with priority valve

Dimensional data and hydraulic circuit

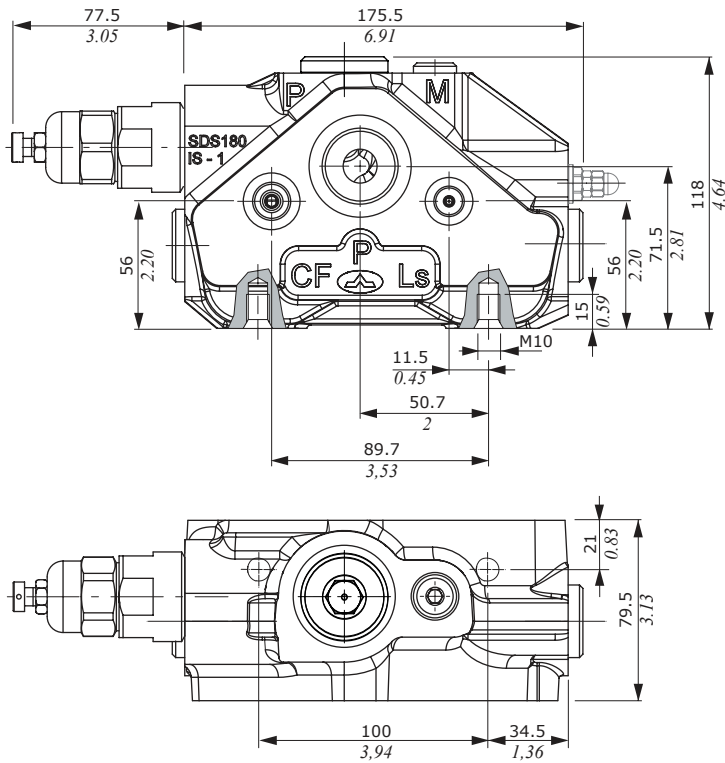

Load Sensing pressure relief valves

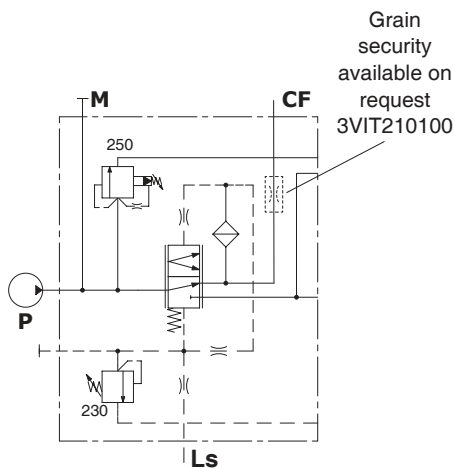
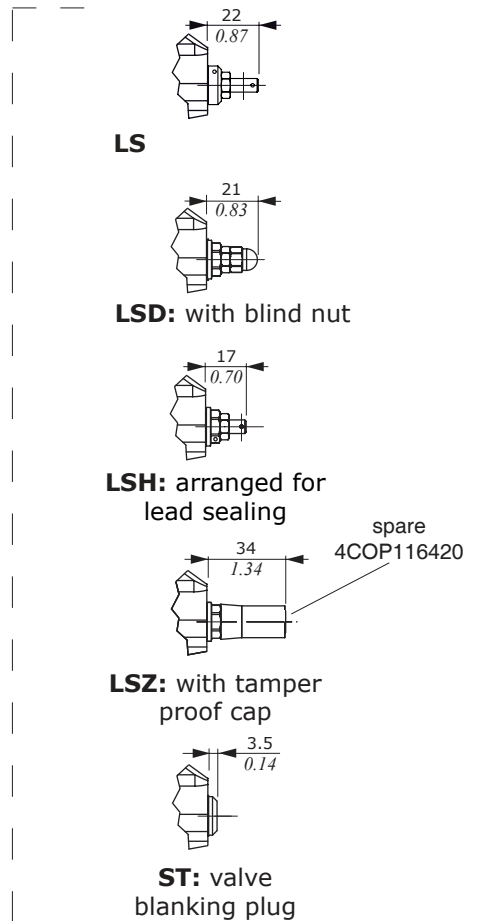

Stand-by pressure vs. regulated flow for various values of inlet flow

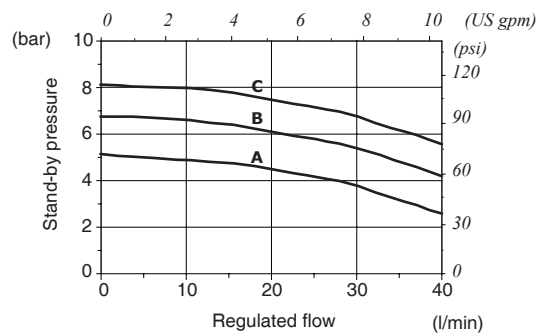

Configuration with unloader operation spool type

SDS180 / BCHW (LSW - 250) ELNW(NO) - 12VDC

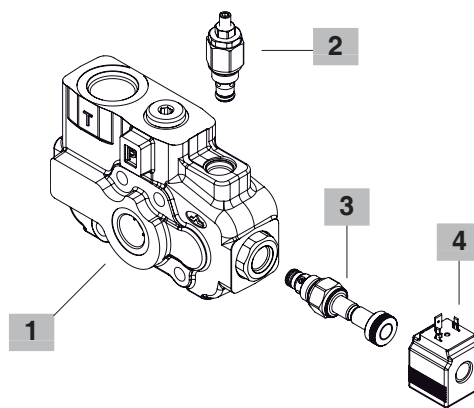
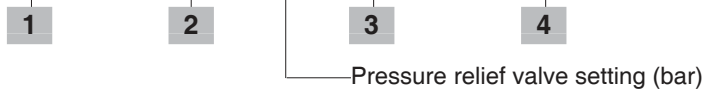

1 Inlet cover body * page 25

CODE: 5FIA118373
DESCRIPTION: with flow cut-out

2 Inlet relief valve options page 21

Standard setting is referred to 10 l/min - 2.6 US gpm flow.

TYPE	CODE	DESCRIPTION
SV	XTAP525320	Relief valve blanking plug
Main relief valve		
LSW(G2)FC07	5KIT118120	Range 5-50 bar / 72-720 psi standard setting 30 bar / 400 psi
LSW(G3)FC07	5KIT118121	Range 50-200 bar / 720-3200 psi standard setting 150 bar / 2150 psi
LSW(G4)FC07	5KIT118122	Range 180-315 bar / 2600-4550 psi standard setting 250 bar / 3600 psi

3 Pilot solenoid valve options page 21

TYPE	CODE	DESCRIPTION
ELNW(NO)	0EF08002000	Without manual emergency, NO circuit
ELNW(NC)	0EF08002001	Without manual emergency, NC circuit
ELTW(NO)	0EF08002004	"Push&twist" manual emergency, NO circuit
ELPW(NO)	0EF08002002	Push-button manual emergency, NO circuit
ELVW(NO)	0EF08002003	Screw type manual emergency, NO circuit

4 Coils page 70

TYPE	CODE	DESCRIPTION
12VDC	4SLE001200	Coil BER 12VDC-ISO4400

For complete available coils list see page 70

NOTE (*) - Codes are referred to **BSP** thread.

Configuration with unloader operation spool type

Dimensional data and hydraulic circuit

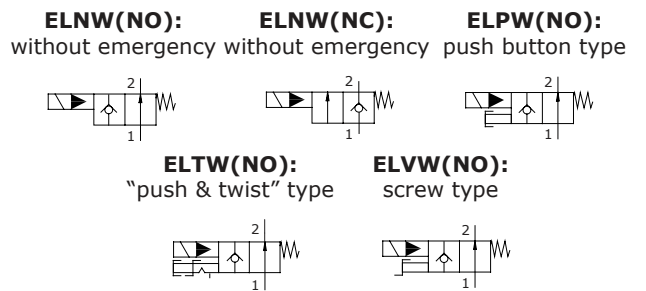
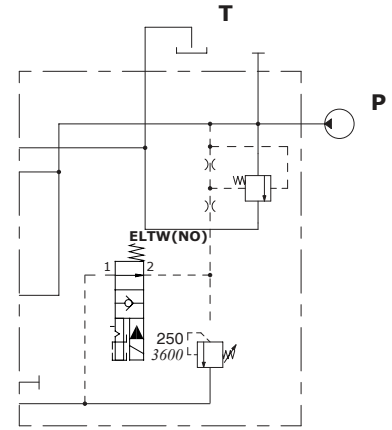
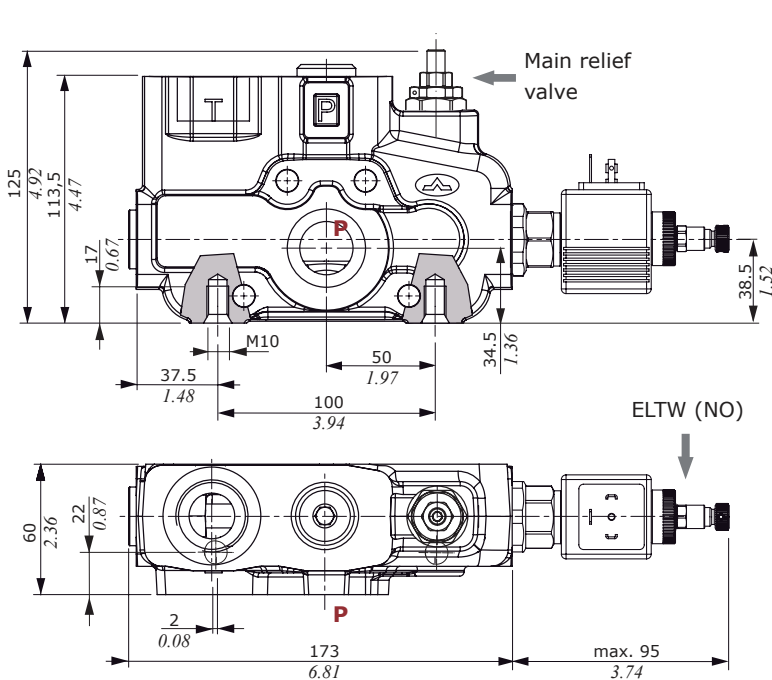

Main relief valve diagrams

Type (G2) setting range

From 5 to 50 bar / from 72 to 720 psi

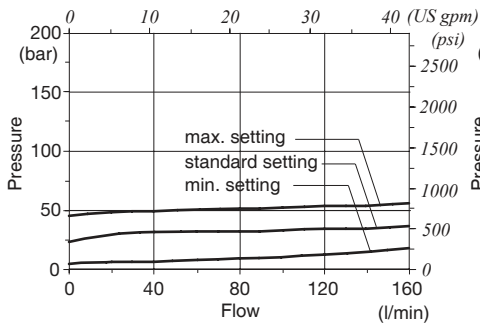

Type (G3) setting range

From 50 to 200 bar / from 720 to 2900 psi

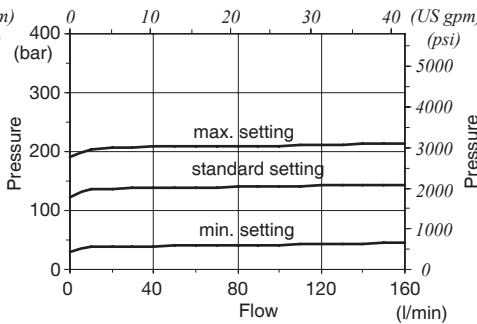

Type (G4) setting range

From 180 to 315 bar / from 2600 to 4550 psi

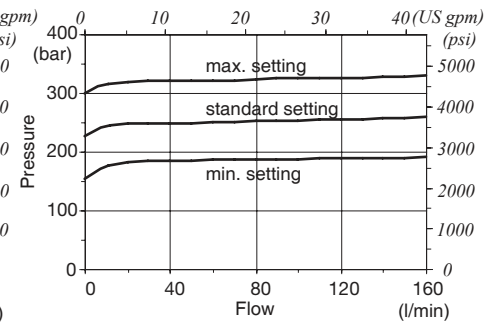

Pressure drop P ⇒ T on SDS 180/4

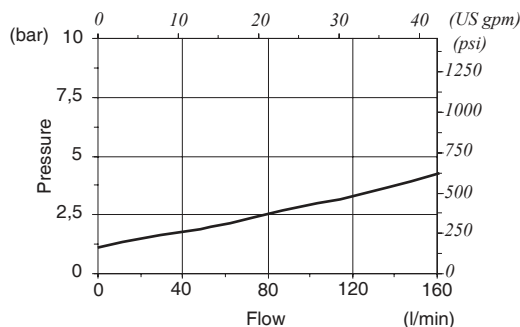

Parts ordering codes (mechanical control)

EL SDS180 / P - 1 8 L . P1 (G3 - 100)

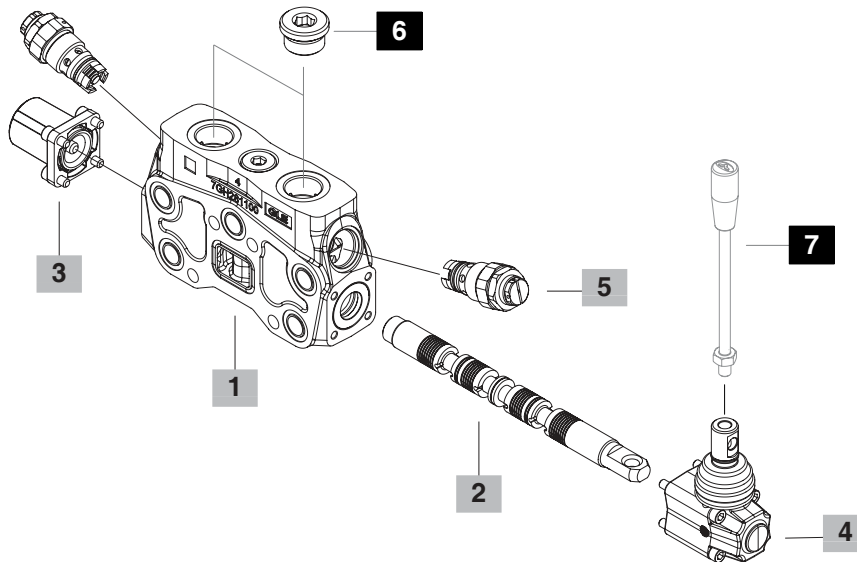

1 Working section kit * page 29

TYPE	CODE	DESCRIPTION
P	5EL1183000	Per circuito parallelo
	5EL1183000C	For parallel circuit, for automatic release positioner (11A)
SP	5EL3183001	For tandem circuit
S	5EL2163000	For series circuit
P5	5EL1183201	For parallel circuit and floating circuit
PES	5EL1163000	For parallel circuit, for valve with series circuit (page 8)
PHT	5EL1183080	Need spools 1TX and 1TYD
PHD	5EL1183020	Need spools 1CSG and 1CSGH

2 Spools** page 30

TYPE	CODE	DESCRIPTION
1	3CU2510100	Double acting, 3 positions, with A and B closed in neutral position
1(11A)	3CU2510321	As previous, for automatic release positioner type 11A
1CS	3CU2510200	As type 1, sensitive type
1CSG	3CU2510250	Double acting with A and B closed in neutral position, B partially connect to tank in pos.1, A partially connect to tank in pos.2 for section kit PHD
1CSGH	3CU2510251	As previous, sensitive type for section kit PHD
1A	3CU2521100	Double acting, 3 positions, with A open to tank in neutral position
1B	3CU2522100	Double acting, 3 positions, with B open to tank in neutral position

2 Spools (continued)** page 30

TYPE	CODE	DESCRIPTION
1D	3CU2510210	As type 1, sensitive type for flow up to 100 l/min - 26,42 USgpm
1TX	3CU2510601	Double acting with A and B closed in neutral pos. with restricted connection to tank for section kit PHT
1TYD	3CU2510603	As previous, B with restricted connection to tank for section kit PHT
2	3CU2525100	Double acting, 3 positions, with A and B open to tank in neutral position
2H	3CU2525225	Double acting 3 positions, with A and B partially open to tank in neutral position
3	3CU2531100	Single acting on A, 3 positions, B plugged; requires G3/4 plug
4	3CU2535100	Single acting on B, 3 positions, A plugged; requires G3/4 plug
5	3CU2541200	Double acting spool with A and B closed in neutral position, 4 positions, with spool in, floating 4 th position: need dedicated positioner kit type 13MD
5B	3CU2541203-H	Double acting spool with A and B closed in neutral position, 4 positions, with spool out, floating 4 th position: need dedicated positioner kit type 13C
8PF	3CU2561210	Double acting 3 positions, regenerative circuit in 3 rd position with spool in: need dedicated positioner kit
8PFG	3CU2561215	Double acting 3 positions, regenerative circuit in 3 rd position with spool out: need dedicated positioner kit

NOTE (*) – Codes are referred to **BSP** thread.

(**) For special features of the various spools please contact Sales Dpt.

Parts ordering codes (mechanical control)

3 "A" side spool positioners page 32		
TYPE	CODE	DESCRIPTION
8	5V08110000	With spring return in neutral position
8TL	5V08110310	As type 8, for flexible cable control
8F2	5V08110101	As type 8 with adjustable stroke limiter
11	5V11110000	Detent in positions neutral, 1 and 2
12	5V12110000	Detent in positions 1 and 2
15	5V15110000	2 positions, detent in pos. 1 and neutral
16	5V16110000	2 positions, detent in pos. 2 and neutral
9BZ	5V09110030	With detent in position 1 and spring return in neutral position
10BZ	5V10110030	With detent in position 2 and spring return in neutral position
11BZ	5V11110030	Detent in positions 1 and 2 and spring return in neutral position
8MG3	5V08110050	As type 8, operation with microswitch (NO) in positions 1 and 2
8MG19/29(NO)	5V08110080	As type 8, operation with 2 microswitch (NC) in positions 1 and 2
8RMN2	5V08416030	12 VDC with electromagnetic detent
	5V08416040	24 VDC with electromagnetic detent
8K	5V08710112	As type 8 and 12 VDC solenoid lock device
	5V08710124	As previous, 24 VDC
8PDG	5V08110710	ON/OFF pneumatic waterproof kit
8PG	5V08110708	ON/OFF pneumatic kit
8EPDG3	5V08110740	12 VDC ON/OFF pneumatic waterproof kit
	5V08110738	24 VDC ON/OFF pneumatic waterproof kit
8EPG3	5V08110725	12 VDC ON/OFF electro-pneumatic kit
	5V08110726	24 VDC ON/OFF electro-pneumatic kit
8EI3	5V08110320	12 VDC ON/OFF electro-hydraulic kit
	5V08110321	24 VDC ON/OFF electro-hydraulic kit
11A	5V11510110	With detent in pos. 1 and 2, automatic release in neutral position: need dedicated spool 3CU2510321
13MD	5V13416010	4 pos. Detent in 4th position with spring return in neutral position with detent pull type. Needs spool type 5
13C	5V13116005	4 pos. Detent in 4th position with spring return in neutral position with detent push type. Needs spool type 5B

Positioner kit for **8PF** and **8PFG** regenerative spools:

Overall dimensions are the same ones as those of standard controls listed above.

8CR	5V08110020	With spring return in neutral position
9BCR	5V09110020	With detent in position 1 and spring return in neutral position
8PGCR	5V08110706	ON/OFF pneumatic kit
8EPG3CR	5V08110727	12 VDC electro-pneumatic kit ON/OFF
	5V08110728	24 VDC electro-pneumatic kit ON/OFF
8EI3CR	5V08110357	12 VDC electro-hydraulic kit ON/OFF
	5V08110353	24 VDC electro-hydraulic kit ON/OFF

4 "B" side options page 40		
TYPE	CODE	DESCRIPTION
L	5LEV110000	Standard lever box
LF1	5LEV110101	Lever box with spool stroke limiter in position 1
LB	5LEV310000	Steel lever
LCB	5CLO216100	Joystick lever for 2 sections operation
LCE	5CLO216050	As previous with bronze support
SL	--	Without lever box
SLP	5COP110000	Without lever box, with dust-proof plate
TQ	5TEL110110	Flexible cable connection; for CD cables

5 Port relief valves page 46

Valves standard setting is referred to 10 l/min - 2.64 USgpm flow.

TYPE	CODE	DESCRIPTION
P3T	XTAP530361	A and B ports valve blanking plugs
C	3XCAR416100	Anti-cavitation valve
Anti-shock valve		
P(G2)	XCAR216115	Range 50-120 bar / 725-1750 psi standard setting 63 bar / 900 psi
P(G3)	XCAR216116	Range 100-250 bar / 1450-3600 psi standard setting 100 bar / 1450 psi
P(G4)	XCAR216117	Range 160-315 bar / 2300-4600 psi standard setting 200 bar / 2900 psi

Pilot hydraulic unloader valve

PX	XCAR416301	Pilot hydraulic unloader valve
-----------	------------	--------------------------------

Anti-shock and anti-cavitation valve

U(G2)	X011411099	Range 35-90 bar / 510-1300 psi standard setting 60 bar / 870 psi
U(G3)	X011411100	Range 100-250 bar / 1450-3600 psi standard setting 100 bar / 1800 psi
U(G4)	X011411101	Range 180-350 bar / 2600-5100 psi standard setting 200 bar / 2900 psi

Pilot operated anti-shock and anti-cavitation valve

UXW(G)	X01141B160	Range 63-315 bar / 900-4600 psi standard setting 160 bar / 2300 psi
---------------	------------	--

6 Port plugs *

CODE	DESCRIPTION
3XTAP732200	G3/4 Plug

7 Optional hand levers

TYPE	CODE	DESCRIPTION
AL01/M10x200	170012020	For L lever box L= 200 mm / 7.87 in
AL08/M12x250	170013125	For LCB joystick L= 250 mm / 9.84 in

NOTE (*) - Codes are referred to **BSP** thread

Parts ordering codes (proportional hydraulic control)

EL SDS180 / P - 1IM 8IM . U1 (G3 - 100)

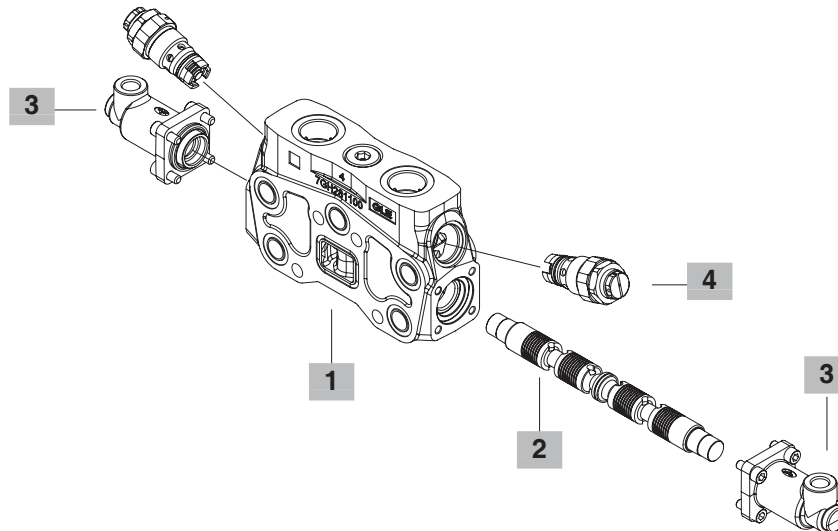

1 Working section kit * page 29

TYPE	CODE	DESCRIPTION
P/IM	5EL1183000A	With parallel circuit
P5/IMP	5EL1183205A	As previous for floating circuit: need spool type 5IMP and complete controls 13IMP
SP/IM	5EL3183001B	With tandem circuit
SP5/IM	5EL3183202	As previous for floating circuit
PHD/IM	5EL1183020A	Need spool 1IMDA

2 Spools page 30

TYPE	CODE	DESCRIPTION
1IM	3CU2510420	Double acting with A and B closed in neutral position
1IMDA	3CU2510490	Descent control and load check valve without power supply on port "A": need working section PHD/IM and control type 8IMD
1AIM	3CU2522420	Double acting with A open to tank in neutral position
1BIM	3CU2522420	Double acting with B open to tank in neutral position
2H	3CU2525425	As type 2 with A and B partially connect to tank in neutral position
2IM	3CU2525420	Double acting with A and B connect to tank in neutral position
3IM	3CU2535420	Single acting on A, B plugged
4IM	3CU2535420	Single acting on B; A plugged
5IMP	3CU2542430	Double acting spool with A and B closed in neutral position, spool out floating 4 th position: need working section P5/IMP and control type 13 IMP
1IM (8IMSP)	3CU2510491	As type 1M: need control type 8IMSPSL4P

3 Complete controls * page 43

TYPE	CODE	DESCRIPTION
8IM	5IDR216300	Zama control kit for special spools and body kit without seals and ring. Range 5.8-19 bar / 84-270 psi
8IMD	5IDR218300	Control kit with floating circuit and PHD section. Range 5.8-19 bar 84-270 psi: need working section PHD/IM and spool type 1IMDA
8IMF3	5IDR216303	Zama control kit with screws spool stroke adjusting. Range 5.8-19 bar 84-270 psi
8IMSPSL4P	5IDR218012	Zama control kit with spool position sensor. Range 0.8-4.2 bar / 11-60 psi: need spool type 1IM(8IMSP)
8IMOH	5IDR216000-H	Steel control kit. Range 5.8-19 bar 84-270 psi
13IMP	5IDR216014	Control kit for floating circuit. Range 5.8-14 bar / 84-270 psi: need working section P5/IMP spool type 5IMP

4 Port valves page 46

See page 27.

NOTE (*) – Codes are referred to **BSP** thread.

Dimensional data and hydraulic circuit

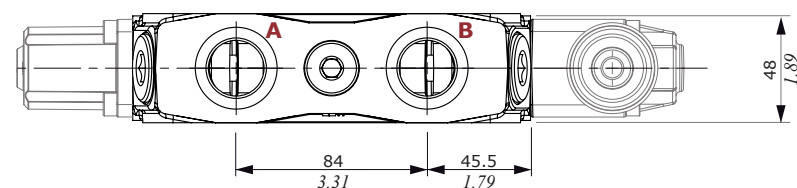
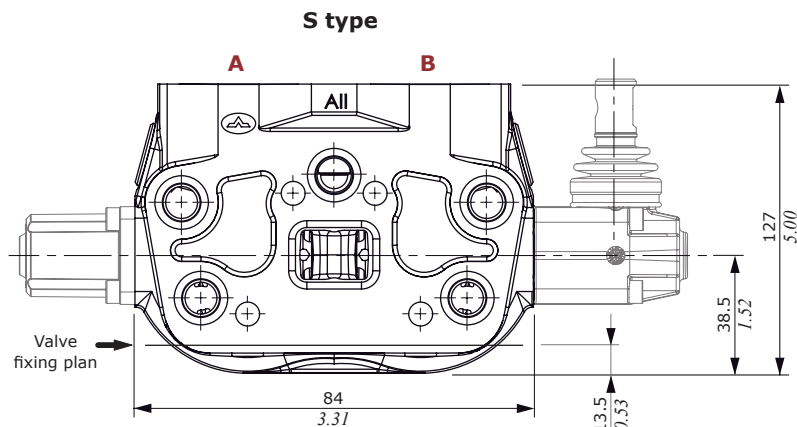
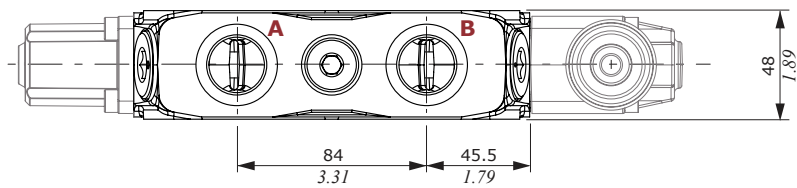
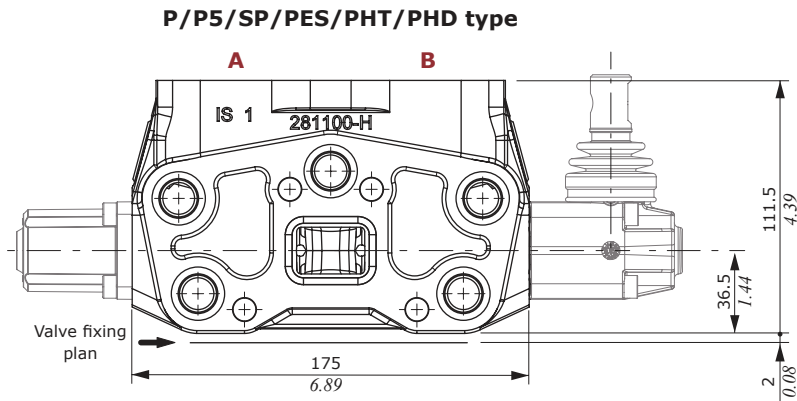

P/P5/PHT/PHD type

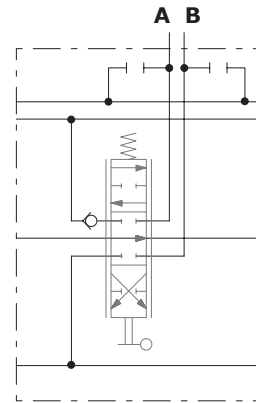

SP type

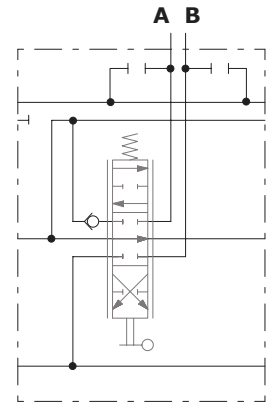

PES type

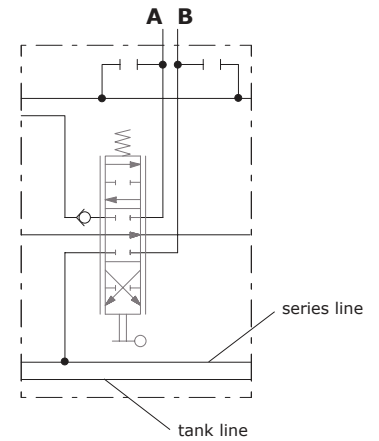

S type

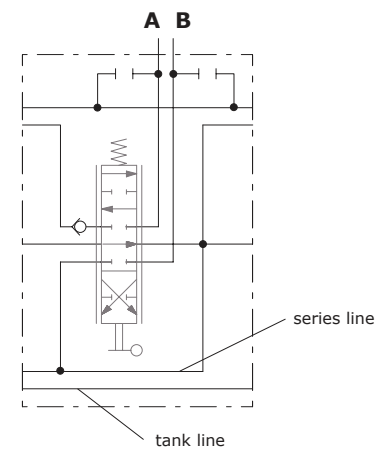

Spools

Spool type 1 (1D/1CS/1[11A]/1IM)

Double acting, 3 positions, with A and B closed in neutral position

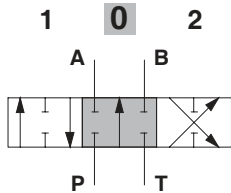

Spool stroke

position 1: + 7 mm (+ 0.28 in)
position 2: - 7 mm (- 0.28 in)

Spool metering type 1

$Q_{in} = 160 \text{ l/min} / (42 \text{ US gpm})$

$P_{(on ports)} = 100 \text{ bar} / (1450 \text{ psi})$

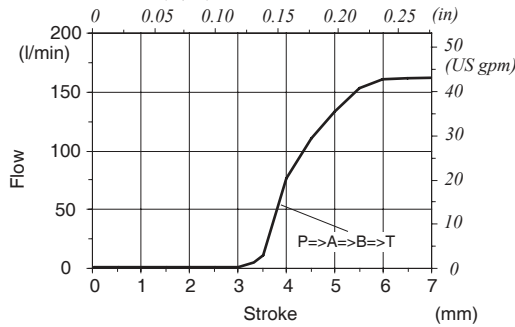

Spool type 2 (2IM)

Double acting, 3 positions, with A and B open to tank in neutral position

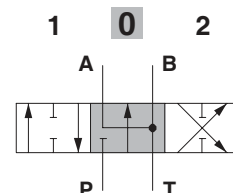

Spool stroke

position 1: + 7 mm (+ 0.28 in)
position 2: - 7 mm (- 0.28 in)

Spool type 1A (1AIM)

Double acting, 3 positions, with A open to tank in neutral position

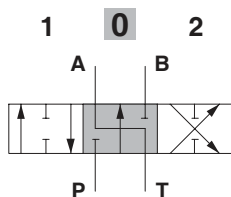

Spool stroke

position 1: + 7 mm (+ 0.28 in)
position 2: - 7 mm (- 0.28 in)

Spool type 1B (1BIM)

Double acting, 3 positions, with B open to tank in neutral position

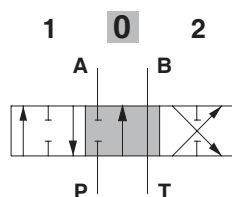

Spool stroke

position 1: + 7 mm (+ 0.28 in)
position 2: - 7 mm (- 0.28 in)

Spool type 2H

Double acting, 3 positions, with A and B partially open to tank in neutral position

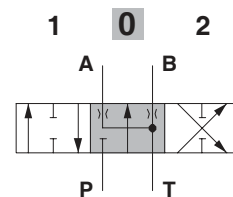

Spool stroke

position 1: + 7 mm (+ 0.28 in)
position 2: - 7 mm (- 0.28 in)

Spool type 3 (3IM)

Single acting on A, 3 positions, B plugged; requires G3/4 plug

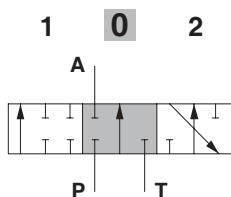

Spool stroke

position 1: + 7 mm (+ 0.28 in)
position 2: - 7 mm (- 0.28 in)

Spool type 4 (4IM)

Single acting on B, 3 positions, A plugged; requires G3/4 plug

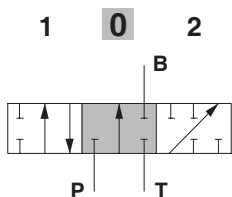

Spool stroke

position 1: + 7 mm (+ 0.28 in)
position 2: - 7 mm (- 0.28 in)

Spool type 5B

Double acting spool with A and B closed in neutral position, 4 positions, with spool out, floating 4th position

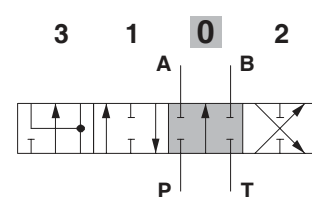

Spool stroke

position 1: + 6 mm
position 2: - 6 mm
position 3: + 12 mm

Spool type 5 (5IMP)

Double acting spool with A and B closed in neutral position, 4 positions, with spool in, floating 4th position

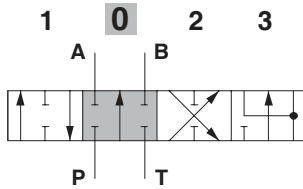

Spool stroke

position 1: + 6 mm (+ 0.24 in)
position 2: - 6 mm (- 0.24 in)
position 3: - 12 mm (- 0.47 in)

Spool metering

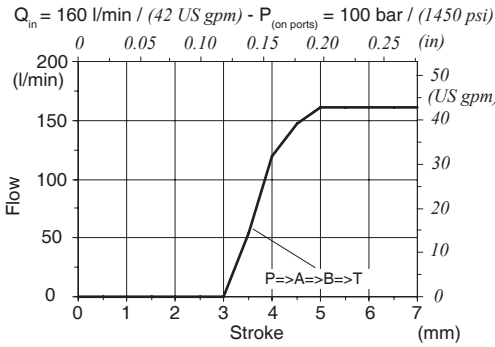

Pressure drop in position 3

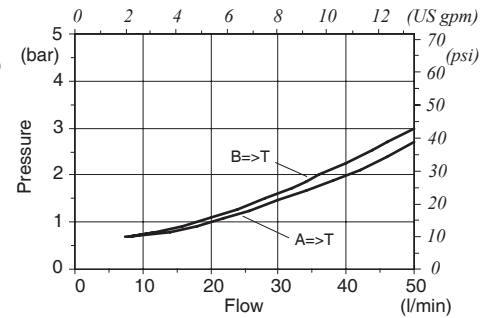

Spool type 8PF

Double acting, 3 positions, regenerative circuit in 3rd position with spool in

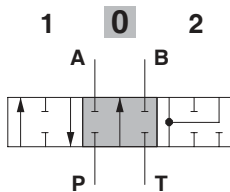

Spool stroke

position 1: + 5.7 mm (+ 0.22 in)
position 2: - 5.7 mm (- 0.22 in)

Spool metering

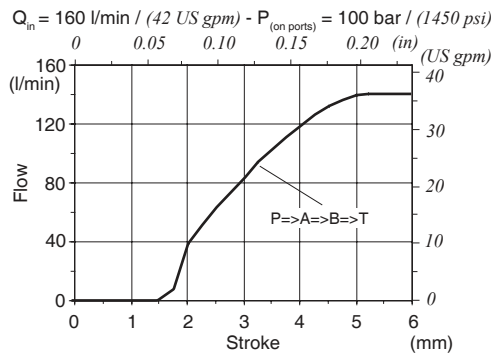

Pressure drop

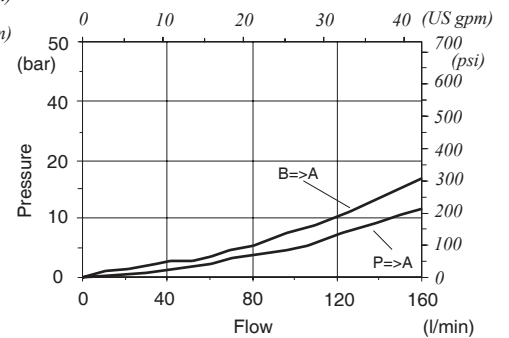

Spool type 8PFG

Double acting, 3 positions, regenerative circuit in 3rd position with spool out

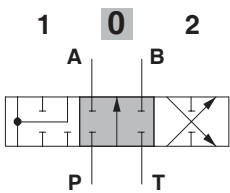

Spool stroke

position 1: + 5.7 mm (+ 0.22 in)
position 2: - 5.7 mm (- 0.22 in)

Spool type 1CSG (1CSGH)

Double acting with A and B closed in neutral position, B partially connect to tank in pos. 1, A partially connect to tank in pos. 2

Spool type 1TX (1TYD)

Double acting with A and B closed in neutral position with restricted connection to tank

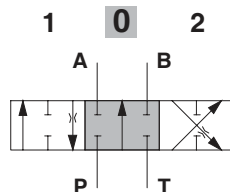

Spool stroke

position 1: + 7 mm (+ 0.28 in)
position 2: - 7 mm (- 0.28 in)

Spool type 1IMDA

Descent control and load check valve without power supply on port "A"

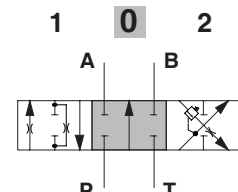

Spool stroke

position 1: + 7 mm (+ 0.28 in)
position 2: - 7 mm (- 0.28 in)

"A" side spool positioners

With spring return

Type 8

It's supplied with standard spring type D (see force-stroke diagram) and available with lighter spring type C (SMC code: 5V08210000).

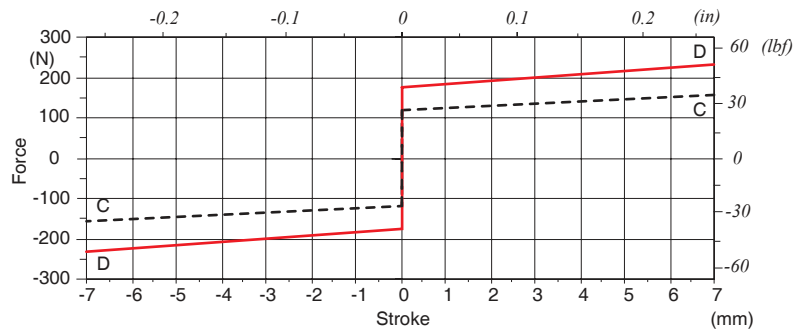
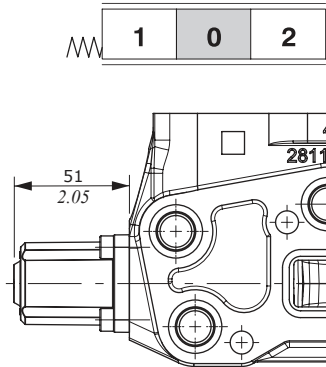

Type 8TL

As type 8, for flexible cable control.

Type 8F2

With spool stroke adjustment in position 2 (P ⇒ B).

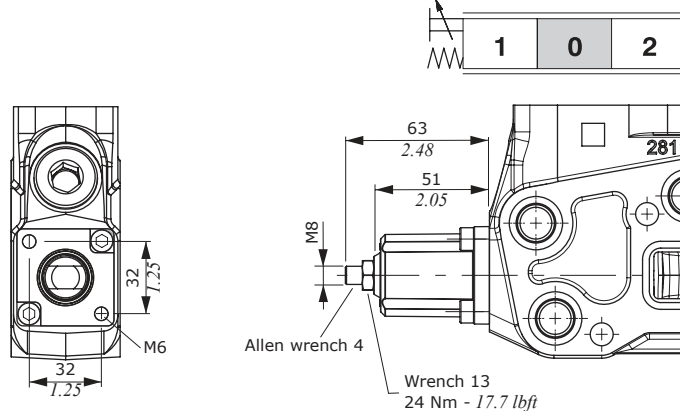
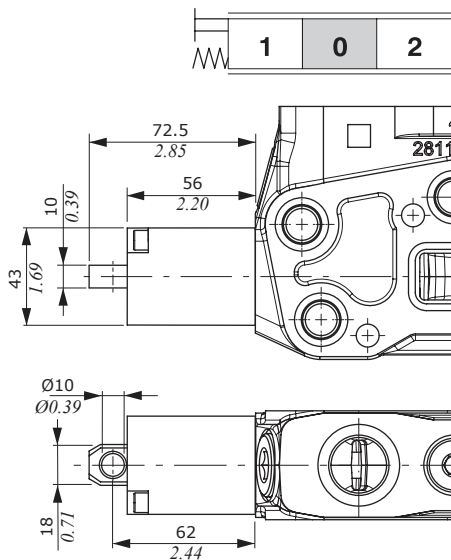

With detent

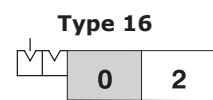
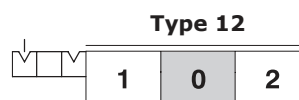
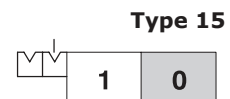
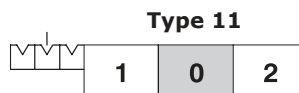
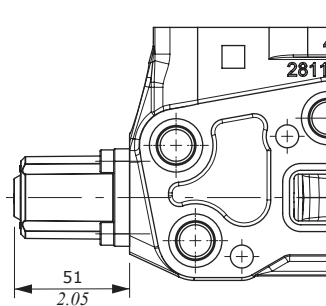

Features

Detent and release force : 280 N / 63 lbf ±10%

“A” side spool positioners

With detent and spring return to neutral position from either directions

Type 9BZ

detent in position 1 (curve A)



Type 10BZ

detent in position 2 (curve B)



Type 11BZ

detent in position 1 and 2 (curves A and B)

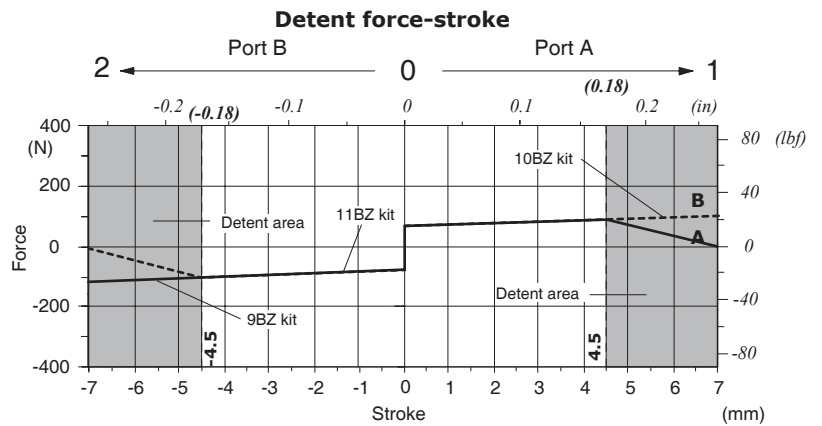
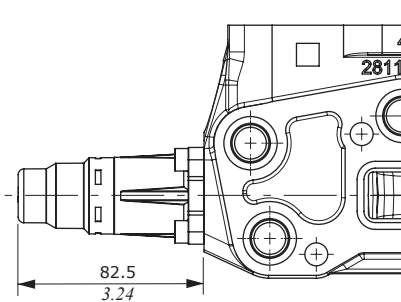

Position 1 - Detent force: 130 N / 29.2 lbf ± 10% / Release force: 215 N / 48.3 lbf ± 10%
Position 2 - Detent force: 145 N / 32.6 lbf ± 10% / Release force: 300 N / 67.4 lbf ± 10%

Solenoid lock device type 8K

With spring return and spool electromechanical lock in neutral position; when coil is fed the spool can be moved. it's possible to obtain further configurations with several “A” side spool positioners: contact Sales Dept.

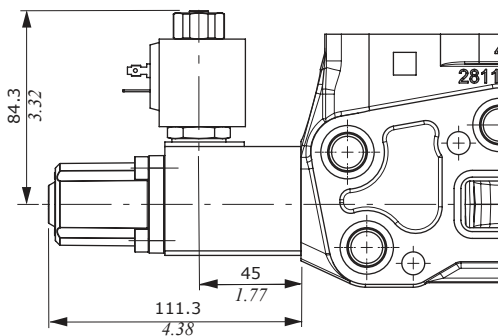
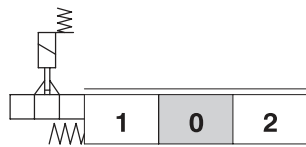

For coil **BE** and mating connectors see page 70

“A” side spool positioners

With microswitch

Type 8MG3

With spring return in neutral position and microswitch operated in both directions. Also available **8MG1** (microswitch operated in position 1) and **8MG2** (microswitch operated in position 2) configurations; dimension are the same of **8MG3** configuration.
 Note: this control is not compatible with valves on port “A”.

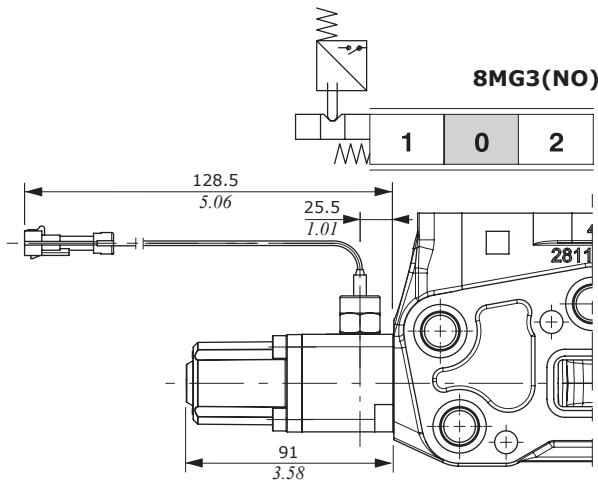

Circuit	Complete controls		
	Microswitch operation		
	position 1 8MG1	position 2 8MG2	positions 1, 2 8MG3
(NO)	5V08110060	5V08110070	5V08110050
(NC)	/	/	5V08110053

Features

- MICROSWITCH
- Mechanical life : 5x10⁵ operations
- Electrical life (resistive load) .. : 10⁵ oper. – 7A / 13.5VDC
 : 5x10⁴ oper. – 10A / 12VDC
 : 5x10⁴ oper. – 3A / 28VDC
- Connector : Packard Weather-pack
- Mating connector cod. 5CON001 not included

Type 8MG19/MG29

With double microswitch in position 1 and 2.

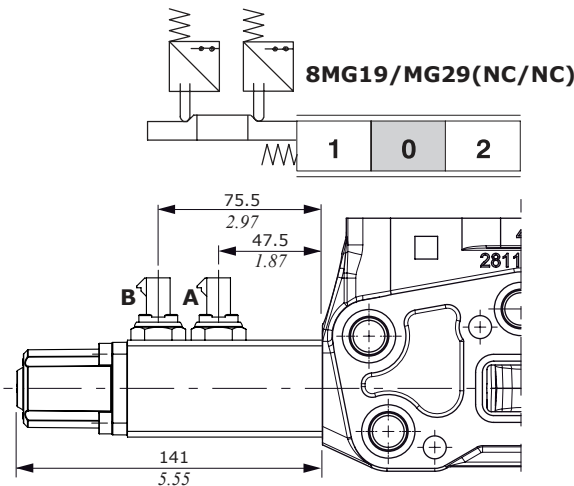

Positions	A	B
1	↗ •	• ↘
0	• •	• •
2	• •	↙ •

Features

- MICROSWITCH
- Mechanical life : 5X10⁵ operations
- Electrical life (resistive load) .. : 10⁵ oper. – 7A / 13.5VDC
 : 5x10⁴ oper. – 10A / 12VDC
 : 5x10⁴ oper. – 3A / 28VDC
- Connector : Packard Weather-pack
- Mating connector cod. 5CON140047 not included

Electromagnetic detent type 8RMN2

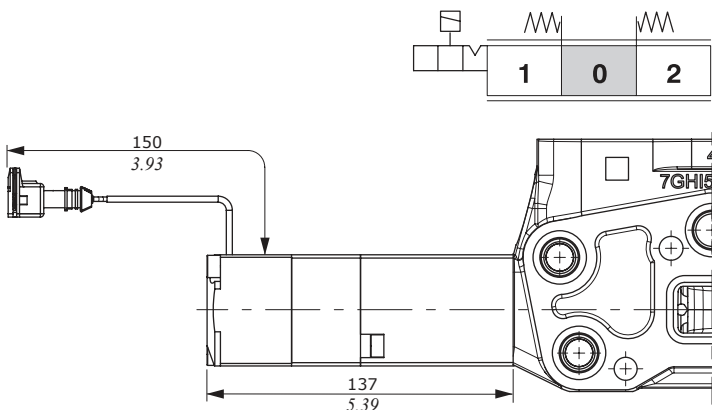

Features

- Nominal voltage : 12-24 VDC (± 10%)
- Power rating : 5 W
- Resitance : 26-29.8 Ω - 12VDC
 : 102-118 Ω - 24VDC
- Duty cycle : 100%
- Connector : AMP JPT 2P
- Unlocking force (12 VDC) : 380N - 85.4 lbf
- Mating connector cod. W0251001 not included

"A" side spool positioners

ON/OFF pneumatic kit type 8PG

With spring return to neutral position.

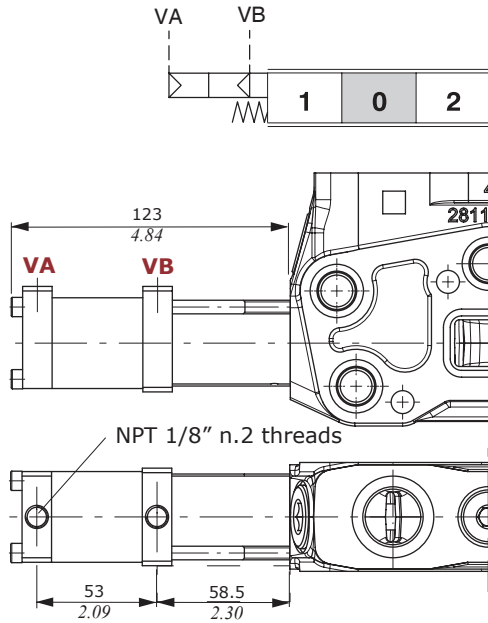

Features

Pilot pressure..... : min. 6 bar / 87 psi
 : max. 12 bar / 174 psi

ON/OFF electro-pneumatic kit type 8EPG3

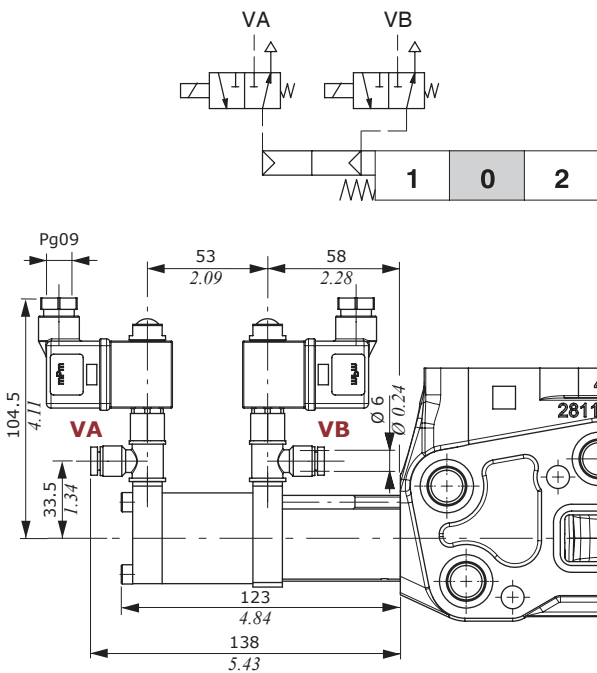

Features

Pilot pressure..... : min. 6 bar / 85 psi
 : max. 15 bar / 215 psi

For coil **BPV** see page 72

"A" side spool positioners

ON/OFF pneumatic waterproof kit type 8PDG

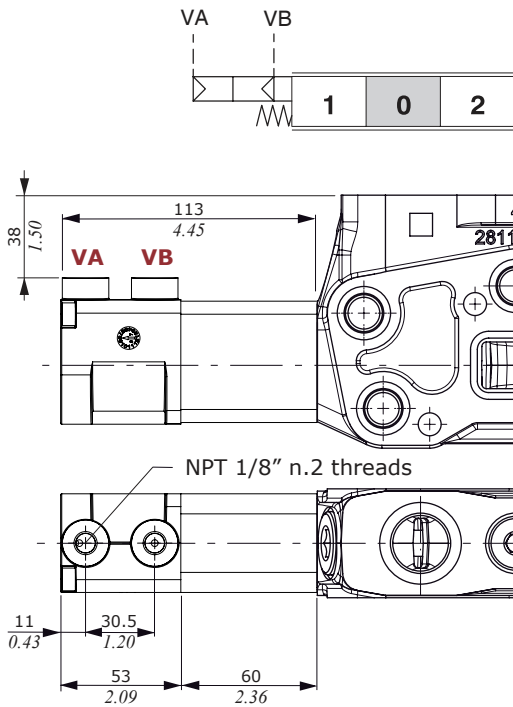

Features

Pilot pressure..... : min. 6.5 bar / 90 psi
 : max. 15 bar / 200 psi

ON/OFF electro-pneumatic waterproof kit type 8EPDG3

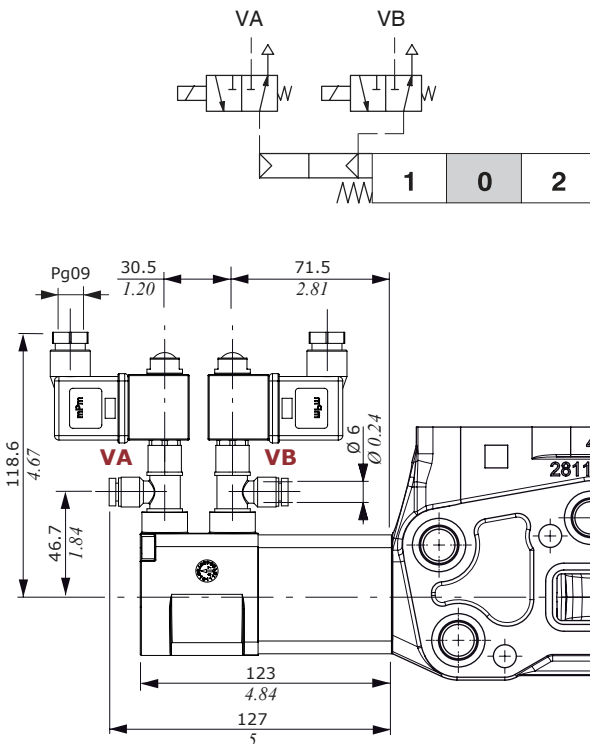

Features

Pilot pressure..... : min. 10 bar / 145 psi
 : max. 50 bar / 725 psi
 Max backpressure on drain L... : 25 bar / 360 psi
 For coil **BPV** see page 72

"A" side spool positioners

ON/OFF electro-hydraulic control 8EI3

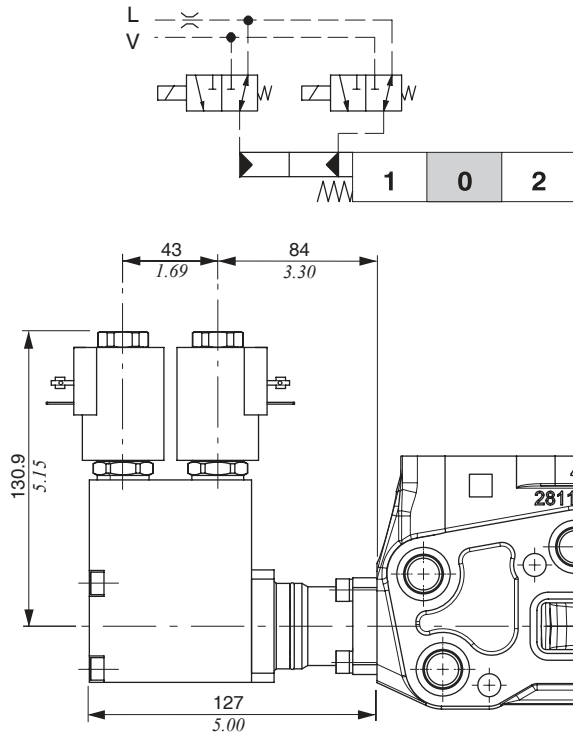

Features

Pilot pressure..... : min. 10 bar / 145 psi
 : max. 50 bar / 725 psi
 Max backpressure on drain L... : 25 bar / 360 psi
 For coil **BT** and mating connectors see page 71

Collector kit for external pilot and drain

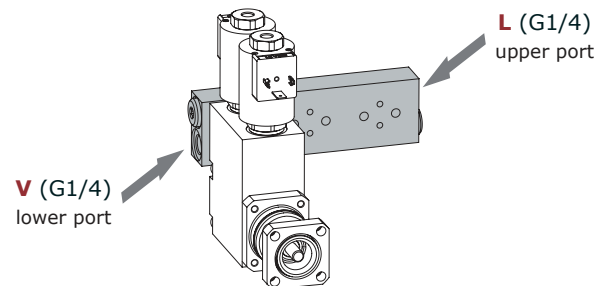
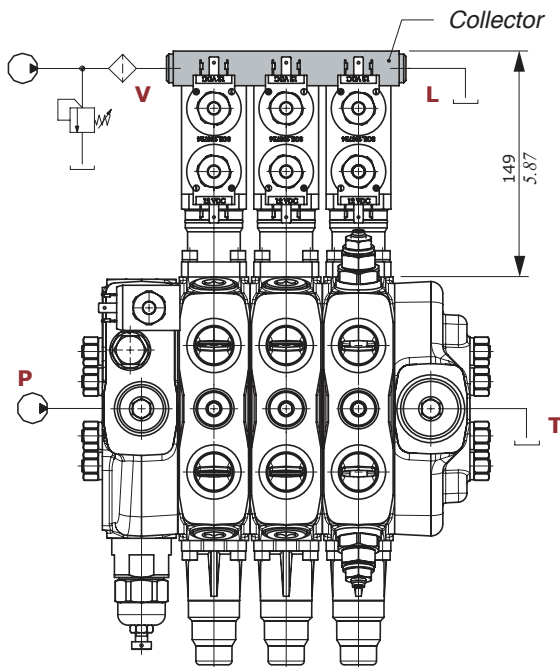

Description example:
 SDS180/3/AC(XG-210)R2E/18EI3LCZ/18EI3LCZ/
 18EI3LCZ.UX3(G-230)/RC-KE3S0-12VDC

COLLECTOR KIT CODES		
Type	Code *	Description
KE1S0	5KE1S00030	Kit for one section
KE2S0	5KE2S01530	Kit for 2 sections
KE3S0	5KE3S01530	Kit for 3 sections
KE4S0	5KE4S01530	Kit for 4 sections
KE5S0	5KE5S01530	Kit for 5 sections
KE6S0	5KE6S01530	Kit for 6 sections
KE7S0	5KE7S01530	Kit for 7 sections

(*) codes are referred to BSP thread

“A” side spool positioners

ON/OFF electro-hydraulic kit type 8EI3

Collector kit for internal pilot and drain

The kit include collector, VRP pressure reducing valve and pipes.

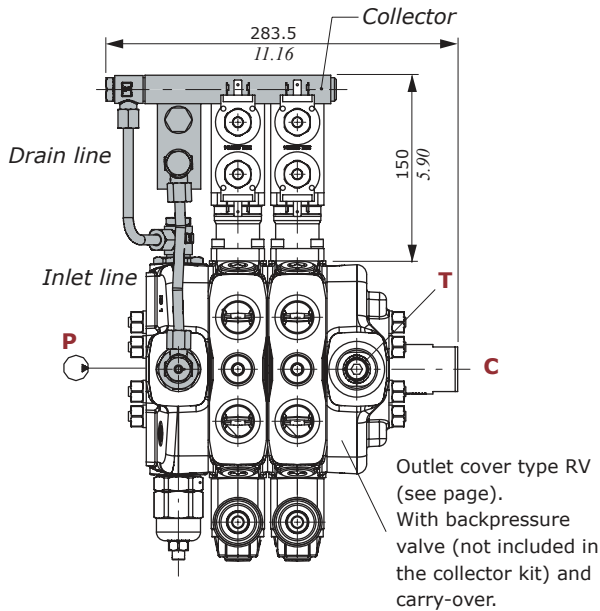

COLLECTOR KIT CODES		
Type	Code *	Description
KE1R3	5KE1R31530	Kit for one section
KE2R3	5KE2R31530	Kit for 2 sections
KE3R3	5KE3R31530	Kit for 3 sections
KE4R3	5KE4R31530	Kit for 4 sections
KE5R3	5KE5R31530	Kit for 5 sections
KE6R3	5KE6R31530	Kit for 6 sections
KE7R3	5KE7R31530	Kit for 7 sections

(*) codes are referred to BSP thread

Description example:
 SDS180/2/AC(YG3-120)/1CS8EI3L/1CS8EI3L/
RV-KE2R3-24VDC

Features

VRP VALVE

Output pressure. : 20 bar / 290 psi
 Max flow : 8 l/min / 2.1 US gpm
 Filtering : 80 μ

VRE backpressure valve

Valve assembled on flow through passage to provide pilot pressure to the actuator.
 It's available as **VRE** (code X076700010) or **VRE(6)** (code X076710006): see diagram.

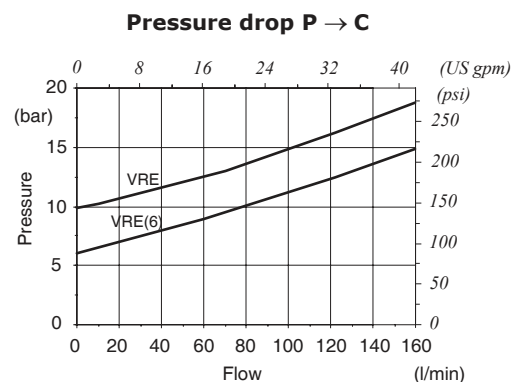
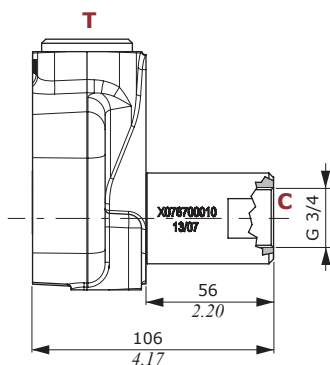

"A" side spool positioners

Particular positioner kits for special spools

11A

With detent in position 1 and 2, and automatic release in neutral position.
Need special body kit and dedicated spool 3CU2510321.

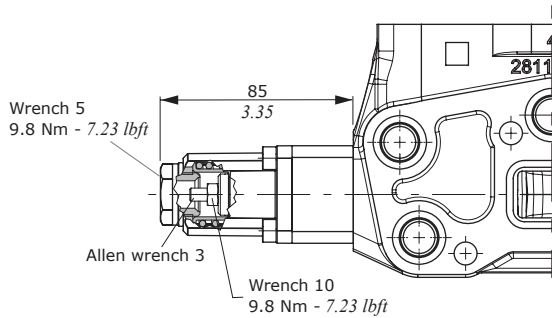
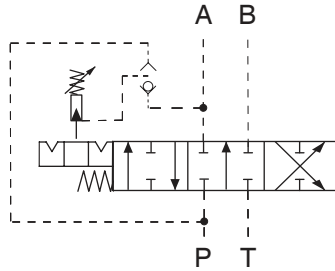

Special working section kit
5EL118300C

Features

Release pressure : from 20 to 180 bar
from 290 to 2600 psi

13MD

Detent in 4th position with spring return in neutral position with detent pull type. Needs spool type 5.

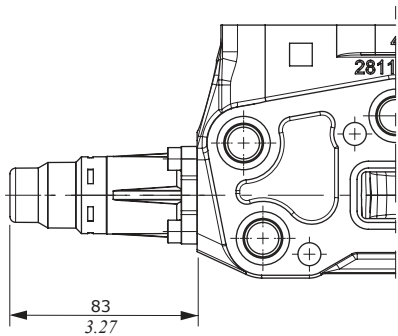
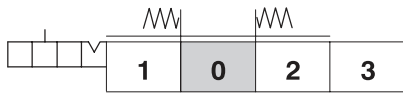

Special working section
5EL1183201 (left inlet)
5EL1183260 (right inlet)

13C

Detent in 4th position with spring return in neutral position with detent push type. Needs spool type 5B.

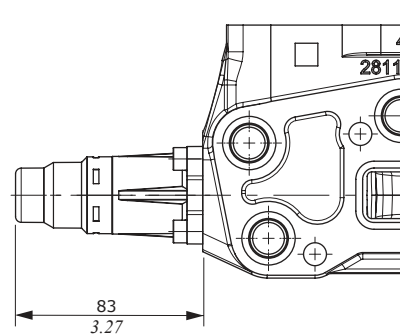
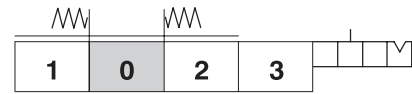

Special working section
5EL1183260 (left inlet)
5EL1183201 (right inlet)

"B" side options

Lever control

L Type

Alluminium lever pivot box with protective rubber bellow; it can be roated 180° (configuration **L180**).

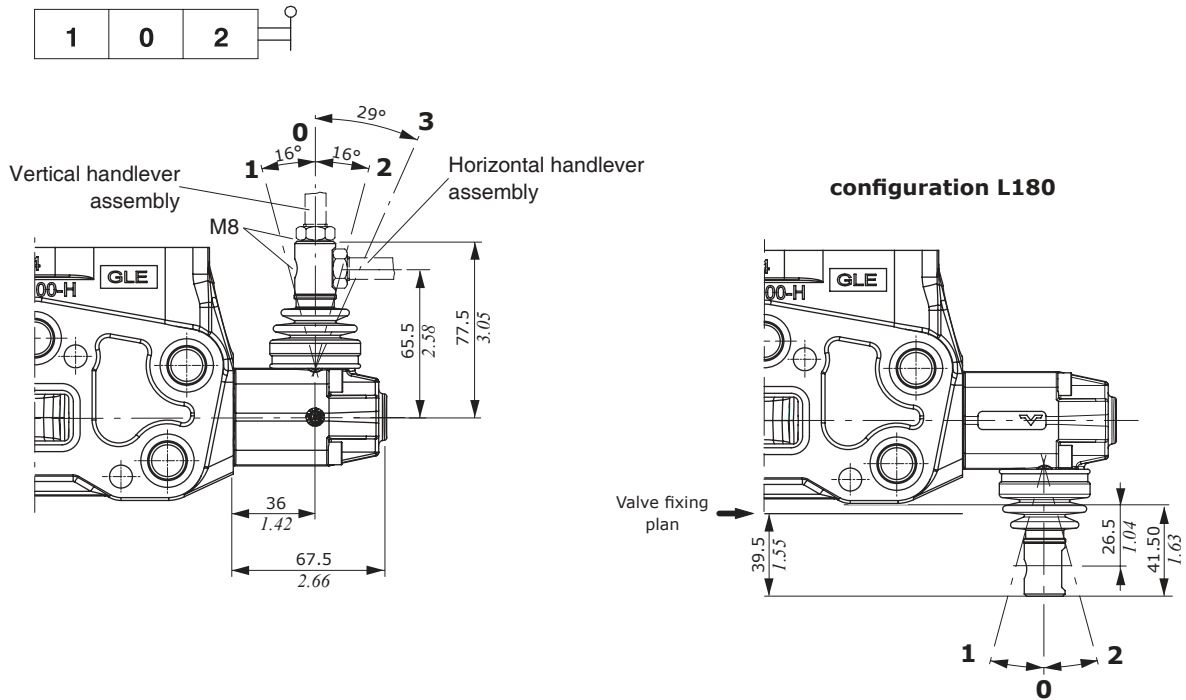

LF1 Type

With spool stroke adjustment in position 12 (P→A). It can be roated 180° (configuration **LF1180**).

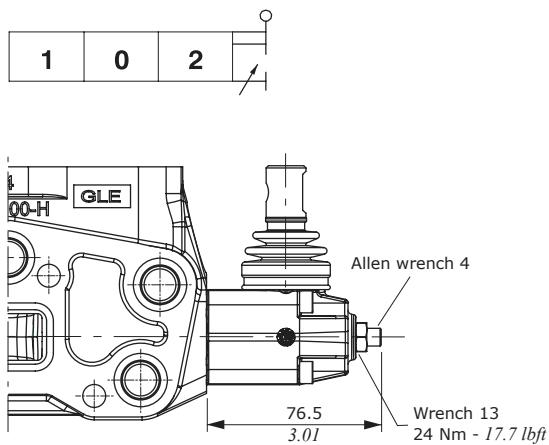

LB Type

Steel construction, with pivot placed down. Assembling with 5B and 5BY type spool is not possible.

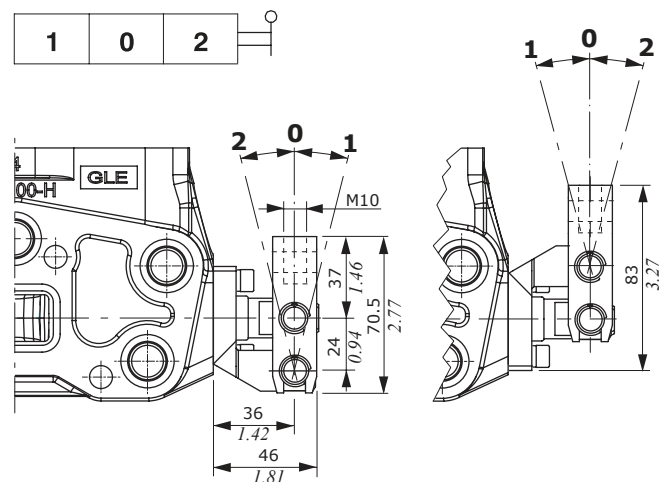

configuration **LB1**

configuration **LB3**

LCB and LCE mechanical joysticks for two sections control

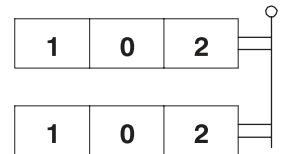
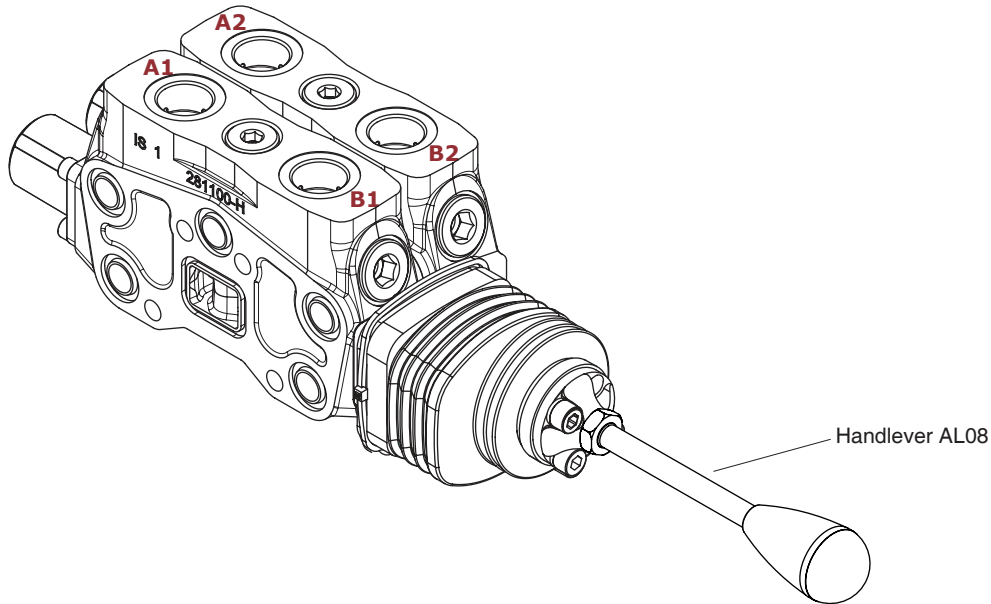

NOTE – The handlever must be ordered separately (see page 27).

Dimensions and movement scheme for left inlet directional valve

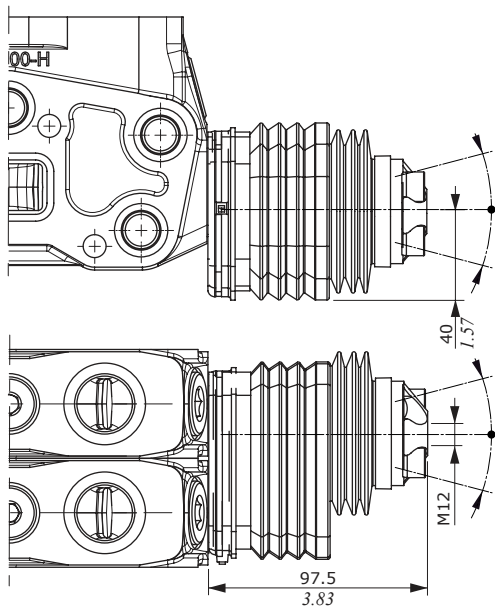

Execution LCB1
pivot placed down on the left

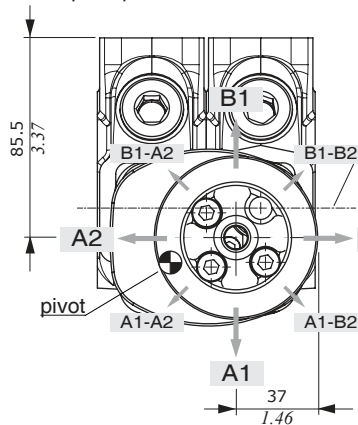

Execution LCB2
pivot placed down on the right

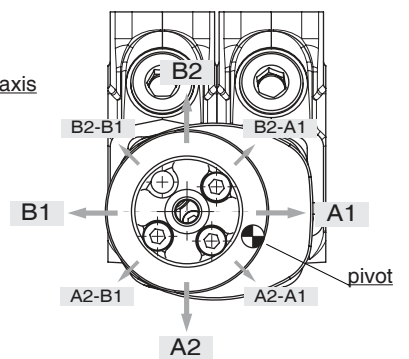

Execution LCB3
pivot placed above to the left

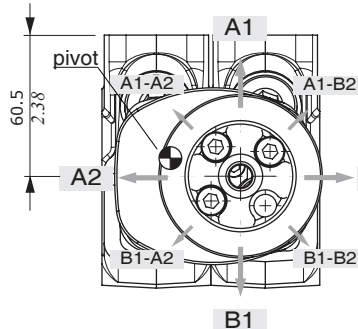

Execution LCB4
pivot placed above to the right

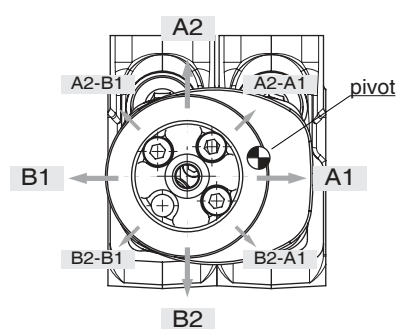

Max. working angles	Horizontal axis	Vertical axis
Single action operation	18°30'	15°30'
Single action operation with floating	not available	not available
Two section operation	18°30'	15°30'
Two section operation with floating	not available	not available

NOTE – Don't use with spool type.

"B" side options

SL type

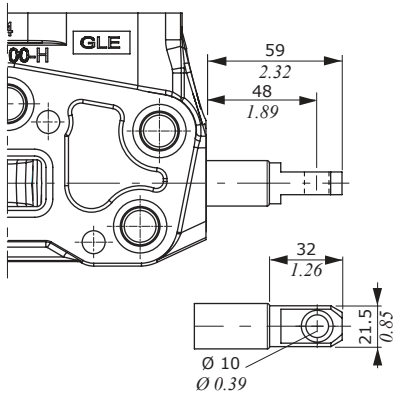

SLP type

Mechanical control with dust-proof plate kit.

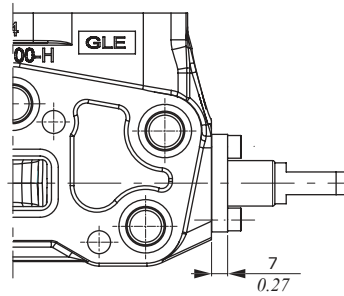
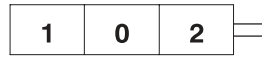

TQ cable remote control kit

Waterproof cap prearranged for remote control with flexible cable.

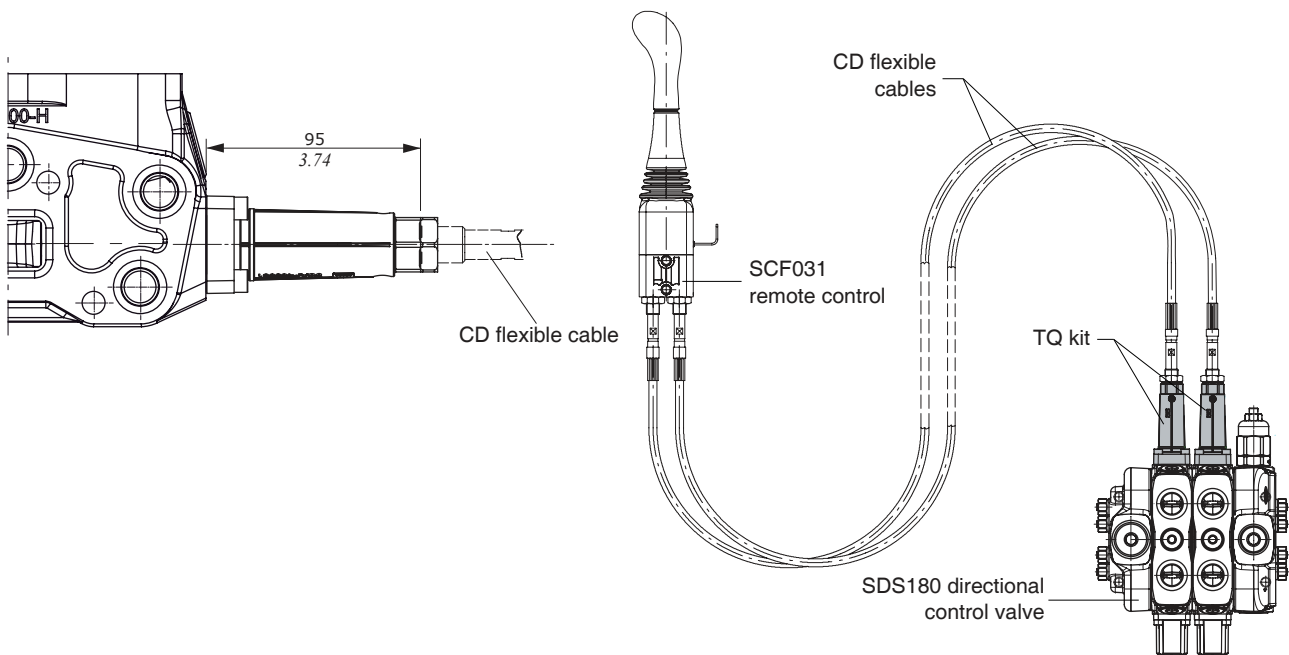
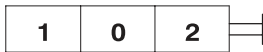

NOTE – For more information about remote cable control, require appropriate documentation.

Proportional hydraulic controls

8IM type

It can be used with special spools and body kit without seals and ring on spool (standard body).

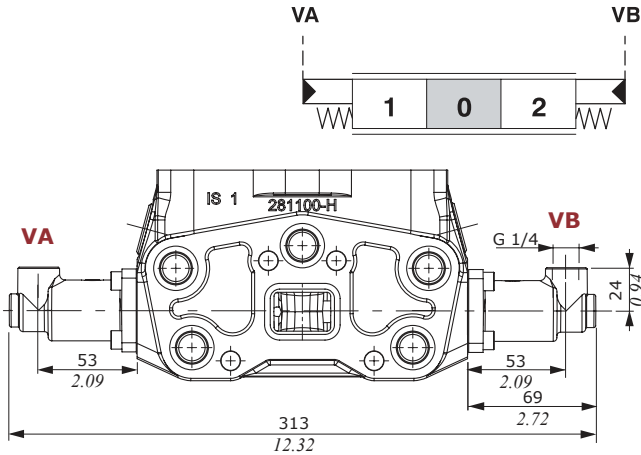

8IMF3 type

Configuration with screws for spool stroke adjustment.

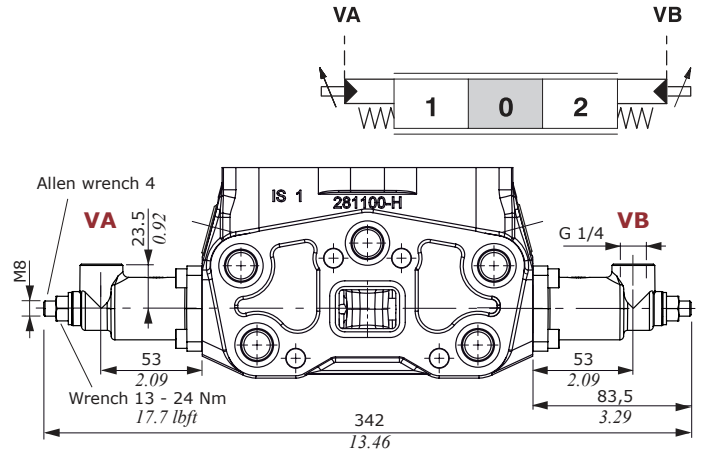

8IMOH type

Steel control kit.

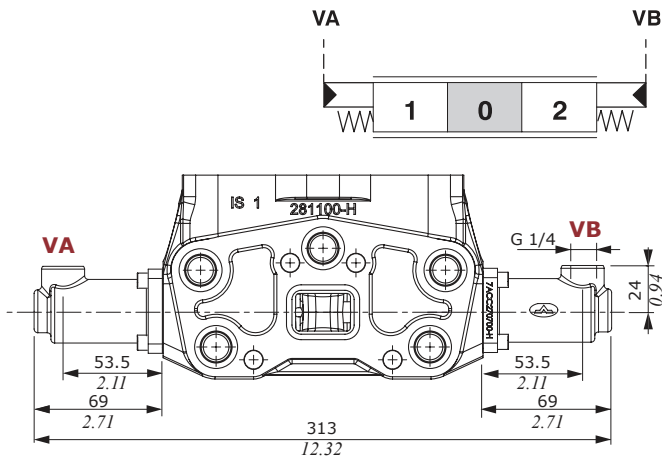

Pressure - stroke diagram
(for controls represented)

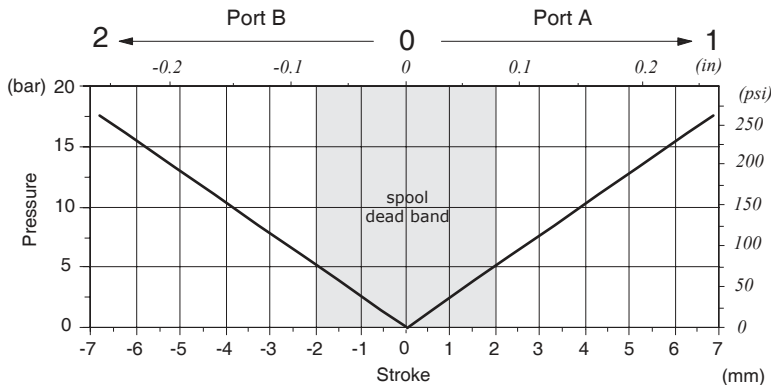

Pressure control curve on
port VA and VB: type 033

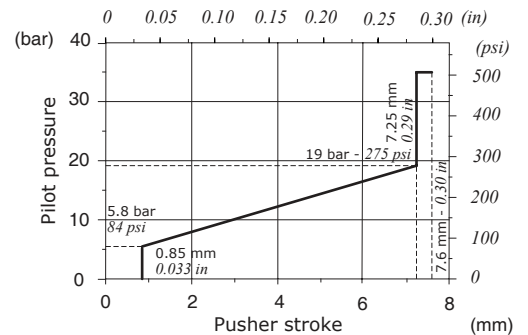

Features

Pilot pressure : max. 100 bar
1450 psi

Note: these drawings are not to scale with the others included in the catalog

Complete controls

Proportional hydraulic control

8IMSPSL4P proportional hydraulic kit

With spool position sensor.

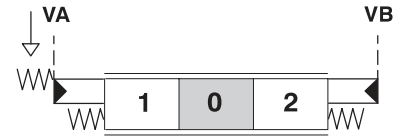
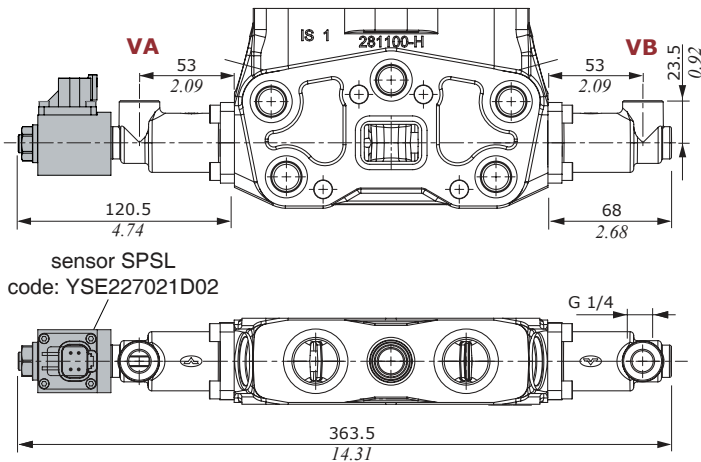

Features

- Pilot pressure : max. 100 bar / 1450 psi
- Connector : Deutsch DT04-4P
- Mating connector cod. 5CON140072 not included

Sensor SPSL

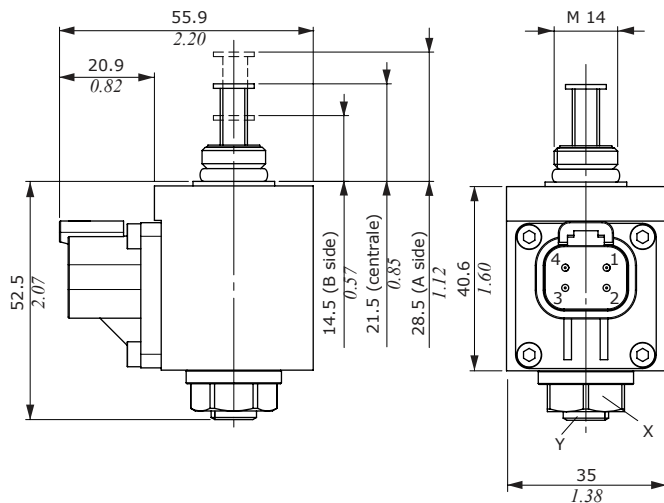

Pin	Signal
1	VCC
2	N.C.
3	GND
4	Out A

	Wrench (mm)	Tightening (Nm)
X	17	9,8
Y	4	9,8

Spool position sensor features

Stroke mechanical	-10/+10 mm • -0.393/+0.393 in
Stroke electrical	-7/+7 mm • -0.275/+0.275 in
Signal range	± 0.2 V
Spool in neutral	2.5 ± 0.2 V
Working temperature	-40/+115 °C • -40/+239 °F
Voltage supply range	5±2% V
Current absorption	<10 mA
Max. current	1 mA
Minimum load resistance	10 KΩ
Working pressure max.	50 bar • 725 psi
Protection index	IP 67 - IP 89K
Vibrations, Shock, Bumps	IEC 68-2-6,27,29
EMC	ISO 13766 - ISO 14982

Output Voltage-spool stroke diagram

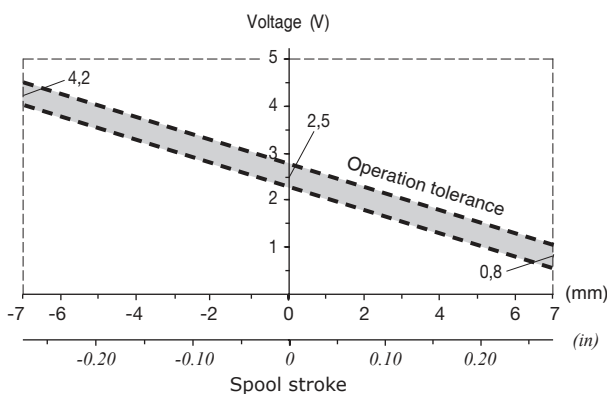

Note: these drawings are not to scale with the others included in the catalog

Proportional hydraulic control

8IMD proportional hydraulic kit

For descent control valve on A. **Need working section kit PHD/IM cod. 5EL1183020A and spool 1IMDA (descent control and load check valve without power supply on port "A") cod. 3CU2510490.**

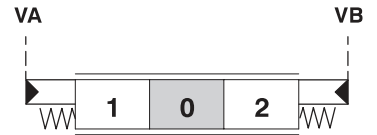
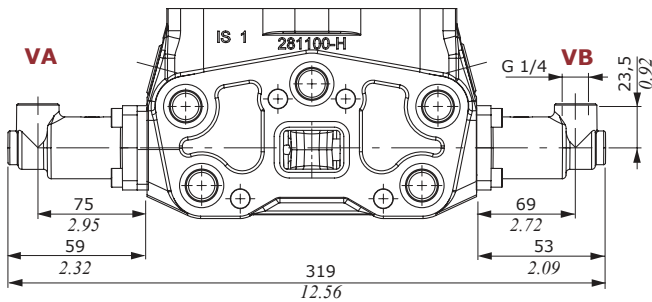

Features

Pilot pressure : max. 100 bar / 1450 psi

Pressure - stroke diagram

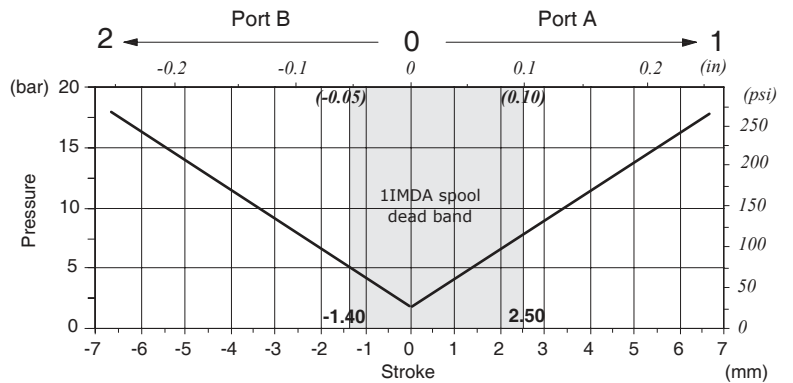
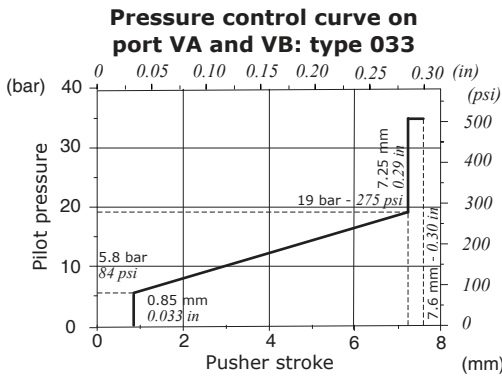

13IMP proportional hydraulic kit

For floating circuit. **Need working section 5IMP cod. 5EL1183205A and spool 5IMP cod. 3CU2542430.**

Note: for dimensions see kit 8IMD

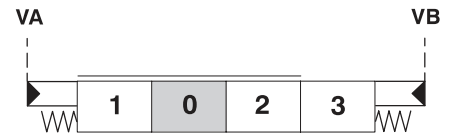
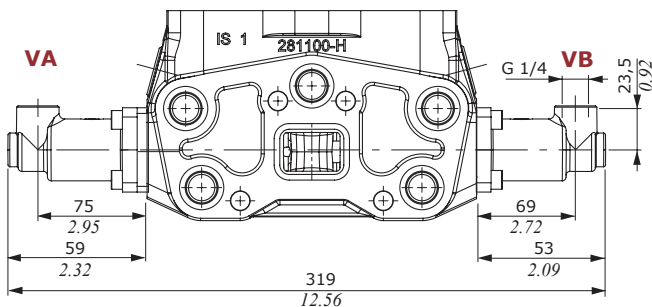

Features

Pilot pressure : max. 100 bar / 1450 psi

Pressure - stroke diagram

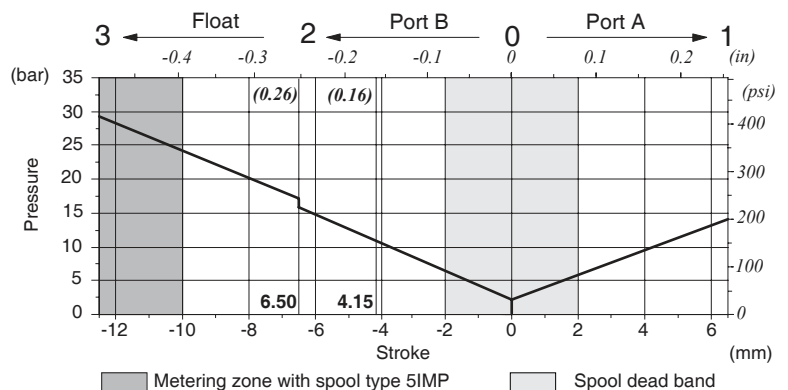
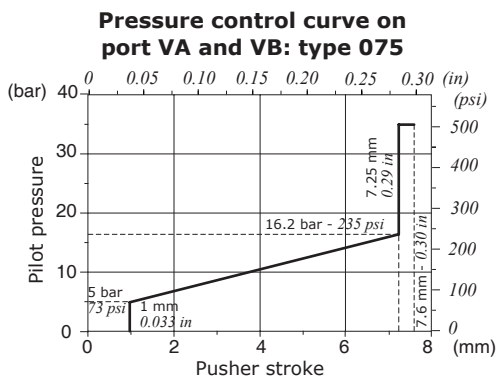

Note: these drawings are not to scale with the others included in the catalog

Port valves

Antishock valves

P 1 (G 3 - 100)

Valve setting in bar

Spring type

Configuration

- 1 mounted on port A
- 2 mounted on port B
- 3 mounted on port A and B

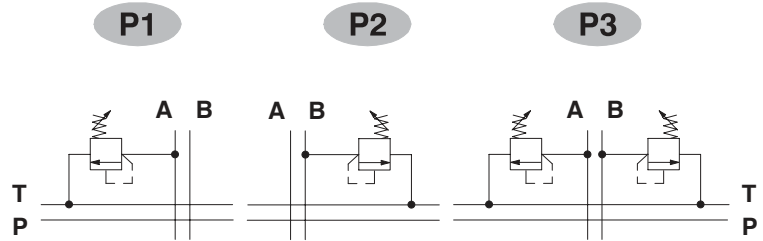

Configuration type G:
with screw

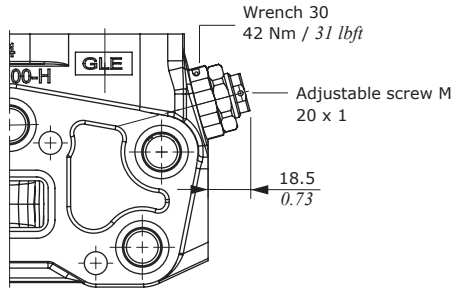

Configuration type H:
valve set and locked

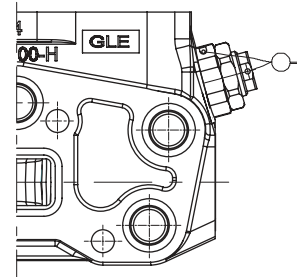

G2 setting range
(green band)

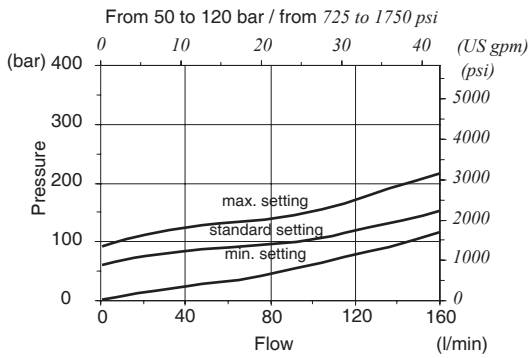

G3 setting range
(blue band)

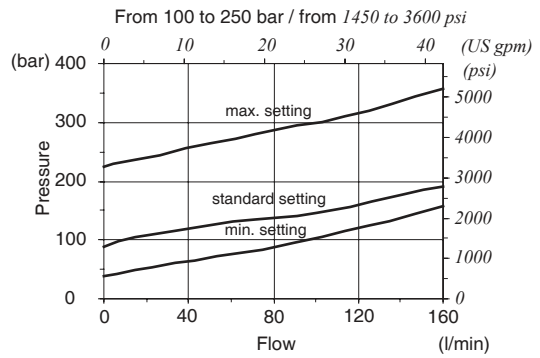

G4 setting range
(red band)

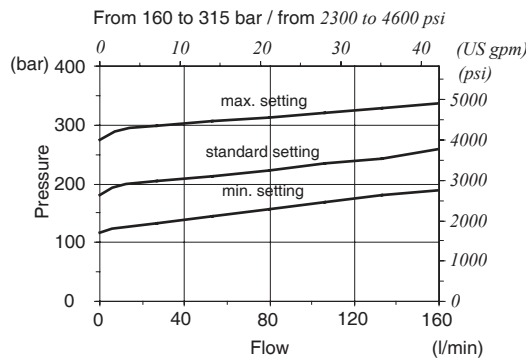

Antishock and anticavitation valves

U 1 (G 3 - 100)

Valve setting in bar
Spring type
Configuration

- 1 mounted on port A
- 2 mounted on port B
- 3 mounted on port A and B

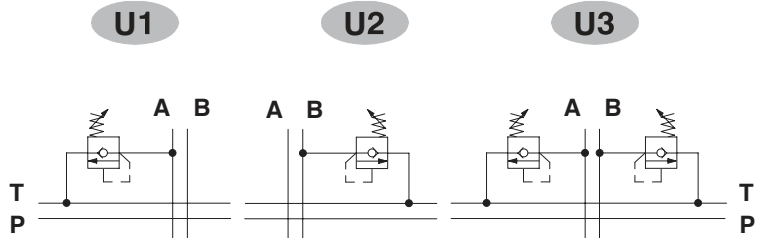

Configuration type G:
with screw

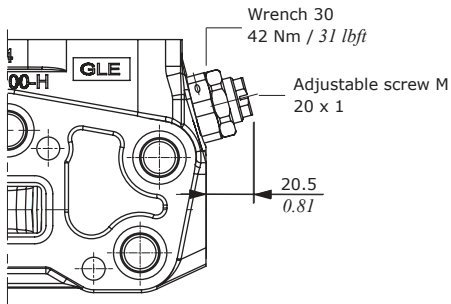

Configuration type H:
valve set and locked

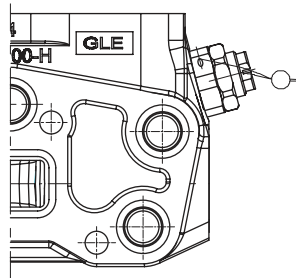

Configuration type Z:
with tamper proof cap

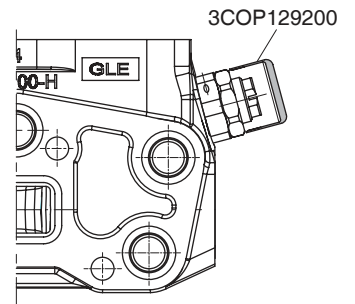

G2 setting range
(green band)

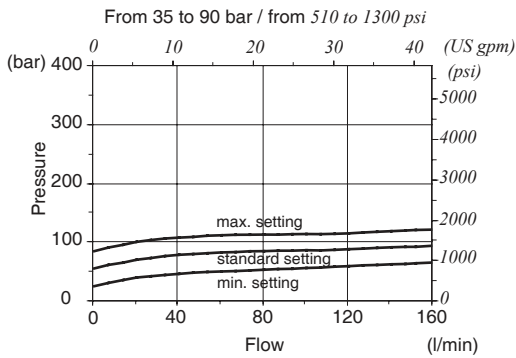

G3 setting range
(blue band)

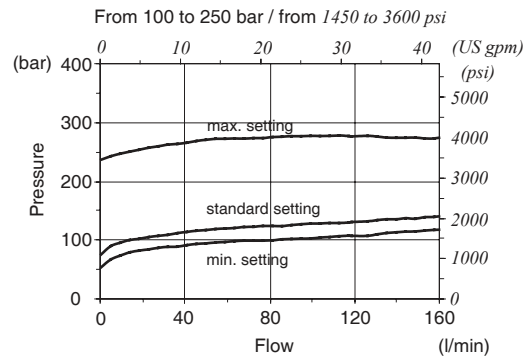

G4 setting range
(red band)

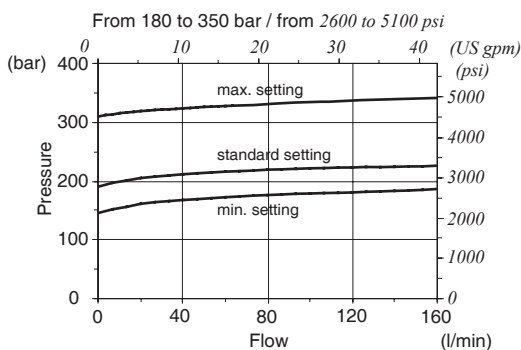

Pressure drop P ⇒ T

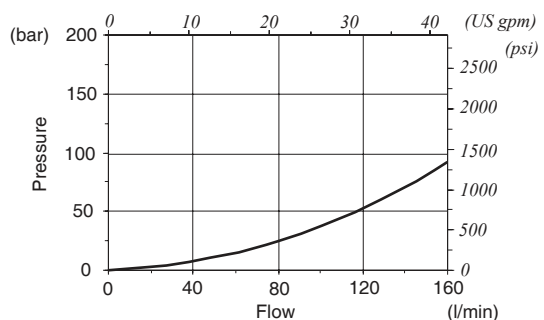

Port valves

Pilot operated anti-shock and anticavitation valves

UXW 1 (G - 160)

Pressure setting in bar

Configuration

- 1 mounted on port A
- 2 mounted on port B
- 3 mounted on port A and B

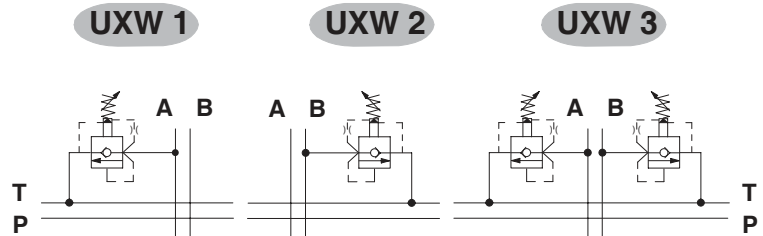

Configuration type G:
with screw

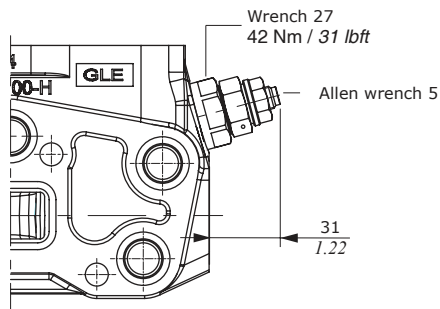

Configuration type H:
valve set and locked

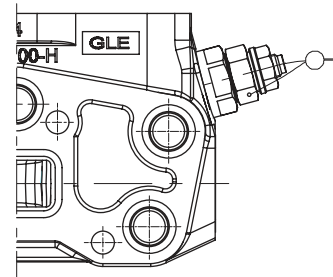

Range setting

From 63 to 315 bar / from 900 to 4600 psi

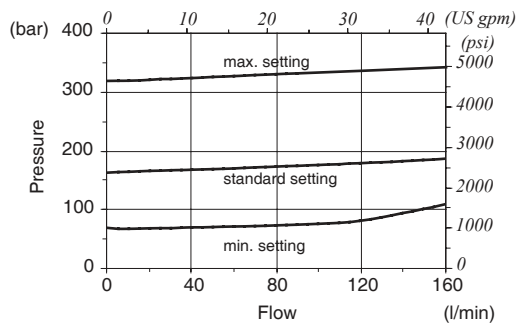

Pressure drop

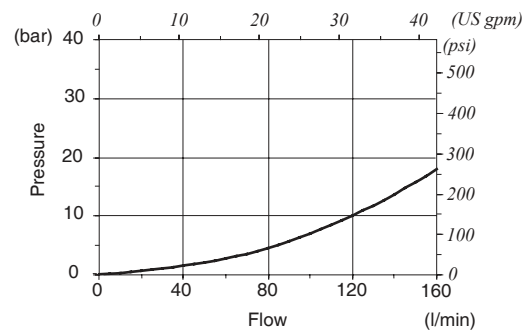

Pilot hydraulic unloader valve

PX 1

- 1 mounted on port A
- 2 mounted on port B
- 3 mounted on port A and B

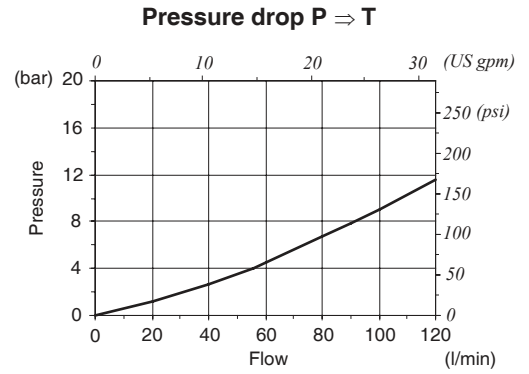
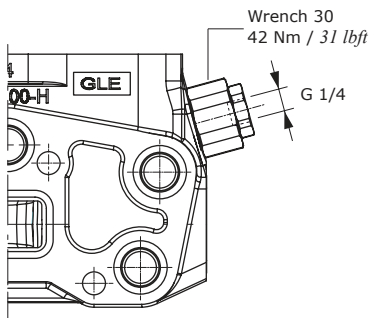
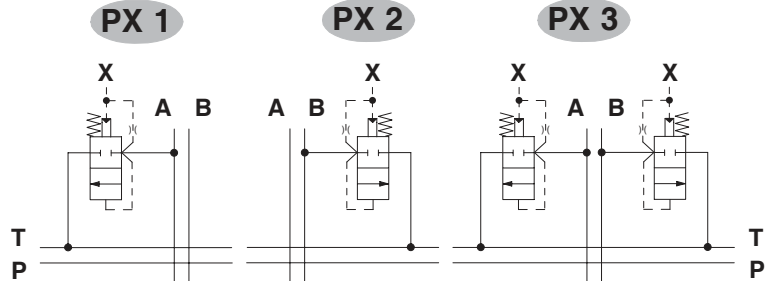

Port valves

Anticavitation valves

C 1

- 1 mounted on port A
- 2 mounted on port B
- 3 mounted on port A and B

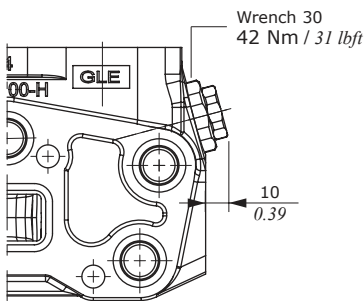
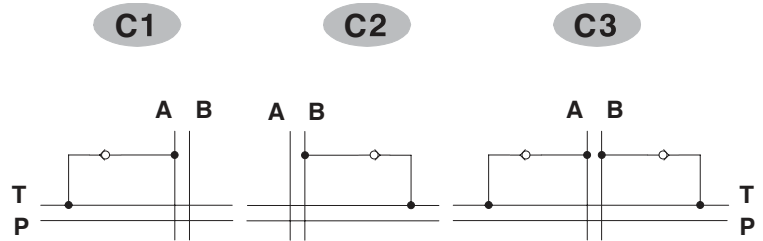

Pressure drop

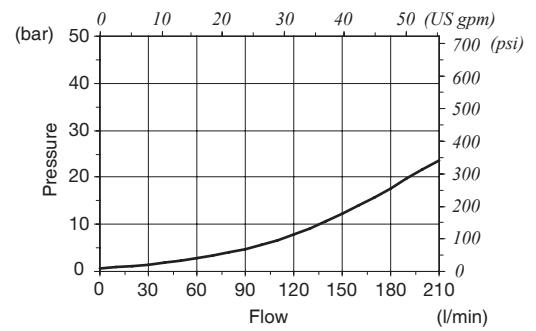

Valve blanking plugs

P 3 T

- 1 mounted on port A
- 2 mounted on port B
- 3 mounted on port A and B

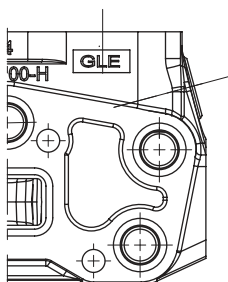
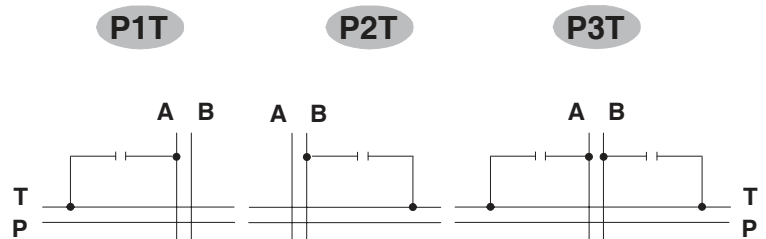

CS1 mid return manifold

Mid return manifolds for directional valve with left and right inlet both; they allow 2 independent circuits with common outlet.

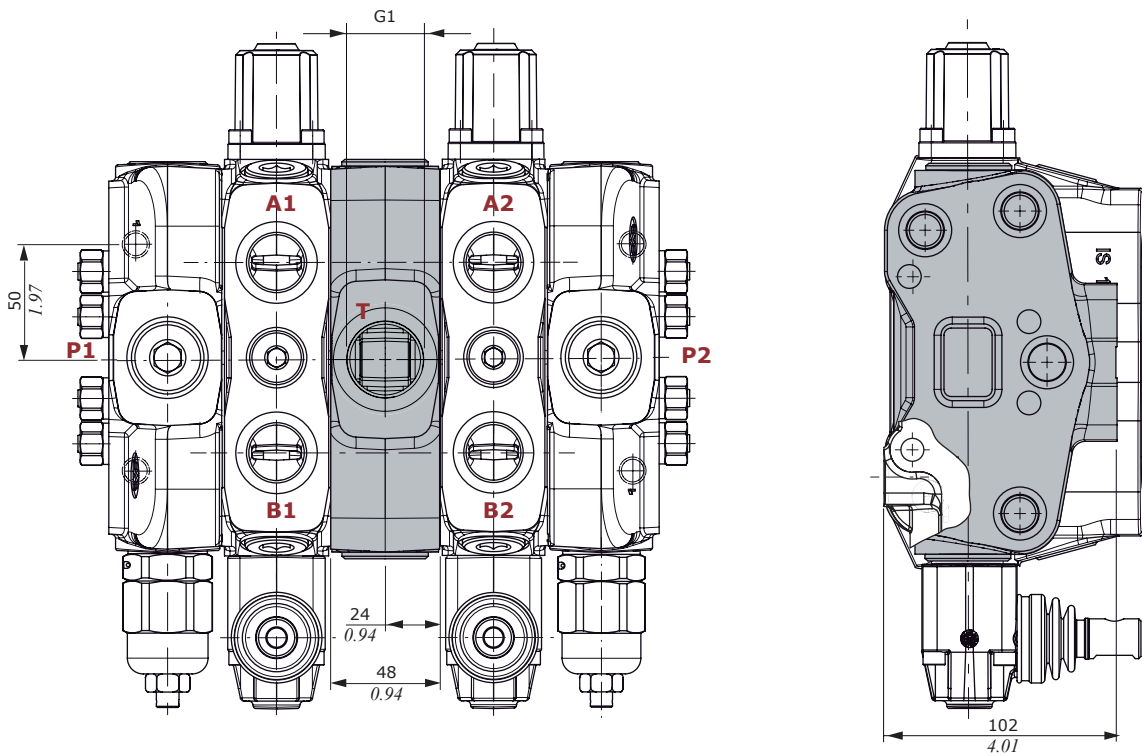

Hydraulic circuit

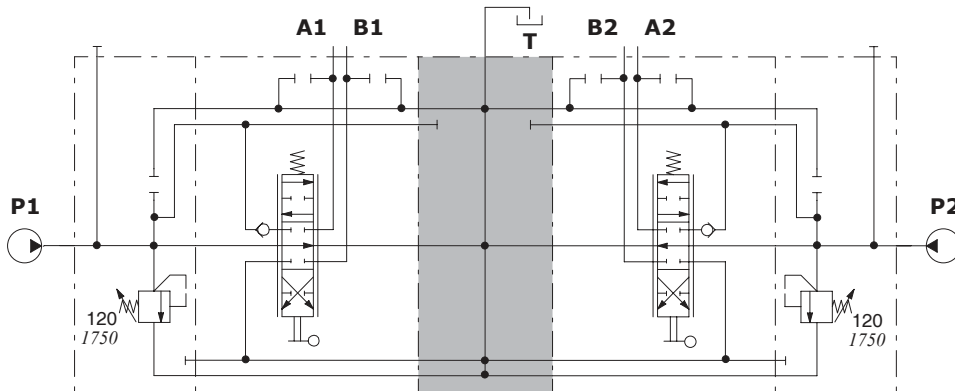

Description example:
 SDS180/2/AC(YG3-120)/18L.UT3/CS1/ 18L.UT3/BC(YG3-120)

CS3 mid return manifold

Mid return manifolds for directional valves SDS180 with left inlet section and SDS150 with right inlet section; they allow 2 independent circuits with common outlet.

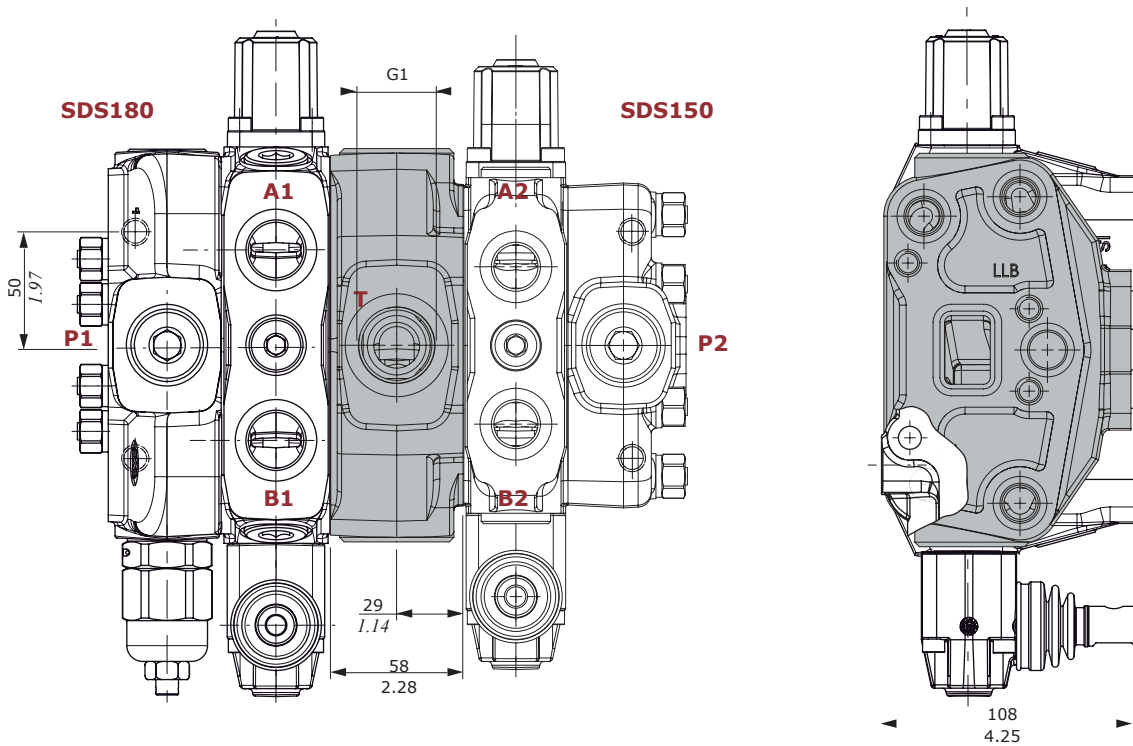

Hydraulic circuit

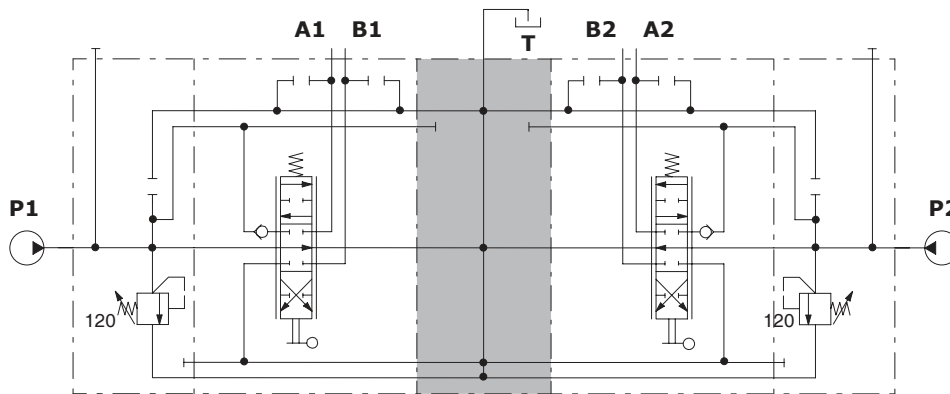

Description example:

SDS180/1/AC(YG3-120)/18L.UT3/CS3/18L.UT3/BC(YG3-120)/SDS150/1

EI configuration

The operation of up stream section exclude the EI downstream section.

The pressure of the downstream sections should be adjusted at least 20 bar below the relief valve setting.

Execution EI2, without plug, is prearranged for a second inlet.

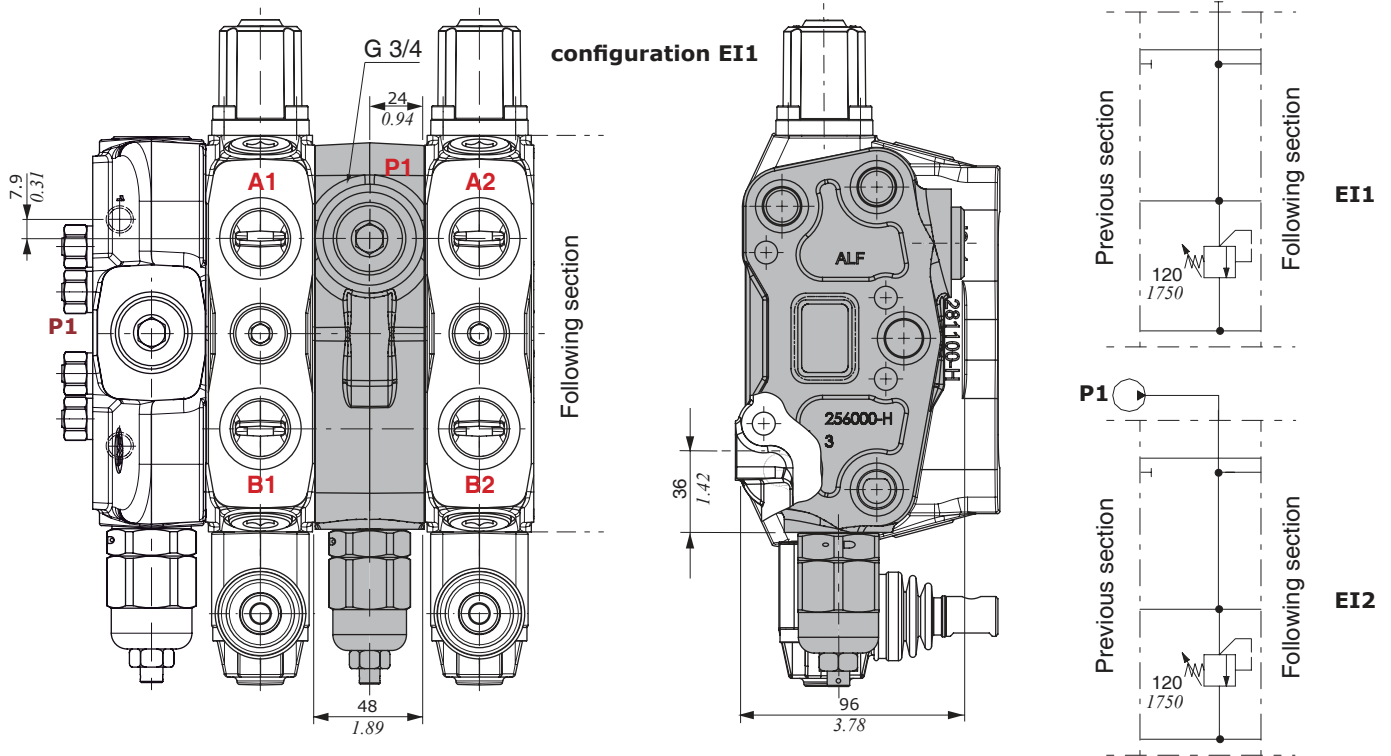

EIM configuration

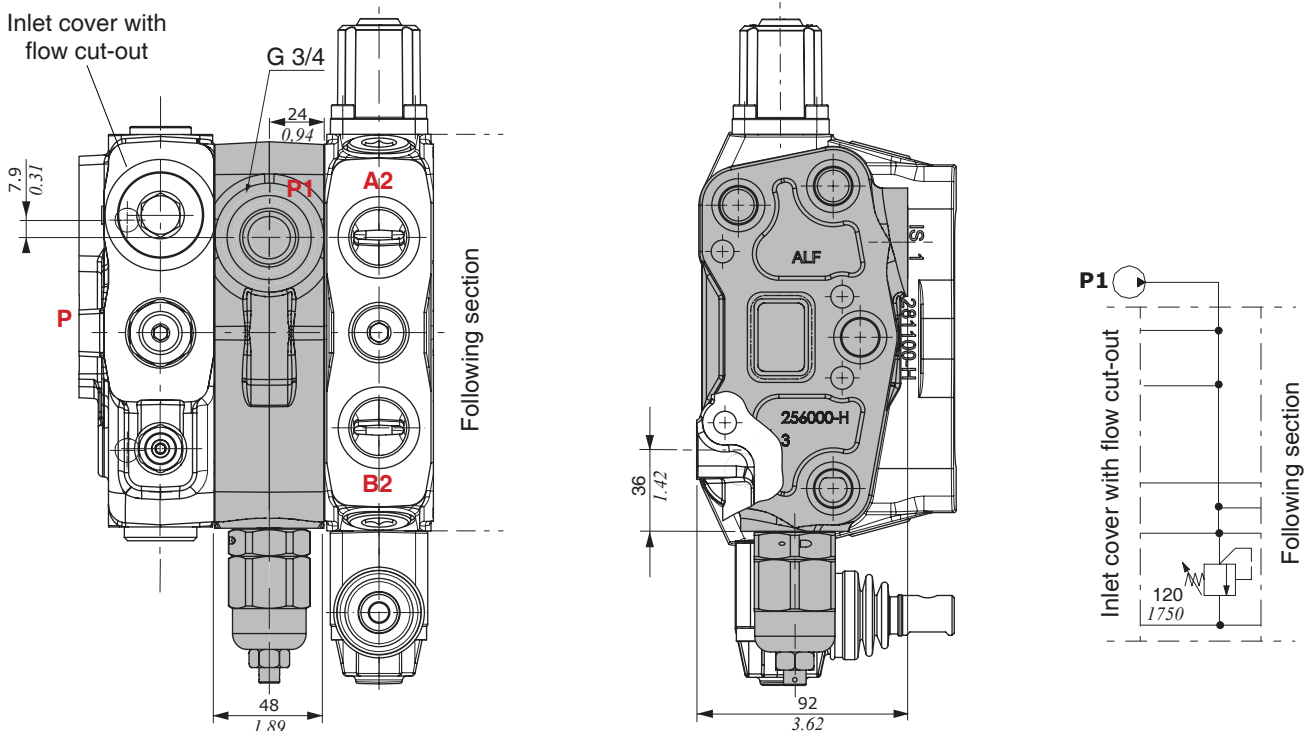

NOTE – EIM intermediate section must be always assembled with inlet cover with flow cut-out.

Parts ordering codes

FS SDS180 / RC

Available configurations

- RC:** side outlet
- RD:** upper outlet
- RE:** upper outlet with side carry-over
- RK:** upper outlet and closed centre
- RV:** upper outlet with backpressure valve (see page 40)

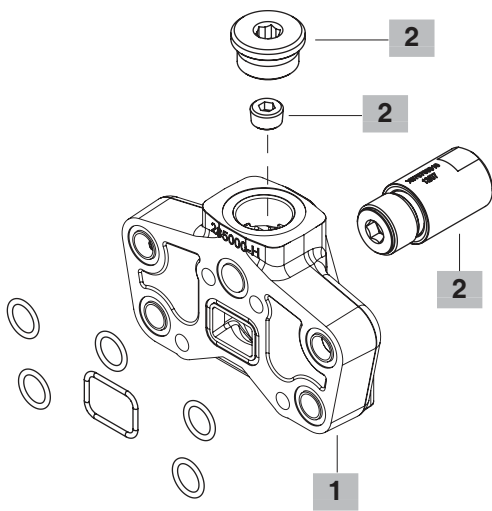

1 Complete outlet cover

TYPE	CODE	DESCRIPTION
RC	618301003	Side outlet
RD	618301002	Upper outlet
RE	618301001	Upper outlet with side carry-over sleeve
RK	618301004	Upper outlet with closed center
RV	618301009	With backpressure valve

2 Circuit options

TYPE	CODE	QTY	DESCRIPTION
-	4TAP318010	1	M18x1.5 tapered plug for carry-over (RE), carry-over with backpressure valve (RV) and closed centre (RK) options
VRE(6)	X076710006	1	Backpressure valve (6 bar / 87 psi) for RV configuration
VRE	X076700010	1	Backpressure valve (10 bar / 145 psi) for RV configuration
-	3XTAP740210	1	Plug G 1

Dimensional data and hydraulic circuit

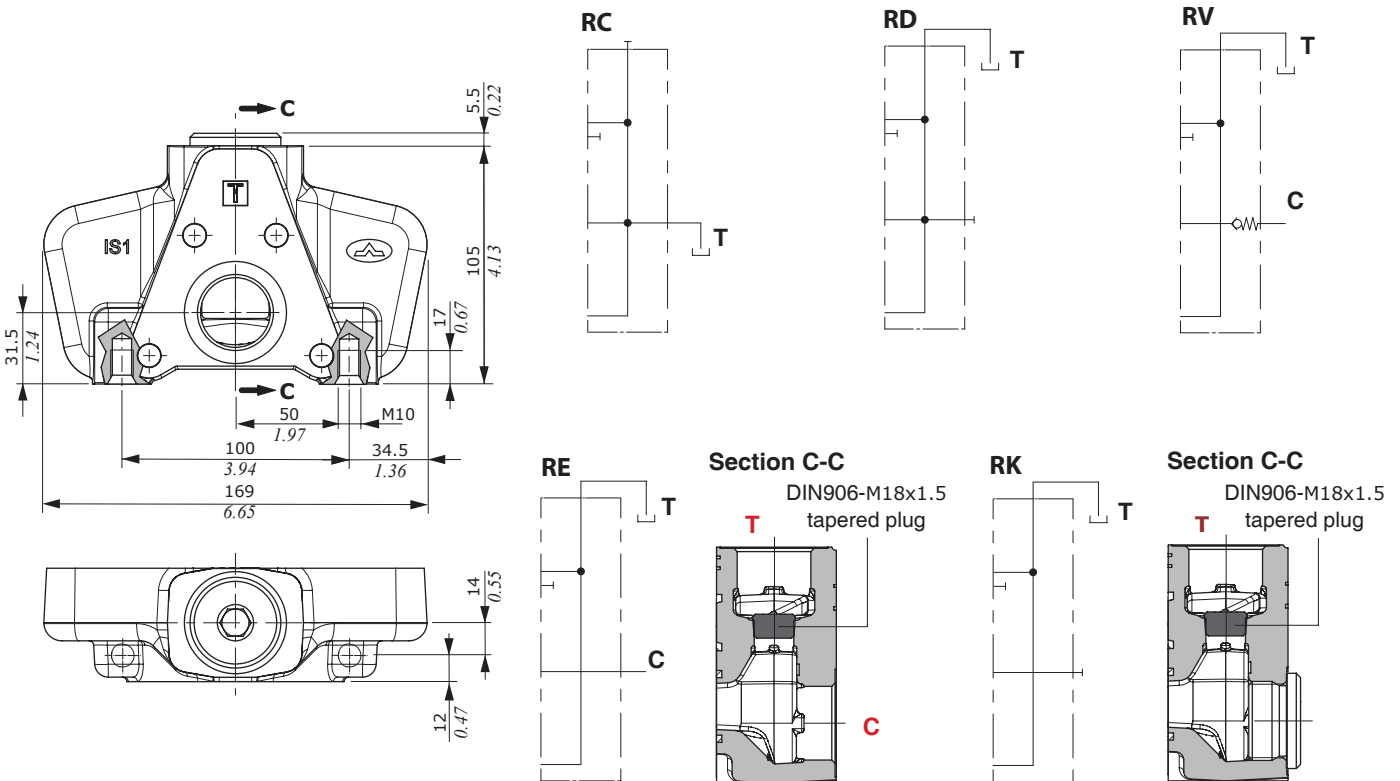

Working conditions

This catalogue shows technical specifications and diagrams measured with mineral oil of 46mm²/s - 46 cSt viscosity at 40°C - 104°F temperature.

Nominal flow rating	on inlet P	180 l/min	47 US gpm
	on ports A and B	160 l/min	42 US gpm
Max pressure (¹)		315 bar	4600 psi
Standard stand by		14 bar	203 psi
Internal leakage (standard) A(B)⇒T	Δp = 100 bar - 1450 psi	5 cm ³ /min	0.30 in ³ /min
Fluid		Mineral based oil	
Fluid temperature	with NBR (BUNA-N) seals	from -20°C to 80°C	from -4°F to 176°F
	with FPM (VITON) seals	from -20°C to 100°C	from -4°F to 212°F
Viscosity	operating range	from 15 to 75 mm ² /s	from 15 to 75 cSt
	min.	12 mm ² s	12 cSt
	max.	400 mm ² s	400 cSt
Max. contamination level		-/19/16 - ISO 4406	NAS 1638 - class 10
Ambient temperature for working conditions		from -40°C to 60°C	from -40°F to 140°F

NOTE - (¹) Intermittent pressure at max. 250,000 cycles with specific internal testing.

Standard threads

REFERENCE STANDARD				
		BSP	UN-UNF	NPTF
THREAD ACCORDING TO		ISO 228/1	ISO 263	NSI B1.20.3
		BS 2779	ANSI B1.1 unified	
CAVITY DIMENSION ACCORDING TO	ISO	1179-1	11926-1	
	SAE		J1926-1	J476a
	DIN	3852-2 shape X or Y		

PORTS THREADING			
MAIN		BSP	UN-UNF
Inlet P - Outlet T		G 1	1 5/16-12 (SAE 16)
Ports A and B		G 3/4	1 1/16-12 (SAE 12)
Load sensing LS		G 1/4	9/16-18 (SAE 6)
PILOT			
Hydraulic		G 1/4	9/16-18 (SAE 6)

Dimensional data

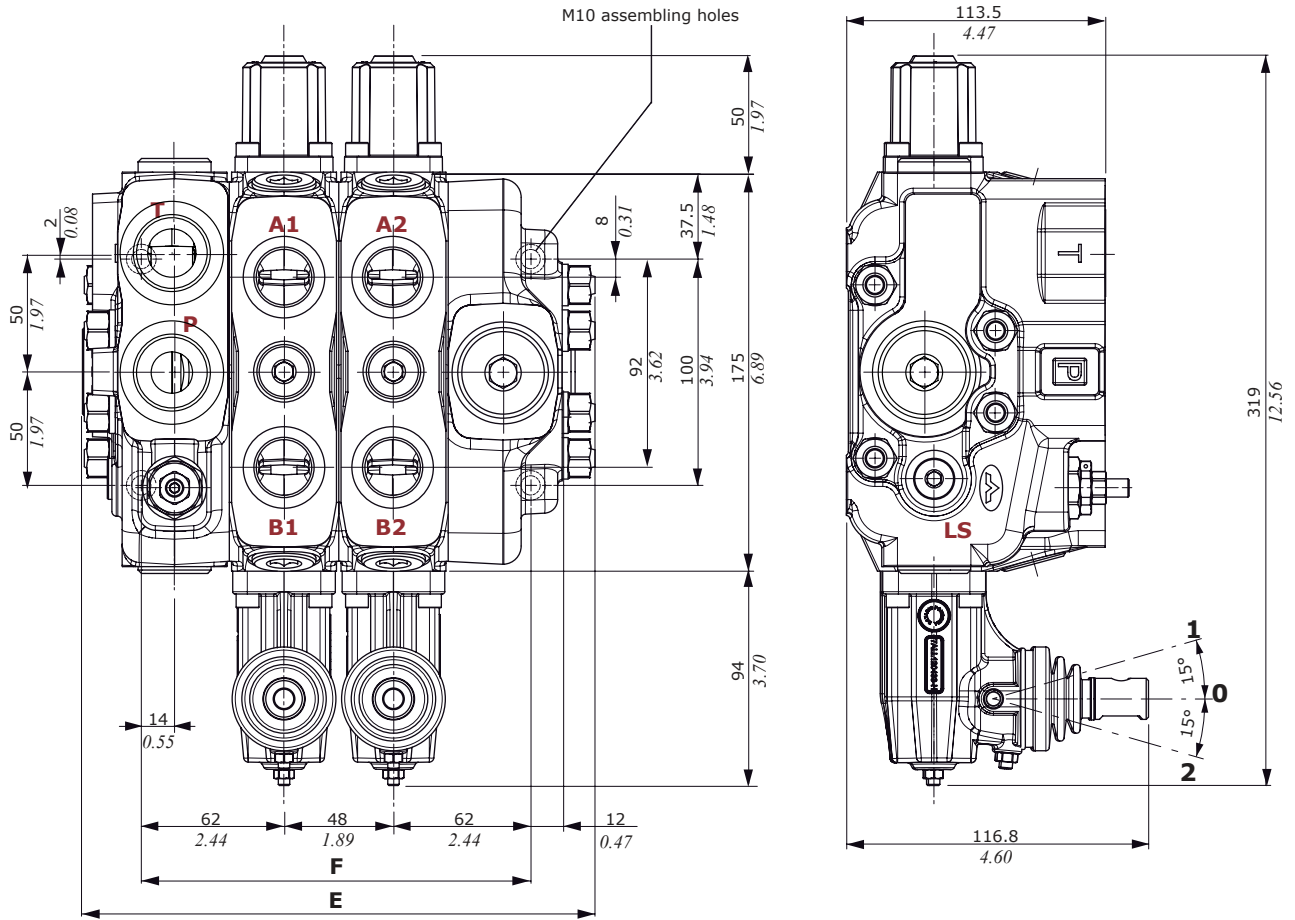

NOTE: Drawings and dimensions are referred to BSP thread configuration.

TYPE	E		F		Weight	
	mm	in	mm	in	Kg	lb
DLS180/1	177,8	7	124	4.88	13.8	30.42
DLS180/2	225,8	8.89	172	6.77	19.2	42.33
DLS180/3	273,8	10.78	220	8.66	24.6	54.23
DLS180/4	321,8	12.67	268	10.55	30	66.14
DLS180/5	369,8	14.56	316	12.44	35.4	78.04
DLS180/6	417,8	16.45	364	14.33	40.8	89.95

TYPE	E		F		Weight	
	mm	in	mm	in	Kg	lb
DLS180/7	465,8	18.34	412	16.22	46.2	101.85
DLS180/8	513,8	20.23	460	18.11	51.6	113.76
DLS180/9	561,8	22.12	508	20.00	57	125.66
DLS180/10	609,8	24	556	21.89	62.4	137.57
DLS180/11	657,8	25.90	604	23.78	67.8	149.47
DLS180/12	705,8	27.76	652	25.67	73.2	161.38

Performance data

P ⇒ T pressure drop inlet compensator (margin pressure)

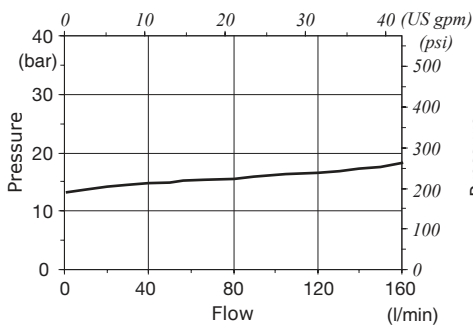

P ⇒ A(B) pressure drop (standard spool @ max. stroke)

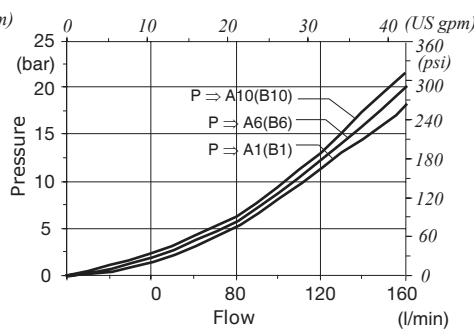

A(B) ⇒ T pressure drop

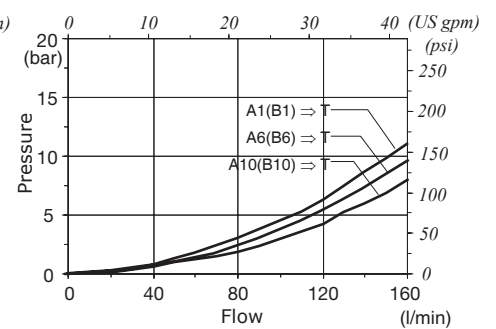

Hydraulic circuit

For open center circuit (fixed displacement pump)

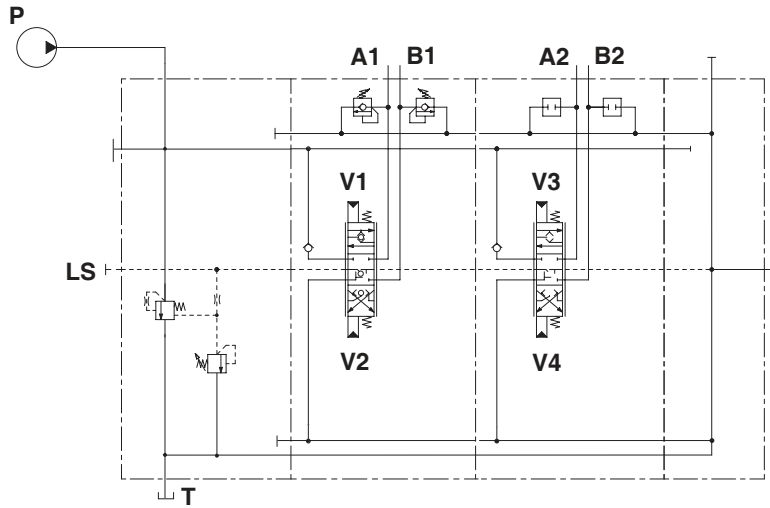

Description example:
DLS180/2/AMD(G4-210)/6ZM8IMF3.U3(G3-170)/6ZM8IMF3/RF

For closed center circuit (variable displacement pump with Load-Sensing compensator)

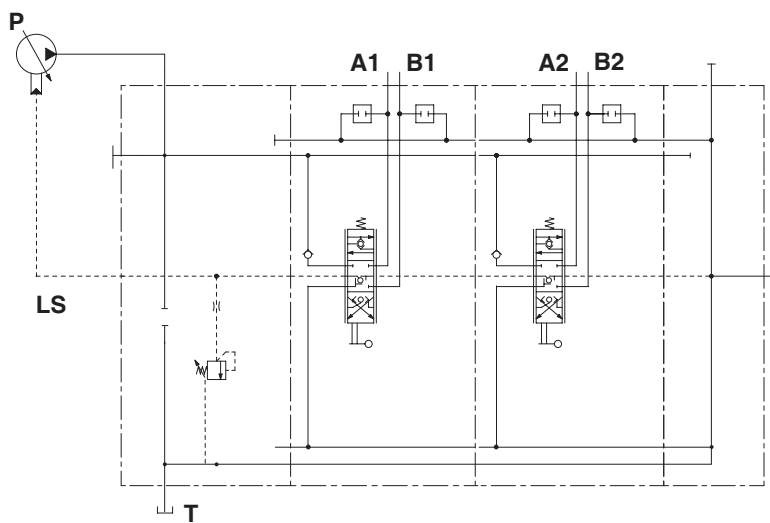

Description example:
DLS180/2/AND(G3-120)/6ZLF3/6ZLF3/RF

Complete sections ordering codes

DLS180 / 2 / AMD(G3-120) / 6ZLF3 / 6ZLF3 / RF - STAF

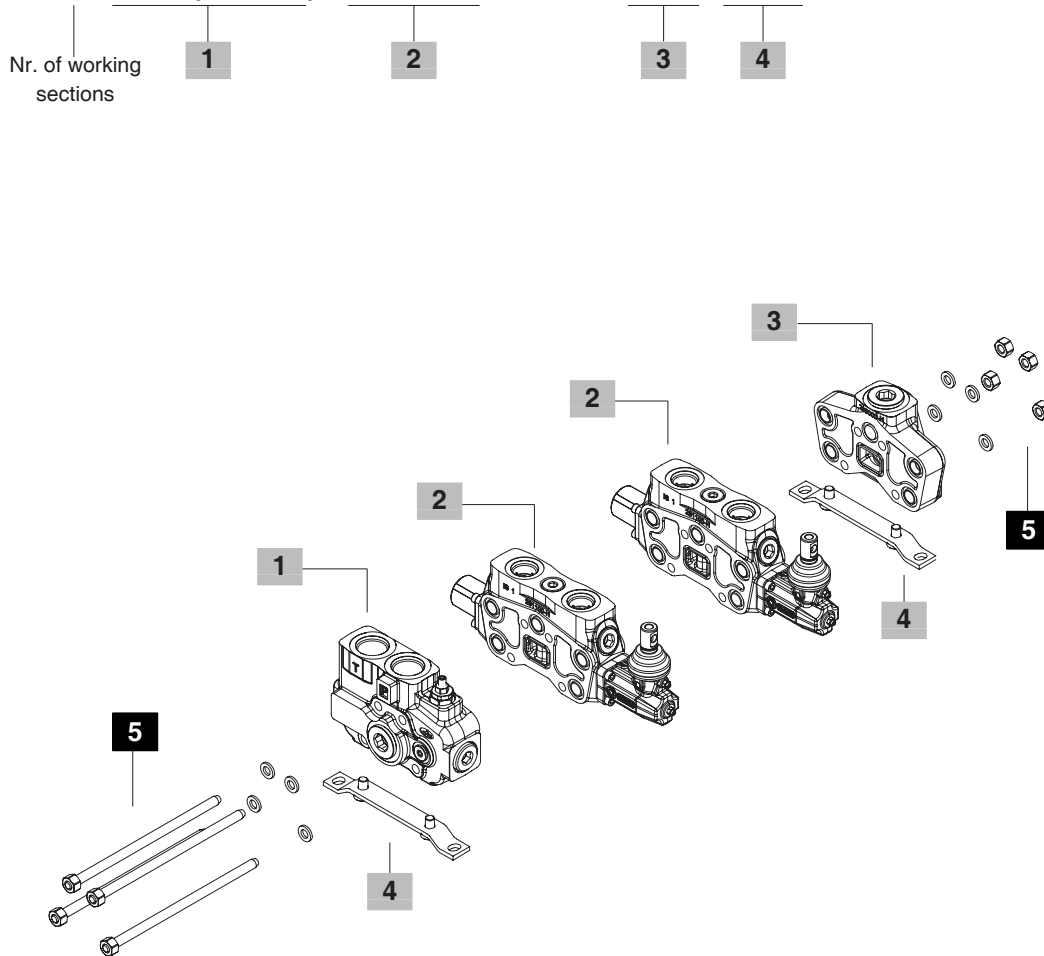

1 Inlet section * page 60

TYPE	CODE	DESCRIPTION
AMD(G3-120)	61F331000	For open centre circuit, with L.S. pressure relief valve
AMDT(G3-120)	61F311002	As previous with upper outlet closed
AND(G3-120)	61F332000	For closed centre circuit, with L.S. pressure relief valve
ANDT(G3-120)	61F312002	As previous with upper outlet closed
APD(SV)	61F333000	Without compensator and L.S. pressure relief valve
APDT(SV)	61F313002	As previous with upper outlet closed

2 Working section * page 62

TYPE	CODE	DESCRIPTION
6Z8LF3	61F131601	Parallel circuit, lever control
6ZM8IMHF3	61F131602	Parallel circuit, proportional hydraulic control with spool stroke limiter

3 Outlet section * page 68

TYPE	CODE	DESCRIPTION
RF	618301008	With ports plugged
RD	618301014	Upper outlet
RC	618301013	Side outlet

4 Fixing bracket page 73

TYPE	CODE	DESCRIPTION
STAF	5STA125220	Brackets with fixing screws

5 Assembling kit

CODE	DESCRIPTION
5TIR110170	Tie rod kit for 1 working section directional valve
5TIR110218	Tie rod kit for 2 working sections directional valve
5TIR110266	Tie rod kit for 3 working sections directional valve
5TIR110316	Tie rod kit for 4 working sections directional valve
5TIR110368	Tie rod kit for 5 working sections directional valve
5TIR110410	Tie rod kit for 6 working sections directional valve
5TIR110458	Tie rod kit for 7 working sections directional valve
5TIR110506	Tie rod kit for 8 working sections directional valve
5TIR110554	Tie rod kit for 9 working sections directional valve
5TIR110602	Tie rod kit for 10 working sections directional valve
5TIR110650	Tie rod kit for 11 working sections directional valve
5TIR110698	Tie rod kit for 12 working sections directional valve

NOTE (*) – Codes are referred to **BSP** thread.

Parts ordering codes

FE DLS180 / AM D T (G3 - 120)

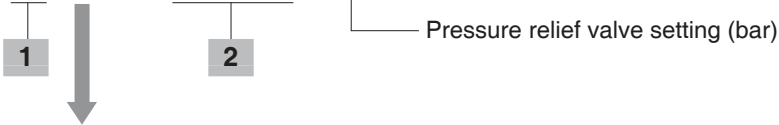

Available configurations

- D: With side inlet port closed
- C: With upper inlet port closed

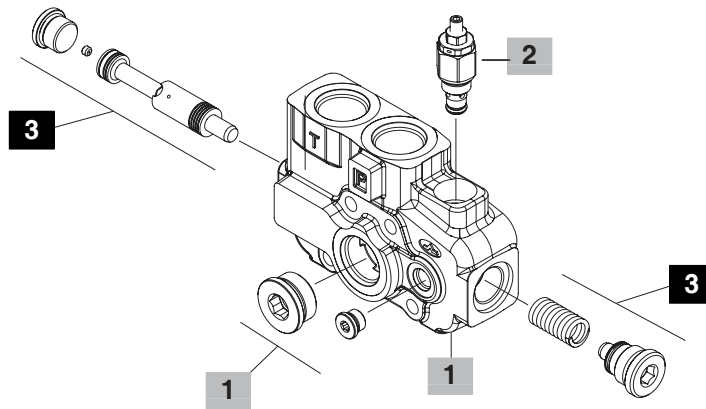

1 Inlet cover body * page 61

TYPE	CODE	DESCRIPTION
AM	5FIA318300	For fixed displacement pump, L.S. compensator (open centre) with main relief valve
AN	5FIA318301	For variable displacement pump, (closed centre) with main relief valve
AP	5FIA318302	For variable displacement pump, (closed centre) without main relief valve

2 Inlet relief options page 21

Standard setting is referred to 10 l/min - 2.6 US gpm flow.

TYPE	CODE	DESCRIPTION
SV	XTAP525320	Relief valve blanking plug

Load Sensing main relief valve

LSW(G2)	5KIT118110	Range 5-50 bar / 72-720 psi standard setting 30 bar / 400 psi
LSW(G3)	5KIT118111	Range 50-200 bar / 720-3200 psi standard setting 150 bar / 2150 psi
LSW(G4)	5KIT118112	Range 180-315 bar / 2600-4550 psi standard setting 250 bar / 3600 psi

3 Compensator kit

CODE	DESCRIPTION
5KIT018300	Compensator kit, for AM section
5KIT018310	Compensator blanking kit, for AN and AP section

NOTE (*) - Codes are referred to **BSP** thread.

Dimensional data and hydraulic circuit

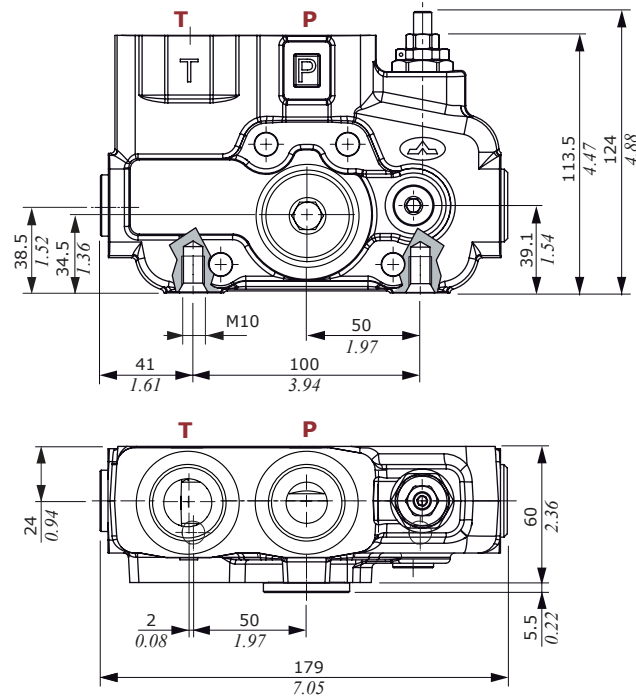

For fixed displacement pump, L.S. compensator (open centre) with main relief valve

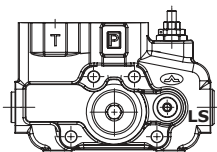
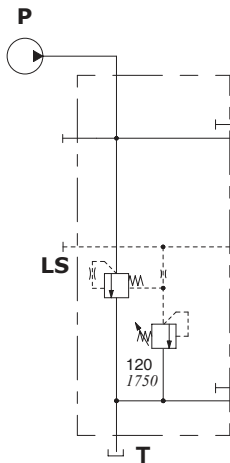

Description example: **AMD(G3-120)**

For variable displacement pump, (closed centre) with main relief valve

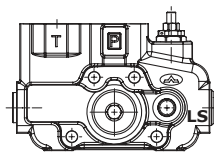
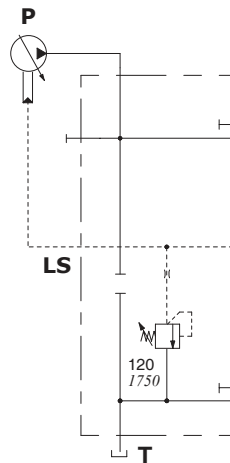

Description example: **AND(G3-120)**

For variable displacement pump, (closed centre) without main relief valve

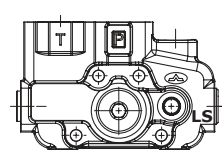
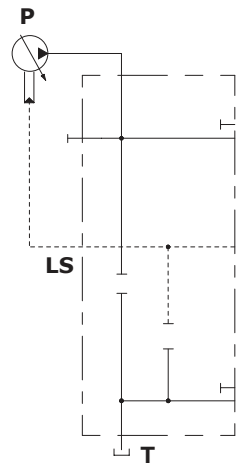

Description example: **APD(SV)**

Parts ordering codes (mechanical control)

EL DLS180 / 6Z 8 LF3 P1 (G3 - 100)

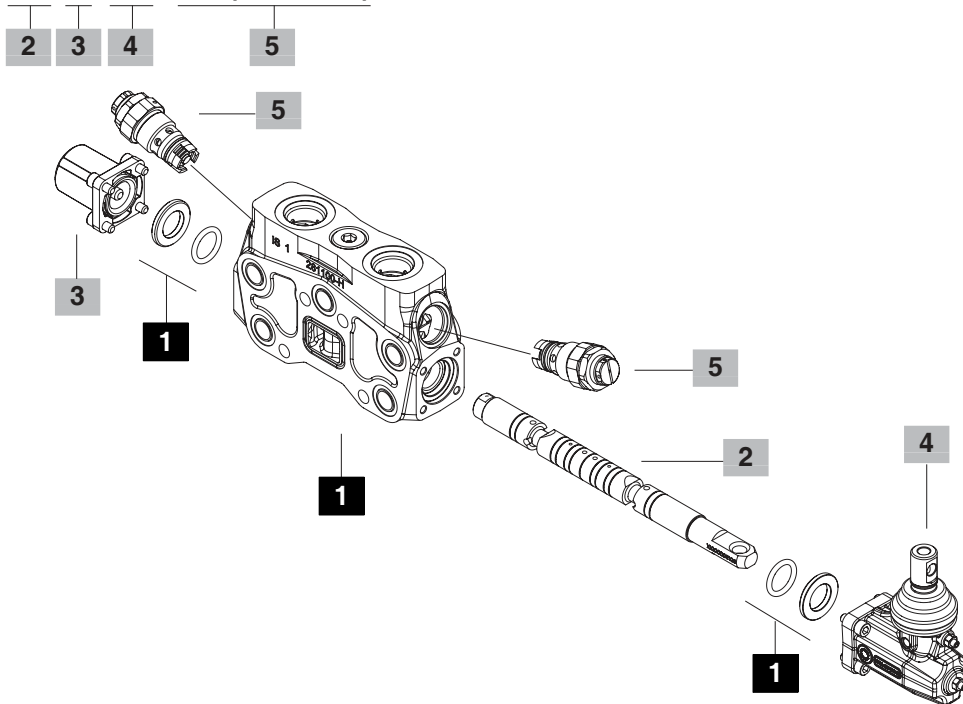

1 Working section kit * page 64

TIPO	CODICE	DESCRIZIONE
P	5EL5183000	Parallel circuit for hydraulic controls

2 Spools page 64

Double acting, 3 positions, with A and B closed in neutral position.

6QM	3CU3610040	For flow 40 l/min - 10.57 Us gpm
6OM	3CU3610080	For flow 80 l/min - 21.13 Us gpm
6VM	3CU3610120	For flow 120 l/min - 31.70 Us gpm
6ZM	3CU3610140	For flow 140 l/min - 36.98 Us gpm

Double acting, 3 positions, with A and B to tank in neutral position.

7V	3CU3625120	For flow 120 l/min - 31.70 Us gpm
7Z	3CU3625140	For flow 140 l/min - 36.98 Us gpm

3 "A" side spool positioners page 65

TYPE	CODE	DESCRIPTION
7FT	5V07210100	With friction and neutral position sensor
8MC	5V08210000	With spring return in neutral position
9BZ	5V09110030	With detent in position 1 and spring return in neutral position
10BZ	5V10110030	With detent in position 2 and spring return in neutral position
11BZ	5V11110030	Detent in positions 1 and 2 and spring return in neutral position
8IZ	5V08110800	Proportional hydraulic control

4 "B" side options page 65

TYPE	CODE	DESCRIPTION
L	5LEV110110-H	Standard lever box
LF3	5LEV110115-H	Lever box with spool stroke limiter
LA	5LEV110125-H	Steel lever kit
LAF3	5LEV110120-H	Steel lever kit with spool stroke limiter
SLP	5COP110000	With dust-proof plate
TQ	5TEL118100-H	Cable connection

5 Port valves page 46

Valves standard setting is referred to 10 l/min - 2.64 USgpm flow.

TYPE	CODE	DESCRIPTION
P3T	XTAP530361	A and B ports valve blanking plugs, omitted from the description
C	3XCAR416100	Anti-cavitation valve
Anti-shock valve		
P(G2)	XCAR216115	Range 50-120 bar / 725-1750 psi standard setting 63 bar / 900 psi
P(G3)	XCAR216116	Range 100-250 bar / 1450-3600 psi standard setting 100 bar / 1450 psi
P(G4)	XCAR216117	Range 160-315 bar / 2300-4600 psi standard setting 200 bar / 2900 psi

Pilot hydraulic unloader valve

PX	XCAR416301	Pilot hydraulic unloader valve
----	------------	--------------------------------

Anti-shock and anti-cavitation valve

U(G2)	X011411099	Range 35-90 bar / 510-1300 psi standard setting 60 bar / 870 psi
U(G3)	X011411100	Range 100-250 bar / 1450-3600 psi standard setting 100 bar / 1800 psi
U(G4)	X011411101	Range 180-350 bar / 2600-5100 psi standard setting 200 bar / 2900 psi

Pilot operated anti-shock and anti-cavitation valve

UXW(G)	X01141B160	Range 63-315 bar / 900-4600 psi standard setting 160 bar / 2300 psi
--------	------------	---

NOTE (*) - Codes are referred to **BSP** thread.

Parts ordering codes (proportional hydraulic control)

EL DLS180 / 6ZM 8IMF3 P1 (G3 - 100)

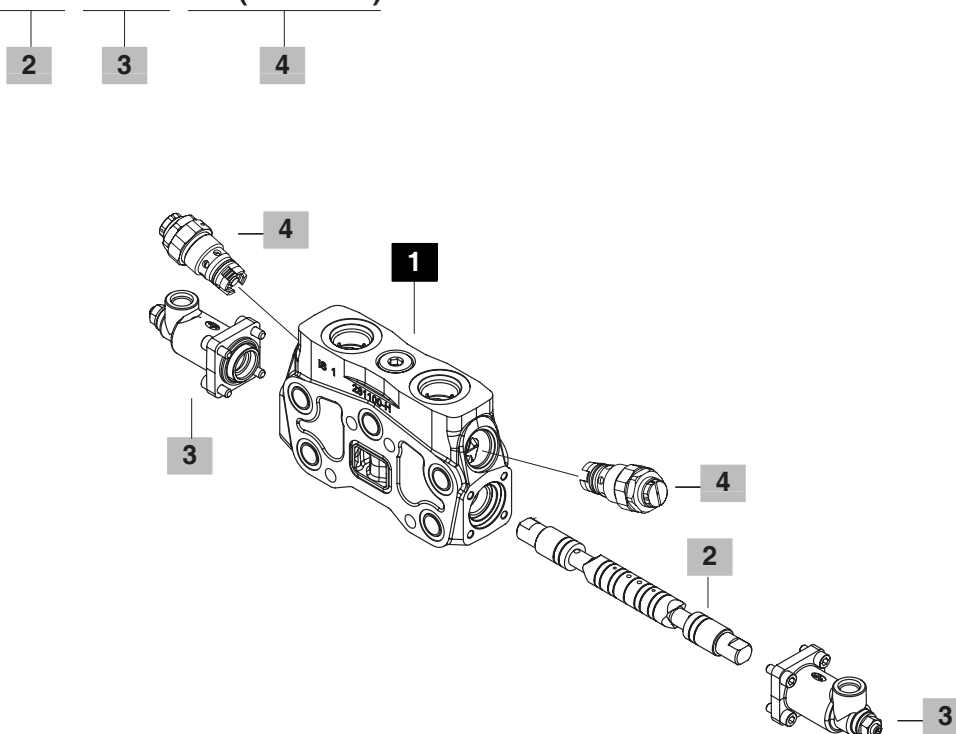
**1 Working section kit *** page 64

TIPO	CODE	DESCRIPTION
P/IM	5EL5183000A	Parallel circuit for hydraulic controls

2 Spools page 64

TYPE	CODE	DESCRIPTION
Double acting, 3 positions, with A and B closed in neutral position.		
6QM	3CU3550040	For flow 40 l/min - 10.57 Us gpm
6OM	3CU3550080	For flow 80 l/min - 21.13 Us gpm
6VM	3CU3550120	For flow 120 l/min - 31.70 Us gpm
6ZM	3CU3550140	For flow 140 l/min - 36.98 Us gpm
Double acting, 3 positions, with A and B to tank in neutral position.		
7VM	3CU3555120	For flow 120 l/min - 31.70 Us gpm
7ZM	3CU3555140	For flow 140 l/min - 36.98 Us gpm

3 Complete controls page 67

TYPE	CODE	DESCRIPTION
8IM	5IDR216300	Zama control kit for special spools and body kit without seals and ring. Range 5.8-19 bar / 84-270 psi
8IMF3	5IDR216303	Zama control kit with stroke limiters. Range 5.8-19 bar 84-270 psi
8IMO	5IDR216000	Steel control kit. Range 5.8-19 bar 84-270 psi
8IMOHF3	5IDR216303-H	Steel control kit with stroke limiters. Range 5.8-19 bar / 84-270 psi

4 Port valves page 46

TYPE	CODE	DESCRIPTION
Valves standard setting is referred to 10 l/min flow.		
P3T	XTAP530361	A and B ports valve blanking plugs, omitted from the description
C	3XCAR416100	Anti-cavitation valve
Anti-shock valve		
P(G2)	XCAR216115	Range 50-120 bar / 725-1750 psi standard setting 63 bar / 900 psi
P(G3)	XCAR216116	Range 100-250 bar / 1450-3600 psi standard setting 100 bar / 1450 psi
P(G4)	XCAR216117	Range 160-315 bar / 2300-4600 psi standard setting 200 bar / 2900 psi
Pilot hydraulic unloader valve		
PX	XCAR416301	Pilot hydraulic unloader valve
Anti-shock and anti-cavitation valve		
U(G2)	X011411099	Range 35-90 bar / 510-1300 psi standard setting 60 bar / 870 psi
U(G3)	X011411100	Range 100-250 bar / 1450-3600 psi standard setting 100 bar / 1800 psi
U(G4)	X011411101	Range 180-350 bar / 2600-5100 psi standard setting 200 bar / 2900 psi
Pilot operated anti-shock and anti-cavitation valve		
UXW(G)	X01141B160	Range 63-315 bar / 900-4600 psi standard setting 200 bar / 2900 psi

NOTE (*) - Codes are referred to **BSP** thread.

Dimensional data and hydraulic circuit

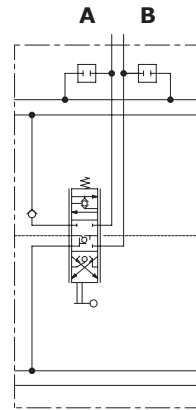
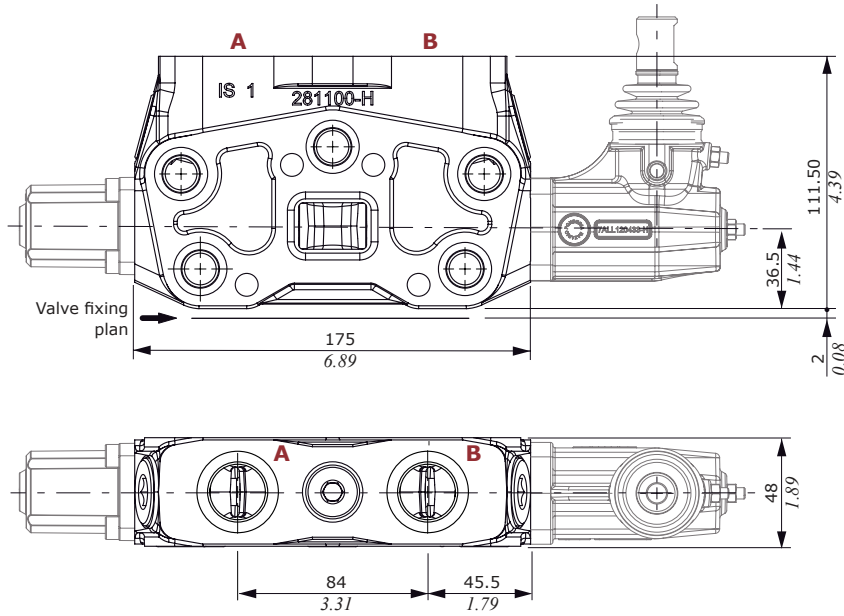

Description example:
6Z8LF3

Spools

Spool type 6Q/6O/6V/6Z

Double acting, 3 positions, with A and B closed in neutral position

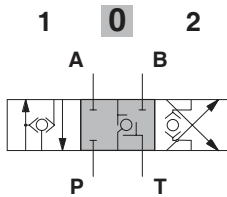

Spool stroke

position 1: + 7 mm (+ 0.28 in)
position 2: - 7 mm (- 0.28 in)

Spool type 7V/7Z

Double acting, 3 positions, with A and B to tank in neutral position

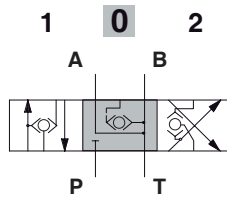

Spool stroke

position 1: + 7 mm (+ 0.28 in)
position 2: - 7 mm (- 0.28 in)

"A" side spool positioners

With friction type 7FT

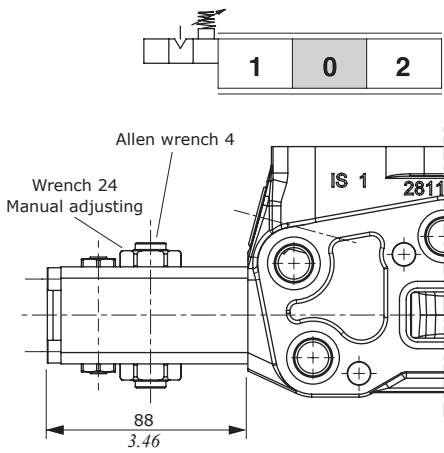

With spring return

Type 8MC

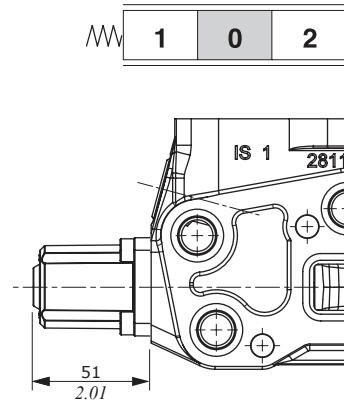

For "A" side spool positioners **9BZ**, **10BZ** and **11BZ** see page 33

8IZ proportional hydraulic control

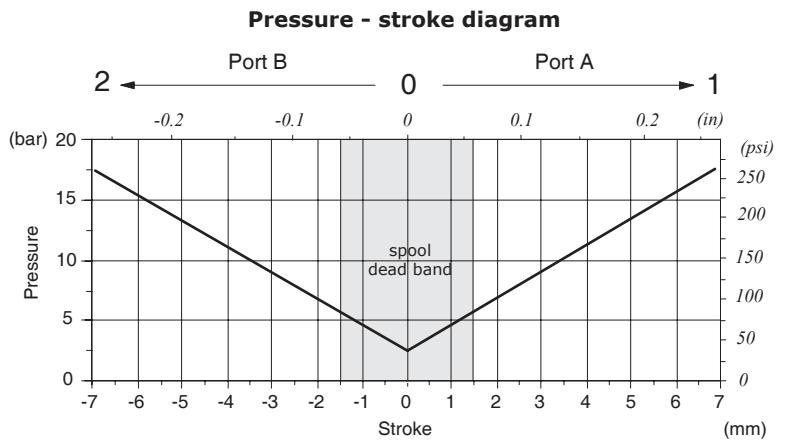
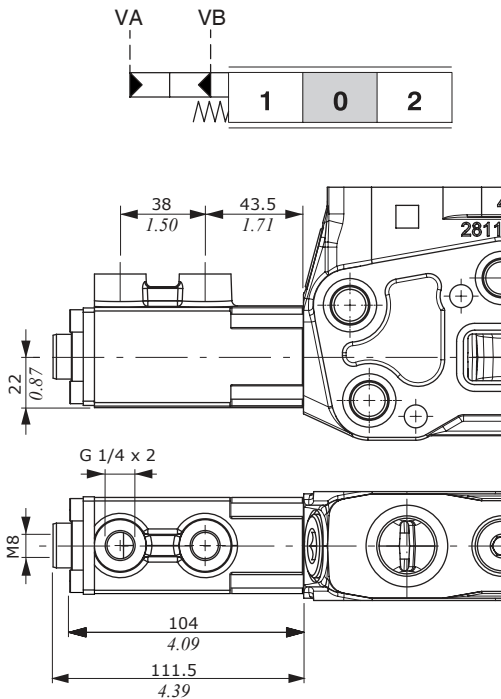

Features

- Pilot pressure : max. 100 bar / 1450 psi
- stroke : ± 7mm (± 0.28 in)

"B" side options

Lever control

L Type

Aluminium pivot box with protective rubber bellow.

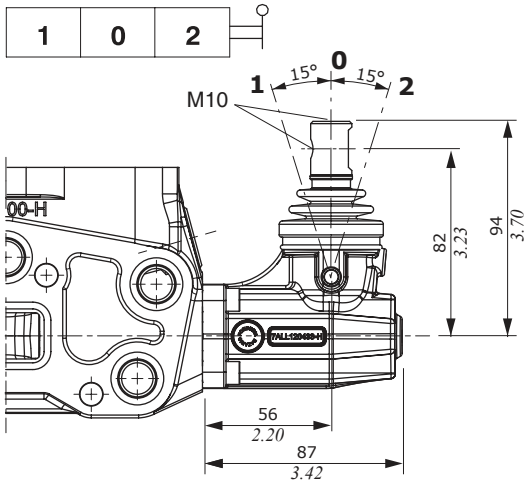

LF3 Type

With spool stroke adjustments in pos.1 and 2, (P→A), (P→B).

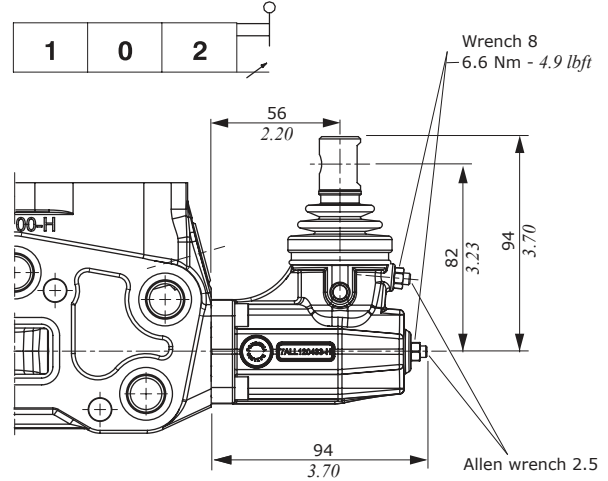

LA Type

Steel execution.

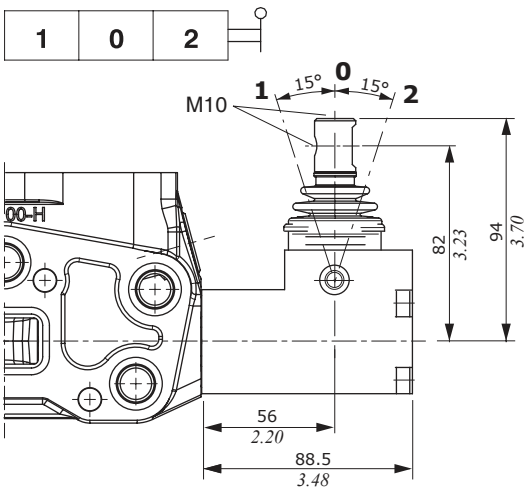

LAF3 Type

Steel execution with spool stroke adjustments.

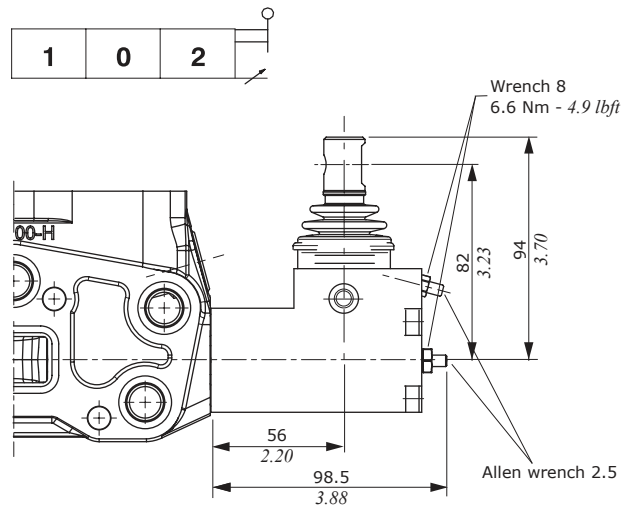

SLP type

Mechanical control with dust-proof plate kit.

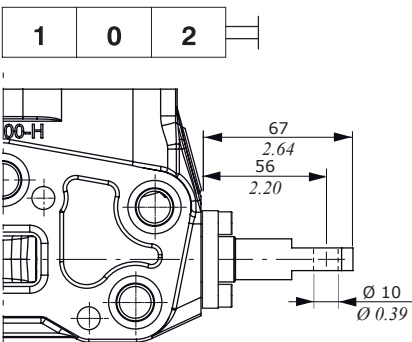

TQ cable remote control kit

For remote control with flexible cable.

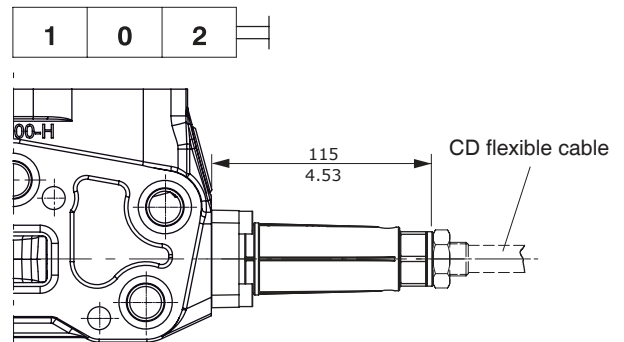

8IMOHF3 proportional hydraulic kit

For other complete controls see page 43.

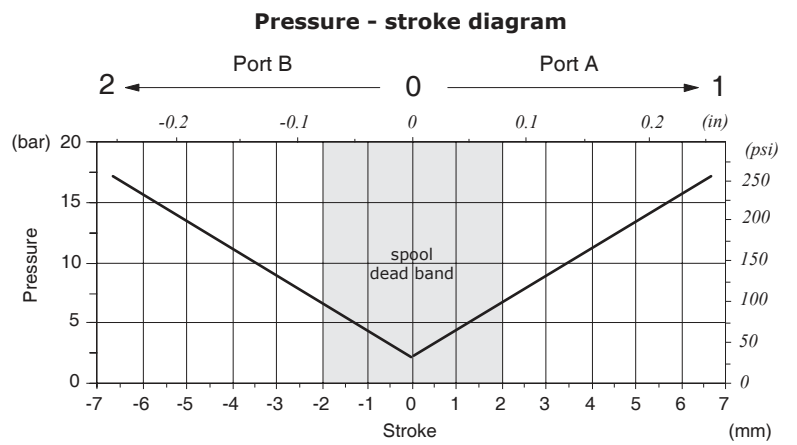
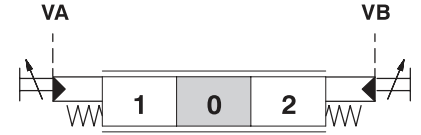
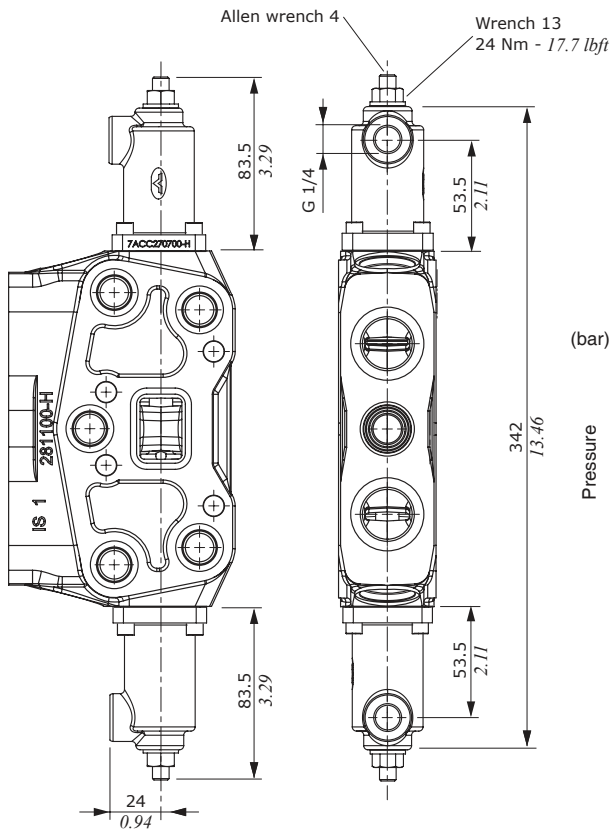

Features

Pilot pressure : max. 100 bar / 1450 psi

Dimensional data and hydraulic circuit

Type RF
with ports plugged

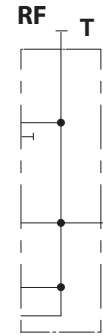
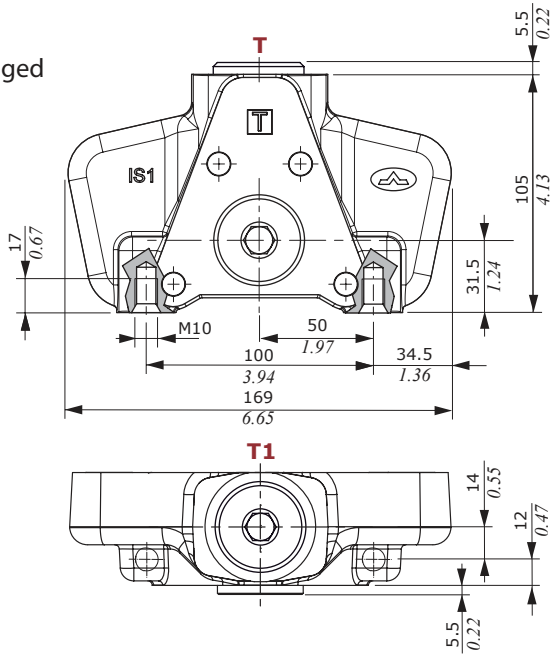

Type RD
upper outlet

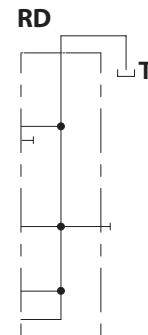
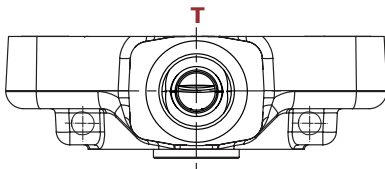

Type RC
side outlet

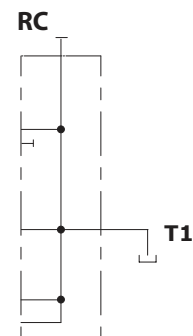
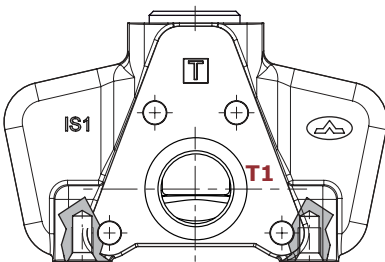

Installation and maintenance

The SDS180 and DLS180 valve are assembled and tested as per the technical specification of this catalogue.

Before the final installation on your equipment, follow the below recommendations:

- the valve can be assembled in any position; order to prevent working section deformation and spool sticking mount the product on a flat surface;
- In order to prevent the possibility of water entering the lever box and spool control kit, do not use high pressure wash down directly on the valve;
- prior to painting, ensure plastic port plugs are tightly in place.

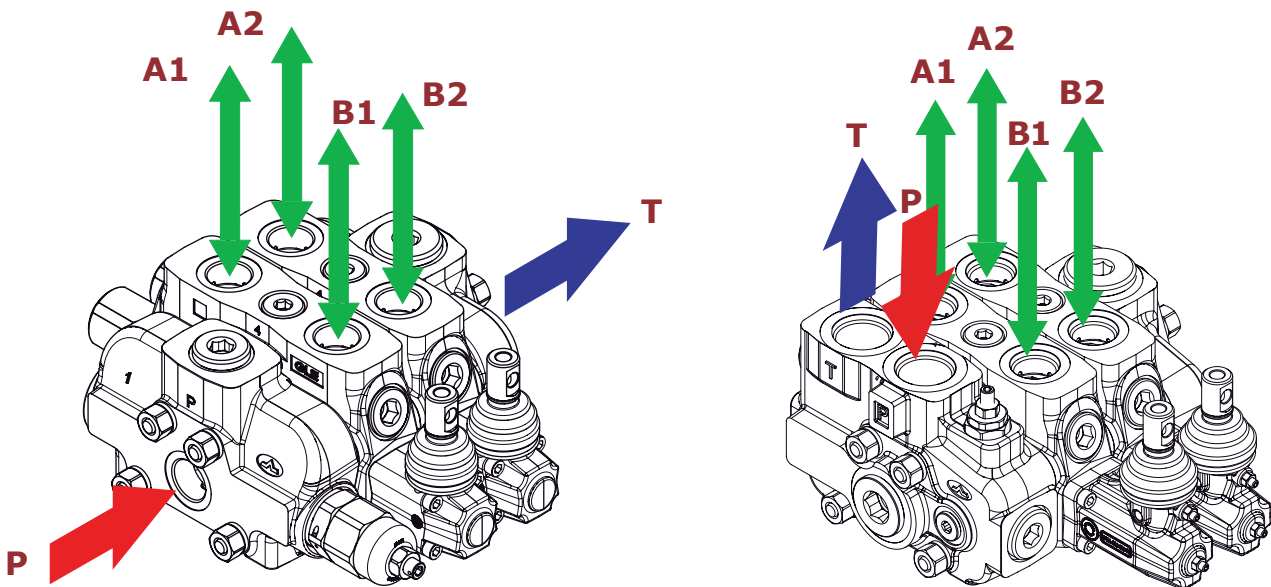

Fitting tightening torque - Nm / lbft

THREAD TYPE	port P	ports A, B	port T	Hydraulic pilot
BSP	G 3/4	G 3/4	G 1	G 1/4
With O-Ring seal	90 / 66.4	90 / 66.4	100 / 73.7	20 / 15.7
With copper washer	90 / 66.4	90 / 66.4	90 / 66.4	25 / 18.4
With steel and rubber washer	70 / 51.6	70 / 51.6	100 / 73.7	16 / 11.8
UN-UNF	1 5/16-12 (SAE 16)	1 1/16-12 (SAE 12)	1 5/16-12 (SAE 16)	9/16-18 (SAE 6)
With O-Ring seal	150 / 110.6	95 / 70.1	150 / 110.6	30 / 22.1

NOTE – These torque are recommended. Assembly tightening torque depends on many factors, including lubrication, coating and surface finish. The manufacturer shall be consulted.

Coils

Types and ordering codes

Coil type	Voltage	Connectors						
		ISO4400	Deutsch DT	AMP JPT	Packard Weatherpack	Packard Metri-pack	Flying leads (without conn.)	
BER	10 VDC	4SLE001000	-	-	-	-	-	
	12 VDC	4SLE001200 4SLE001217 ⁽³⁾	4SLE001201 ⁽⁵⁾	4SLE001209 ⁽³⁻⁵⁾	4SLE001203 ⁽⁵⁾	4SLE001210 ⁽²⁾	4SLE001214 ⁽²⁾	4SLE001207
			4SLE001202 ⁽⁶⁾	4SLE001216 ⁽³⁻⁶⁾	4SLE001211 ⁽³⁻⁵⁾	-	-	-
			4SLE001206 ⁽²⁾	4SLE002401 ⁽⁵⁾	4SLE002403 ⁽⁵⁾	-	-	4SLE002404
			4SLE002408 ⁽³⁾	4SLE002407 ⁽³⁻⁵⁾	-	-	-	-
	24 VDC	4SLE302400 ⁽¹⁾	4SLE002402 ⁽⁶⁾	-	-	-	-	
48 VDC	4SLE004800 4SLE304800 ⁽¹⁾	-	-	-	-	-		
110VDC	4SLE011000 4SLE311000 ⁽¹⁾	-	-	-	-	-		
220 VDC	4SLE022000 4SLE322000 ⁽¹⁾	-	-	-	-	-		
BE	12 VDC	4SL1000120	4SL1000123 ⁽⁶⁾ 4SL1000140 ⁽³⁻⁶⁾ 4SL1000124 ⁽²⁾	-	-	-	4SL1000122	
	24 VDC	4SL1000240 4SL1030240 ⁽¹⁾	4SL1002401 ⁽⁶⁾	-	-	-	-	
	110 VDC	4SL1011100 4SL1031100 ⁽¹⁾	-	-	-	-	-	
	220 VDC	4SL1022200 4SL1032200 ⁽¹⁾	-	-	-	-	-	
BT	10 VDC	4SL3000100	-	-	-	-	-	
	12 VDC	4SL3000120 4SL3000126 ⁽⁴⁾	4SL3000130 ⁽⁶⁾	4SL3000122 ⁽⁵⁾	4SL3000124 ⁽²⁾	4SL3000127 ⁽²⁾	4SL300012C	
			4SL3000134 ⁽³⁻⁶⁾	4SL30001200 ⁽³⁻⁵⁾	-	-	-	
	24 VDC	4SL3000240 4SL3030240 ⁽¹⁾	4SL3000249 ⁽⁶⁾ 4SL300024C ⁽³⁻⁶⁾	4SL3000248 ⁽⁵⁾	-	-	4SL3000246	
	26 VDC	4SL3000260	-	-	-	-	-	
	48 VDC	4SL3000480 4SL3030480 ⁽¹⁾	-	-	-	-	-	
110 VDC	4SL3001100 4SL3031100 ⁽¹⁾	-	-	-	-	-		
220 VDC	4SL3002200 4SL3032200 ⁽¹⁾	-	-	-	-	-		
BPV	12 VDC	4SLA001200	-	-	-	-	-	
	24 VDC	4SLA002400	-	-	-	-	-	
Mating connectors (For connector with rectifier see following table)		4CN1009995	5CON140031	5CON003	5CON001	5CON017	-	

Notes: (1) supply with AC and use only with rectifier connector - (2) with flying leads - (3) with bidirectional diode - (5) with unidirectional diode - (6) integrated perpendicular type - (6) integrated parallel type

Voltage	ISO 4400 mating connector with rectifier			
	coil type BER	coil type BT	coil type BPV	coil type BE
24 VDC	4CN1010240	4CN3010240	-	4CN1010240
48 VDC	4CN1010480	4CN3010480	-	4CN1010480
110 VDC	4CN1011100	4CN3011100	-	4CN1011100
220 VDC	4CN1012200	4CN3012200	-	4CN1012200

Dimensions and features

Type BER

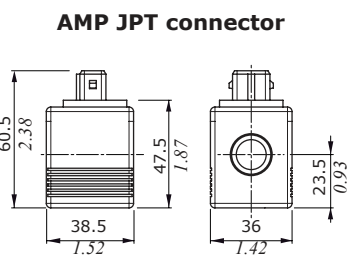
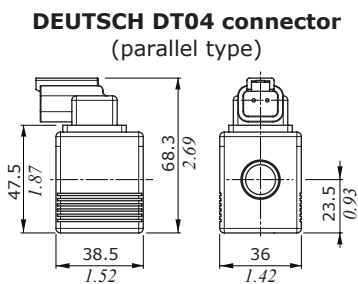
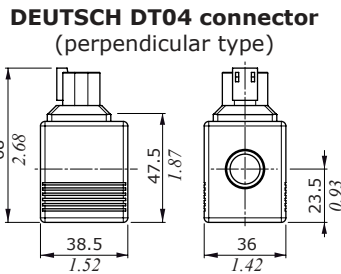
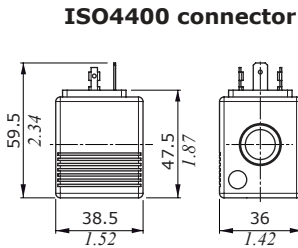

Features

- Nominal voltage tolerance : $\pm 10\%$
- Power rating : 19.2 W - 10/12/24/48/
110/220 VDC
: 19 W - 24/110/220 RAC
: 19.2 W - 48 RAC
- Max. operating current . . . : 1.9 A - 10 VDC
: 1.61 A - 12 VDC
: 0.80 A - 24 VDC
: 0.40 A - 48 VDC
: 0.17 A - 110 VDC
: 0.09 A - 220 VDC
: 0.89 A - 24 RAC
: 0.45 A - 48 RAC
: 0.19 A - 110 RAC
: 0.09 A - 220 RAC
- Coil insulation : Class H (180°C - 356°F)
- Weather protection : IP65 - ISO4400
: IP69K - Deutsch DT
: IP65 - AMP JPT
: IP67 - Weatherpack
: IP67 - Metri-pack
- Insertion : 100%

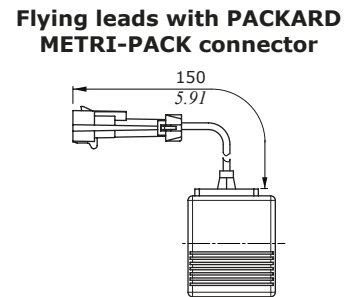
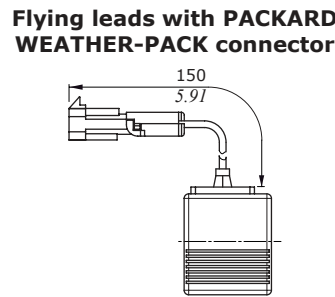
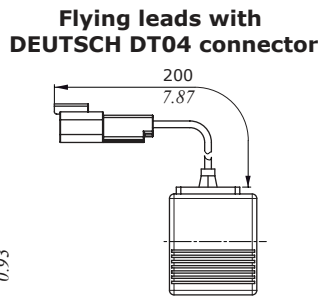
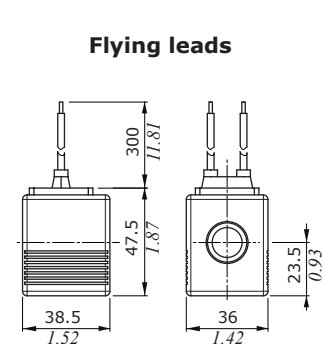

Type BE

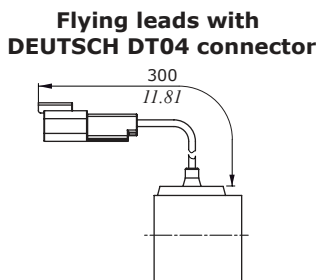
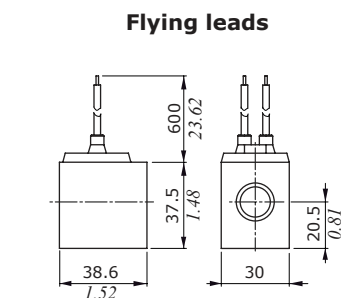
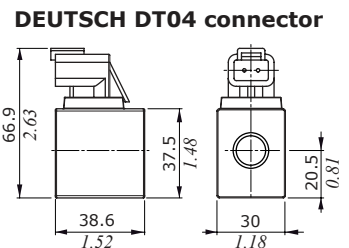
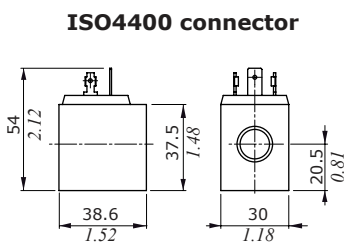

Features

- Nominal voltage tolerance : $\pm 10\%$
- Power rating : 18.7 W - 12 VDC
: 18.6 W - 24 VDC
: 17.3 W - 110 VDC
: 15.7 W - 220 VDC
: 18.3 W - 24 RAC
: 16 W - 110 RAC
: 16 W - 220 RAC
- Max. operating current . . . : 1.56 A - 12 VDC
: 0.77 A - 24 VDC
: 0.157 A - 110 VDC
: 0.08 A - 220 VDC
: 0.85 A - 24 RAC
: 0.16 A - 110 RAC
: 0.08 A - 220 RAC
- Coil insulation : Class F (155°C - 311°F)
- Weather protection : IP65 - ISO4400
: IP69K - Deutsch DT
- Insertion : 100%

Coils

Dimensions and features

Type BT

ISO4400 connector

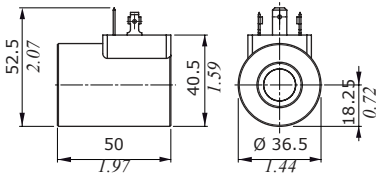

AMP JPT connector

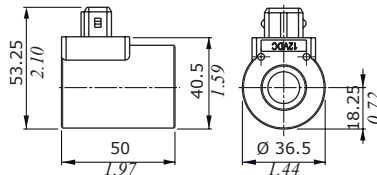

Flying leads

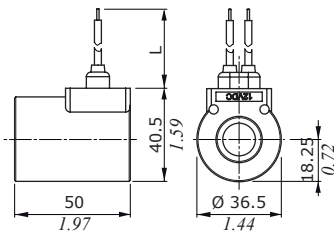

DEUTSCH DT04 connector

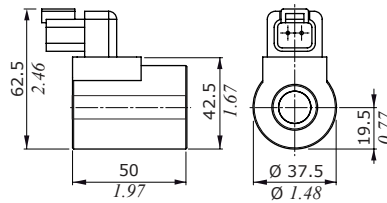

Coil type	Dimension L	
	(mm)	(in)
12VDC	247	9.72
24VDC	307	12.09

Features

- Nominal voltage tolerance : ±10%
- Power rating : 19 W - 10 VDC
- : 21 W - 12/24/26 VDC
- : 20.3 W - 48 VDC
- : 17.3 W - 110 VDC
- : 17.7 W - 220 VDC
- : 19.9 W - 24 RAC
- : 20.7 W - 48 RAC
- : 20 W - 110 / 220 RAC
- Max. operating current . . : 1.9 A - 10 VDC
- : 1.77 A - 12 VDC
- : 0.89 A - 24VDC
- : 0.84 A - 26 VDC
- : 0.43 A - 48 VDC
- : 0.16 A - 110 VDC
- : 0.08 A - 220 VDC
- : 0.93 A - 24 RAC
- : 0.47 A - 48 RAC
- : 0.18 A - 110 RAC
- : 0.09 A - 220 RAC
- Coil insulation : Class F (155°C - 311°F)
- Weather protection : IP65 - ISO4400
- : IP69K - Deutsch DT
- : IP65 - AMP JPT
- : IP67 - Weatherpack
- : IP67 - Metri-pack
- Insertion : 100%

Flying leads with DEUTSCH DT04 connector

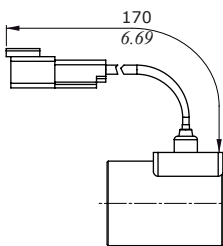

Flying leads with PACKARD WEATHER-PACK connector

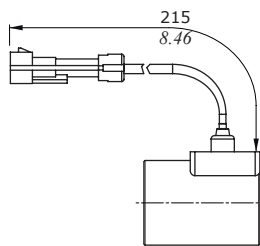

Flying leads with PACKARD METRI-PACK connector

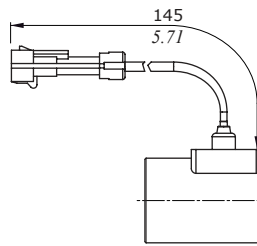

Type BPV

ISO4400 connector

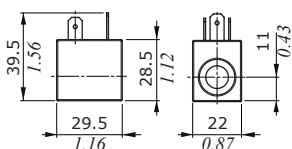

Flying leads

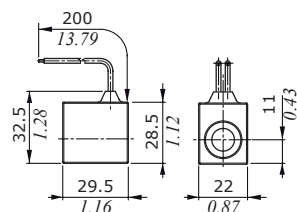

Features

- Nominal voltage tolerance : ±10%
- Power rating : 8 W - 12/24 VDC
- Max. operating current . . : 0.67 A - 12 VDC
- : 0.33 A - 24VDC
- Coil Insulation : Class H (180°C - 356°F)
- Weather protection : IP65 - ISO4400
- Insertion : 100%

Fixing brackets

They are available for SDS180 directional valves and they are zinc plated steel, complete with mounting screws.

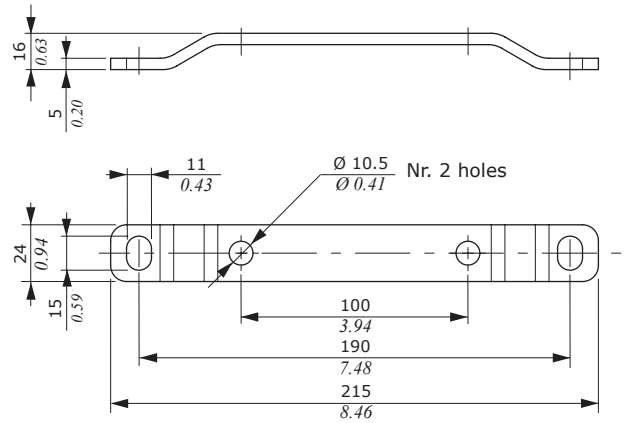
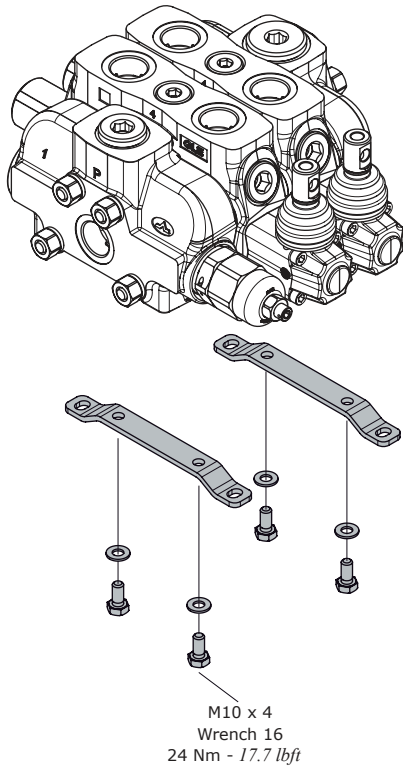

Painting

SDS180 valve can be supplied with one coat of black paint (**CVN** configuration).

Description example: SDS180/2/AC(YG3-120)/18L/18L/RC-**<CVN>**

NOTE - For different colour consult Sales Department.

6th edition July 2013

WWW.WALVOIL.COM



D1WWEB01E

