



MONOBLOCK
DIRECTIONAL CONTROL VALVE

SD 18



 **walvoil**
HYDRAULIC CONTROL SYSTEMS

Features

Simple, compact and heavy duty designed monoblock from 1 to 6 sections for open and closed centre hydraulic systems.

Fitted with a direct or pilot operated main pressure relief valve.

Parallel circuit.

Optional carry-over port.

Diemeter 25 mm - 0.98 in interchangeable spools.

A wide variety of service port valves.

Available manual, pneumatic, electro-pneumatic, hydraulic and electro-hydraulic spool control kits.

Additional information

This catalogue shows the product in the most standard configurations.

Please contact Customer Service Dpt. for more detailed information or special request.

WARNING!

All specifications of this catalogue refer to the standard product at this date.

Walvoil, oriented to a continuous improvement, reserves the right to discontinue, modify or revise the specifications, without notice.

WALVOIL IS NOT RESPONSIBLE FOR ANY DAMAGE CAUSED BY AN
INCORRECT USE OF THE PRODUCT.

5th edition October 2001:

This edition supercedes all prior documents.

Contents

Working conditions	4
Dimensional data	5
Hydraulic circuit	6
Performance data	7
Ordering codes	8
Inlet relief options	10
Spool options	12
“A” side spool positioners	16
“B” side options	23
Proportional hydraulic spool control	24
Port relief options	26
Outlet port conversion	28
Installation and maintenance	29

SD18

Working conditions

This catalogue shows technical specifications and diagrams measured with mineral oil of 46 mm²/s - 46 cSt viscosity at 40°C temperature.

Nominal flow rating		160 l/min	
Operating pressure (maximum)		250 bar	3620 psi
Max. back pressure	<i>on outlet port T</i>	25 bar	360 psi
Internal leakage A(B)→T	<i>Δp=100 bar - 1450 psi fluid and valve at 40°C</i>	4 cm ³ /min	0.24 in ³ /min
Hydraulic fluid		Mineral oil	
Fluid temperature	<i>with NBR seals</i>	from -20° to 80°C	
	<i>with FPM (VITON) seals</i>	from -20° to 100°C	
Viscosity	<i>operating range</i>	from 15 to 75 mm ² /s	<i>from 15 to 75 cSt</i>
	<i>min.</i>	12 mm ² /s	12 cSt
	<i>max.</i>	400 mm ² /s	400 cSt
Max level of contamination		19/16 - ISO 4406	
Ambient temperature		from -40° to 60°C	

NOTE - For different conditions please contact Customer Service.

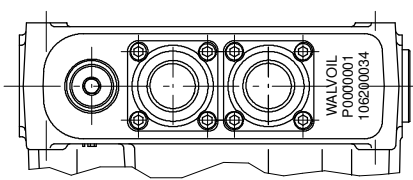
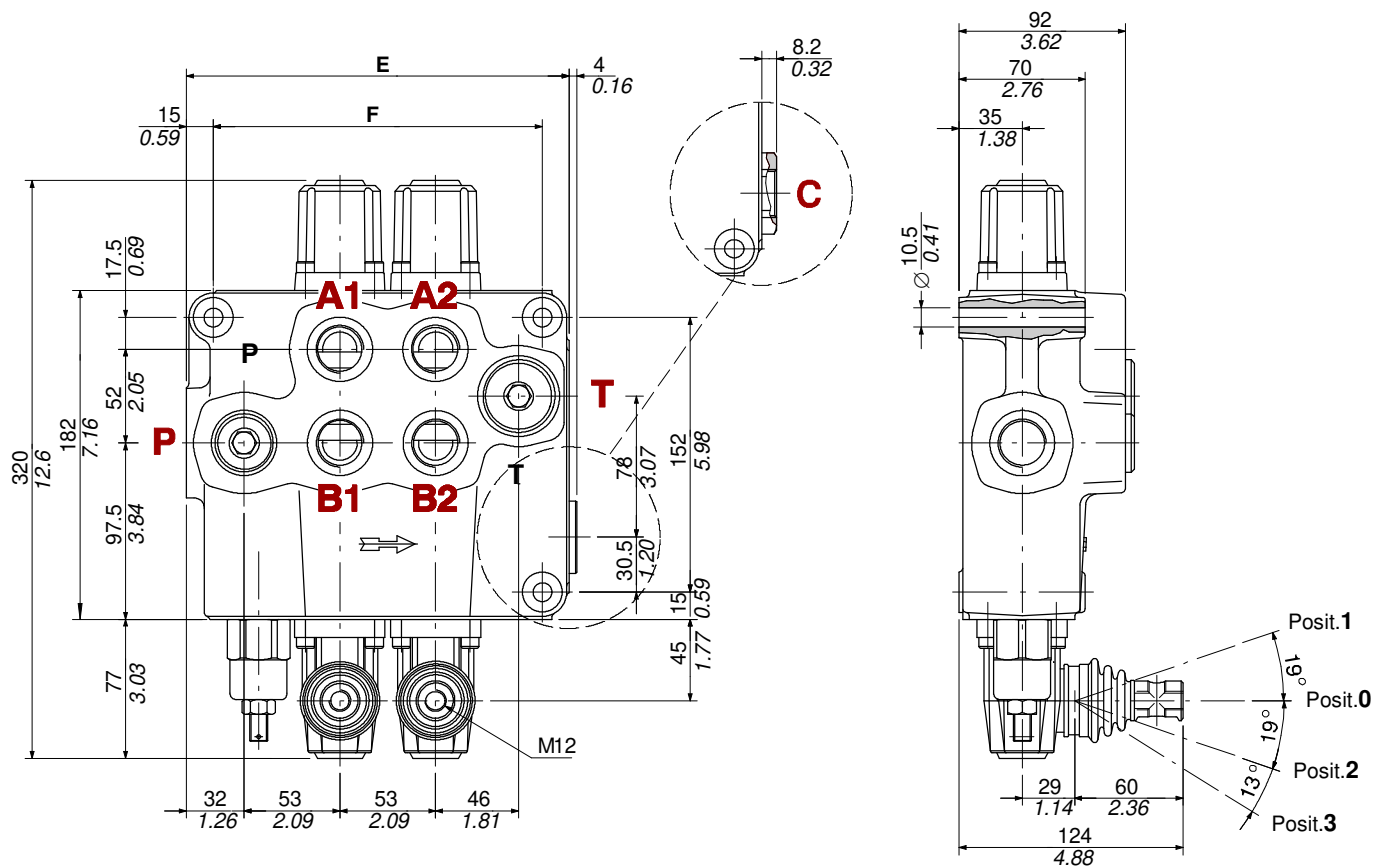

WALVOIL
P0000001
106200034

Production batch :
 P00 = production year (2000)
 00001 = progressive number
 Valve code

TYPE	E		F		Weight	
	mm	in	mm	in	kg	lb
SD18/1-P	159	6.26	129	5.08	13.2	29.1
SD18/2-P	212	8.35	182	7.17	18.6	41
SD18/3-P	265	10.4	235	9.25	23.5	51.8

TYPE	E		F		Weight	
	mm	in	mm	in	kg	lb
SD18/4-P	318	12.5	288	11.3	28.8	63.5
SD18/5-P	371	14.6	341	13.4	34.1	75.2
SD18/6-P	424	16.7	394	15.5	39.4	86.9

Standard threads

PORT	BSP (ISO 228/1)	UN-UNF (ISO 11926-1)
Inlet P and carry-over C	G 3/4	1 5/16-12 UN-2B (SAE 16)
A and B ports	G 3/4	1 1/16-12 UN-2B (SAE 12)
Outlet T	G 1	1 5/16-12 UN-2B (SAE 16)
PILOT PORTS		
Hydraulic	G 1/4	9/16-18 UNF-2B (SAE 6)
Pneumatic	NPTF 1/8-27	NPTF 1/8-27

SD18

Hydraulic circuit

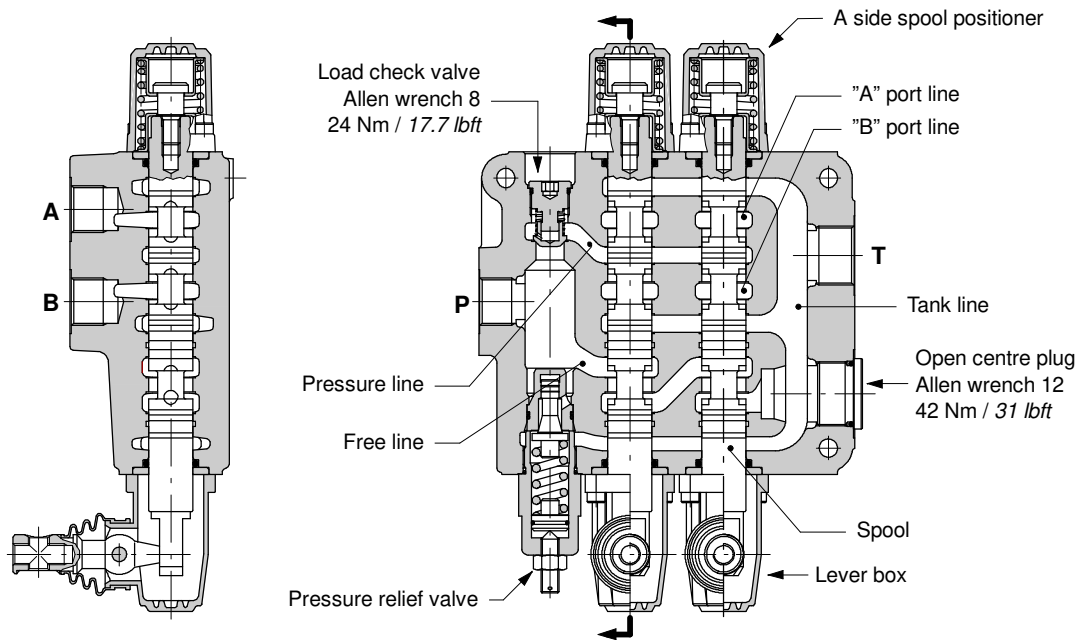

Standard configuration

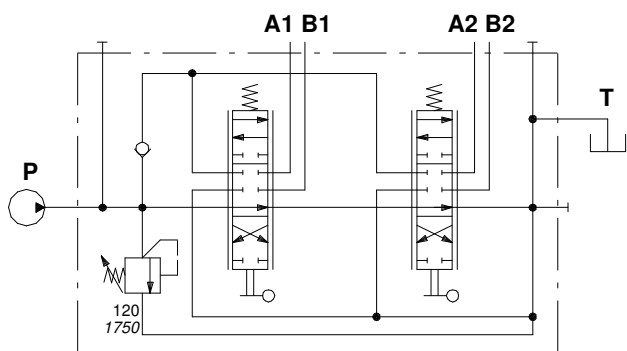

Ex.: SD18/2-P(KG3-120)/18L/18L/AET

Upper inlet and outlet ports configuration

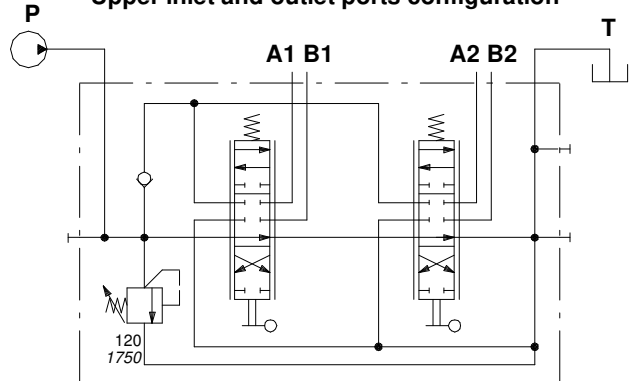

Ex.: SD18/2-P(KG3-120)/18L/18L/AET-PSA

Performance data (pressure drop vs. flow)

Open centre

From side inlet to side outlet.

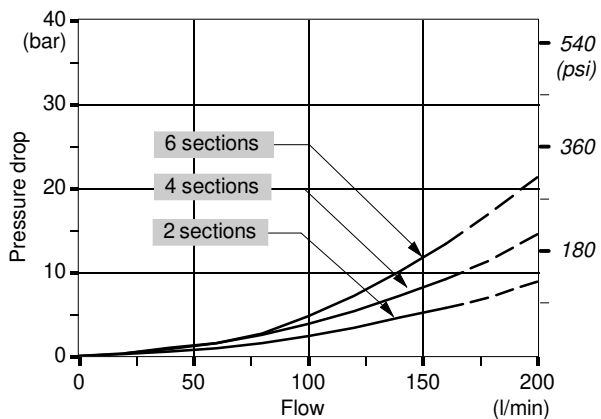
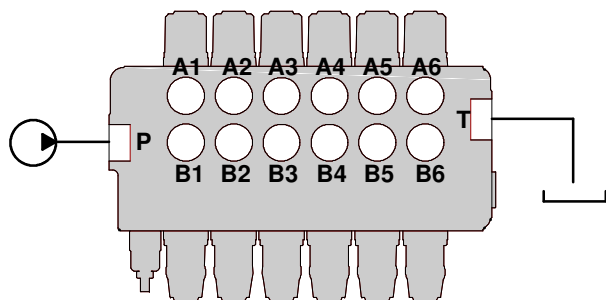

Inlet to work port

From side inlet to A port (spool in position 1) or B port (spool in position 2).

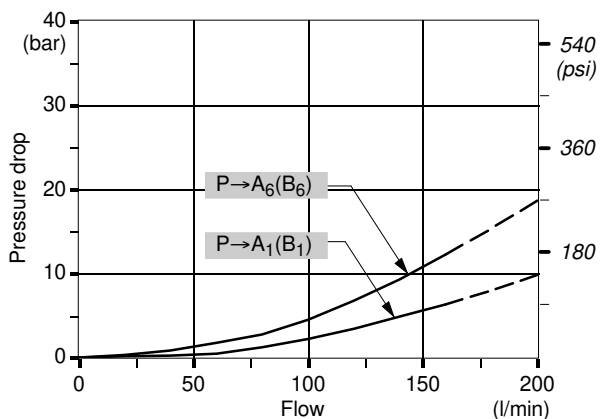
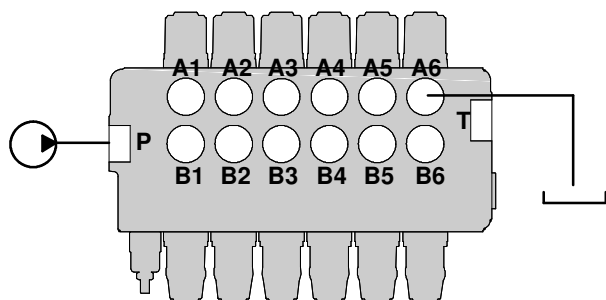

Work port to outlet

From A port (spool in position 2) or B port (spool in position 1) to side outlet.

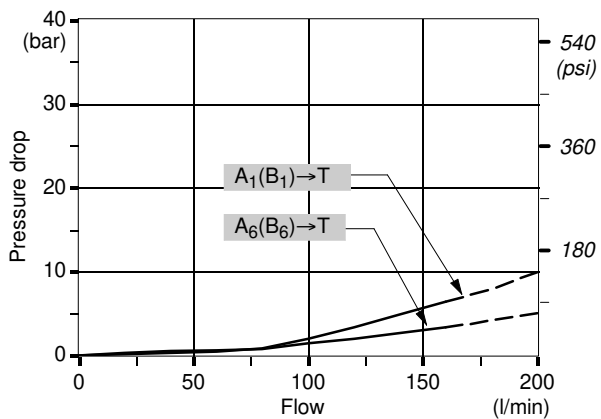
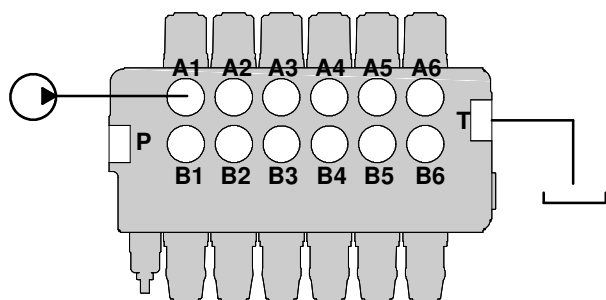

NOTE - Measured with spool type 1.

SD18

Ordering codes

Pressure relief valve setting in bar ←

Ex.: SD18/ **2 - P** (**KG3 - 120**) / **1 8 L** / **1C 8IM . P3(G3 - 120)** / **AET - PSA ***

1st section following section

1. 2. 3. 4. 5. 6. 7. 8. 9.

→ Port relief valve setting in bar

1. Body kits *

TYPE CODE DESCRIPTION

Without service port valves prearrangement

1-P	5KC1713000	1 section
2-P	5KC1723000	2 sections
3-P	5KC1743000	3 sections
4-P	5KC1763000	4 sections
5-P	5KC1783000	5 sections
6-P	5KC1803000	6 sections

Include body, seals, rings and load check valve.

2. Inlet relief options

page 10

TYPE CODE DESCRIPTION

VMD20/1 direct pressure relief valve type K (standard)

(KG2-80) 5KIT120112 Range 25 to 80 bar / 360 to 1150 psi
standard setting 80 bar / 1150 psi

(KG3-120) 5KIT120113 Range 63 to 200 bar / 900 to 2900 psi
standard setting 120 bar / 1750 psi

(KG4-220) 5KIT120114 Range 160 to 250 bar / 2300 to 3600 psi
standard setting 220 bar / 3200 psi

VMP20/1 pilot operated pressure relief valve type X

(XG-120) X007211120 Range 63 to 250 bar / 900 to 3600 psi
standard setting 120 bar / 1750 psi

Standard setting is referred to 10 l/min flow.

SV 3XTAP535410 Relief valve blanking plug

3. Spools

page 12

TYPE CODE CIRCUIT DESCRIPTION

1	3CU1610130	Double acting, 3 positions, with A and B closed in neutral position
2	3CU1625130	Double acting, 3 positions, with A and B open to tank in neutral position
3	3CU1631130	Single acting on A, 3 positions, B plugged requires G3/4 plug (see part I)
4	3CU1635130	Single acting on B, 3 positions, A plugged requires G3/4 plug (see part I)

Spools for 8IM hydraulic control

1C 3CU1610400 As type 1

2C 3CU1625400 As type 2

3C 3CU1631400 As type 3

Special spools: need special body kit

5 3CU1641130 Double acting, 4 positions, with A and B to tank in 4th position (float); for type 13 spool positioner

8F 3CU1661100 Double acting, 3 positions, with regenerative in position 2

NOTE (*) - Items are referred to **BSP** thread.

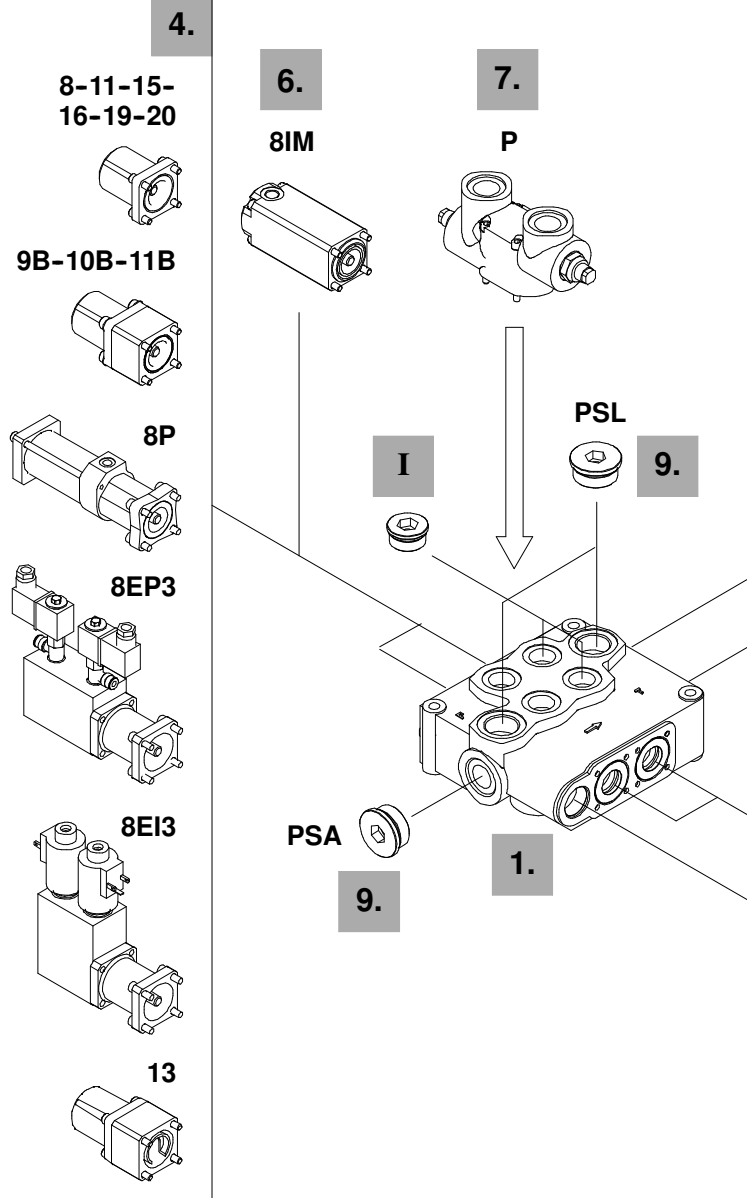

4. "A" side spool positioners

page 16

TYPE CODE DESCRIPTION

8	5V08120000	With spring return in neutral position
9B	5V09120000	With detent in position 1 and spring return neutral position
10B	5V09120000	With detent in position 2 and spring return neutral position
11B	5V11220000	With detent in positions 1 and 2, spring return neutral position

..... to be continued on next page

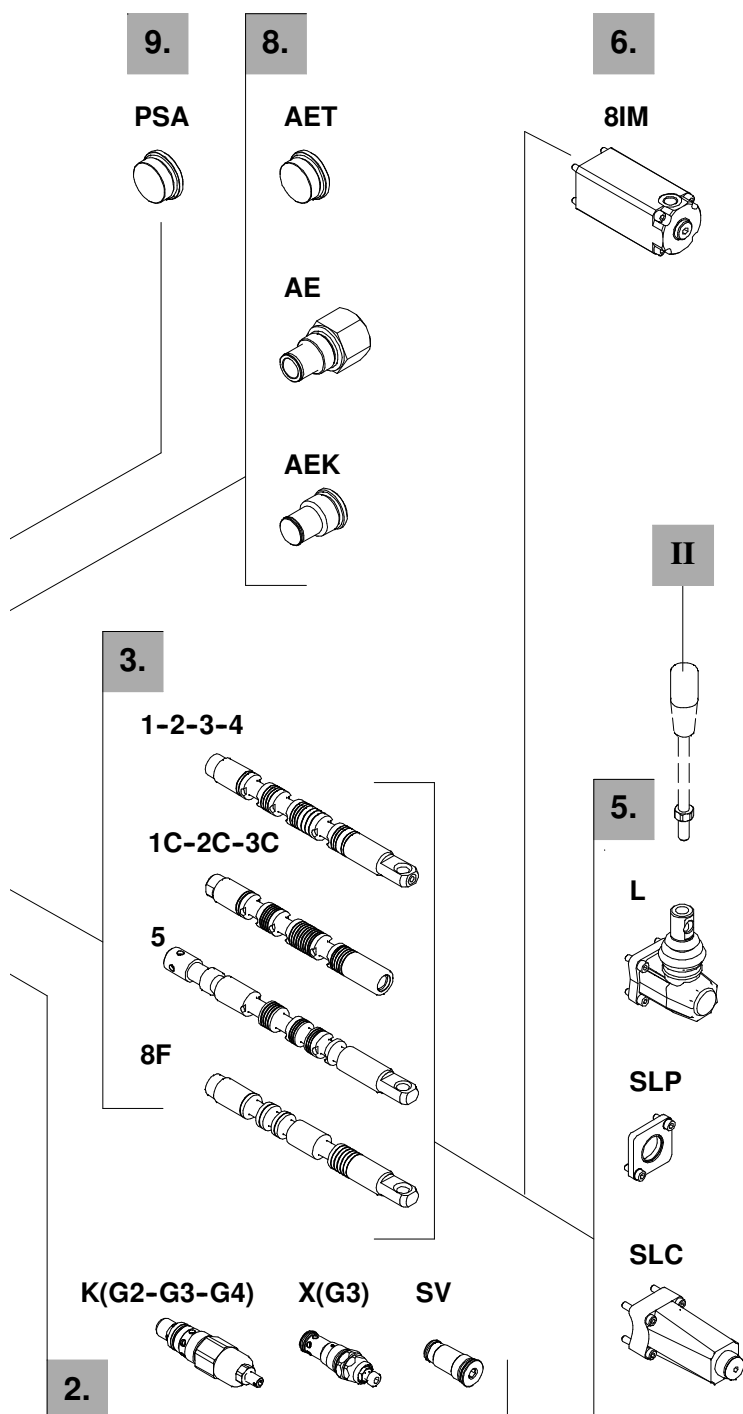

NOTE - Spools and positioners with the same symbol must be assembled together.

4. "A" side spool positioners *page 16*

TYPE	CODE	DESCRIPTION
11	5V11120000	With detent in positions 1, 0 and 2
15	5V15120000	With detent in positions 1 and 0
16	5V16120000	With detent in positions 2 and 0
19	5V19120000	With spring return in position 0 from 1
20	5V19120000	With spring return in position 0 from 2
8P	5V08120701	ON/OFF pneumatic kit
8EP3	5V08120735	12 VDC ON/OFF electro-pneumatic kit
	5V08120736	24 VDC ON/OFF electro-pneumatic kit
8E13	5V08120350	12 VDC ON/OFF electro-hydraulic kit
	5V08120351	24 VDC ON/OFF electro-hydraulic kit
Special positioner		
13	5V13020000	With detent in position 3 and spring return neutral position, for spool type 5

5. "B" side spool control kits *page 23*

TYPE	CODE	DESCRIPTION
L	5LEV120000	Standard lever
SLP	5COP120000	Without lever, with dust-proof plate
SLC	5COP220000	Without lever, with cap

6. Hydraulic spool control kit * *page 24*

TYPE	CODE	DESCRIPTION
Need special body kit		
8IM	5IDR220000	Proportional hydraulic operated with spring return in position 0, requires spools type C

7. Port relief options * *page 26*

TYPE	CODE	DESCRIPTION
Kit with anti-shock: need special body kit		
Range from 80 to 200 bar / 1150 to 2900 psi		
P1(G3-100)	606001000	Mounted on port A
P2(G3-100)	606001000	Mounted on port B
P3(G3-100)	606001100	Mounted on ports A and B
Standard setting is 100 bar - 1450 psi to 10 l/min flow.		

8. Outlet port conversion * *page 28*

TYPE	CODE	DESCRIPTION
AET	3XTAP640250	Open centre plug
AE	3XGIU541600	G3/4 carry-over sleeve
AEK	3XTAP540560	Closed centre plug

9. Inlet and outlet selection * *page 6*

TYPE	CODE	DESCRIPTION
PSL	3XTAP732200	Nr.1 G3/4 plug for side inlet
	3XTAP740210	Nr.1 G1 plug for side outlet
PSA	3XTAP732200	Nr.1 G3/4 plug for upper inlet
	3XTAP740210	Nr.1 G1 plug for upper outlet

I Ports plug *

TYPE	CODE	DESCRIPTION
G3/4	3XTAP732200	For single acting (spools type 3 and 4)

II Optional handlever

TYPE	CODE	DESCRIPTION
AL01/M12x250	170013025	For L lever box L= 250 mm / 9.84 in

Inlet relief options

Direct pressure relief valve

VMD20 (K G 3 - 120)

- Pressure setting in bar (standard 120 / 1750 psi)
- Spring type (2, 3, 4).
- Adjustment type (G, H)

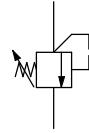

Adjustment type

G: with screw

H: valve set and locked

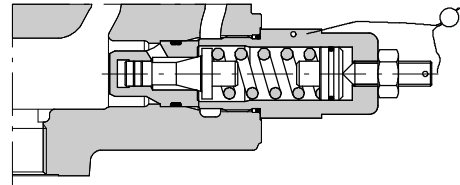
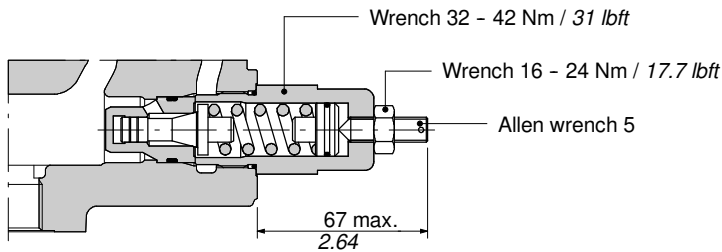

Performance data

Spring nr. 2 (green band)

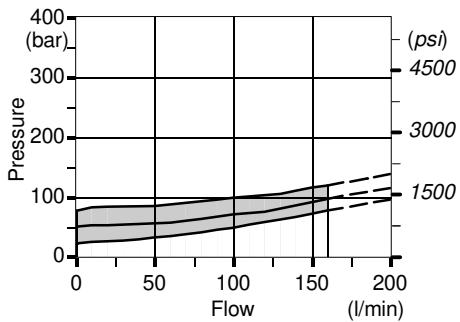

Spring nr. 3 (blue band)

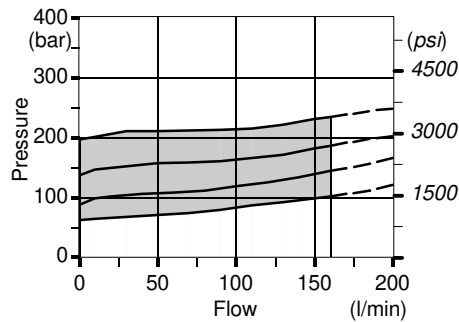

Spring nr. 4 (red band)

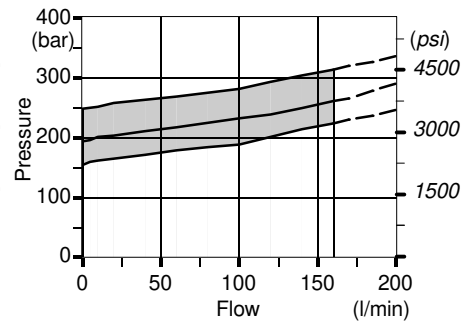

Response time

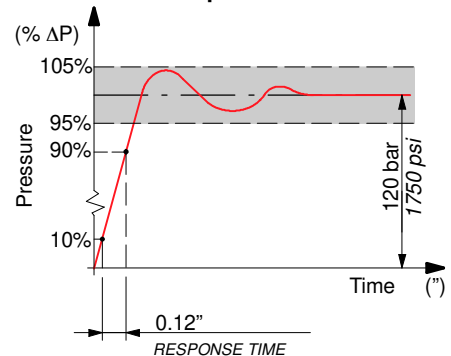

Pilot operated pressure relief valve

VMP20 (X G - 120)

Pressure setting in bar (standard 120 / 1750 psi)
Adjustment type (G, H)

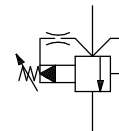

Adjustment type

G: with screw

H: valve set and locked

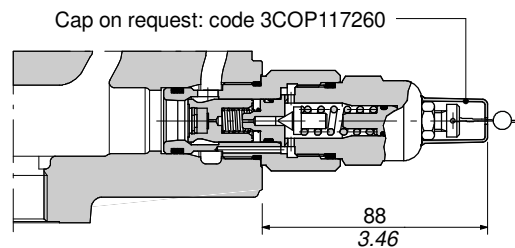
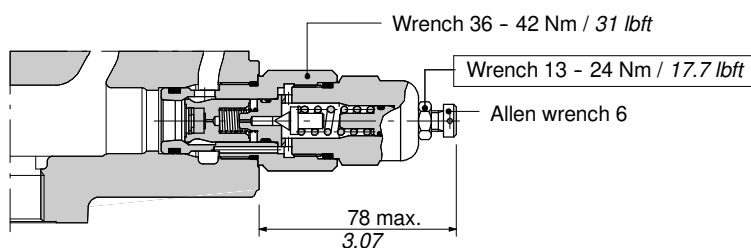

Performance data

Range setting

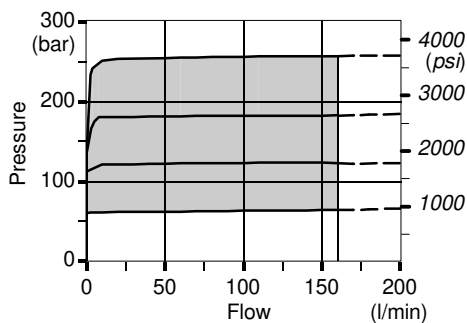

Response time

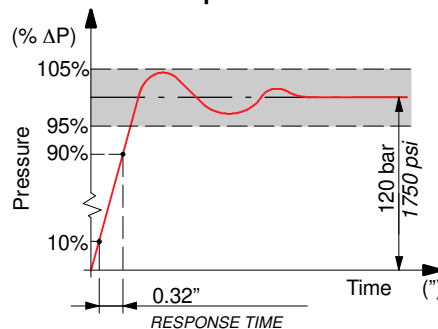

SV: relief valve blanking plug

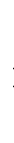
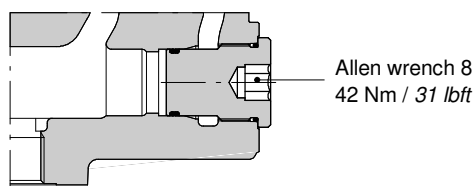

SD18

Spool options

Type 1

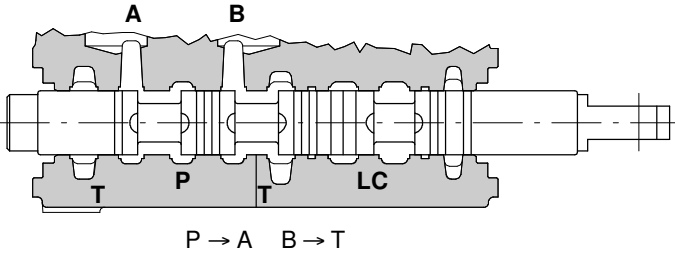

stroke = + 10 mm
+ 0.39 in

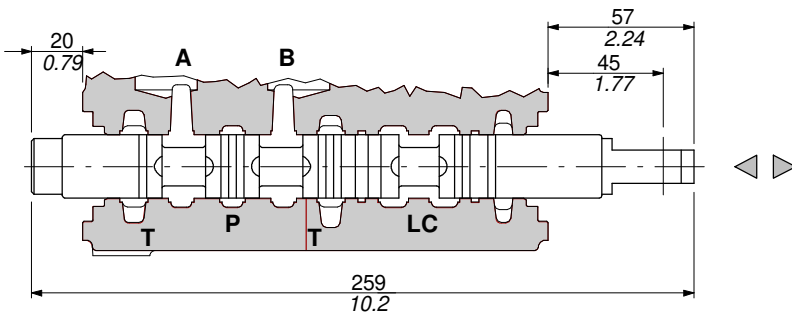
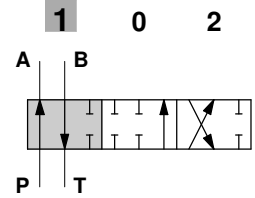

P-A-B-T closed, with flow through line (LC) open

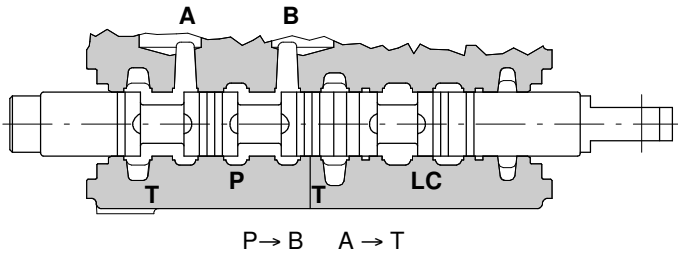
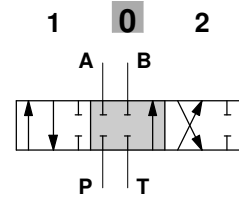

stroke = - 10 mm
- 0.39 in

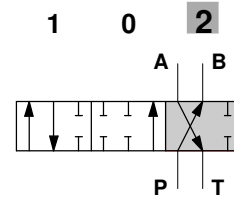

Performance data

Spool metering P → A(B)

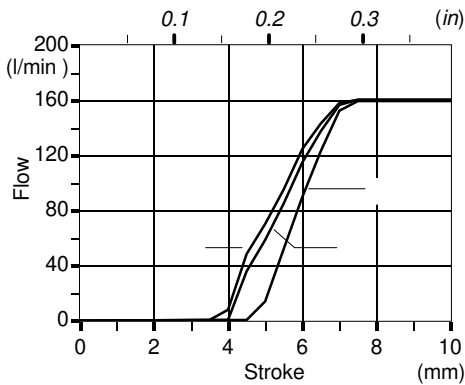

Q = 160l/min

P (on ports) = 63bar/900psi
P (on ports) = 100bar/1450psi
P (on ports) = 250bar/3600psi

Spool metering A(B) → T

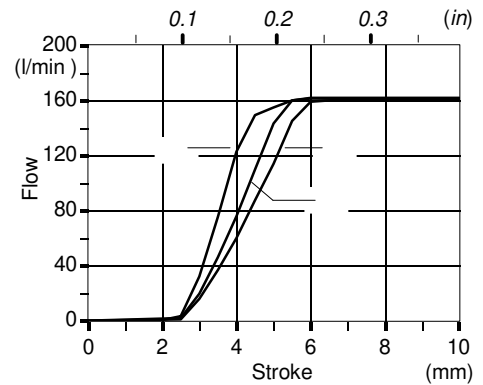

Type 2

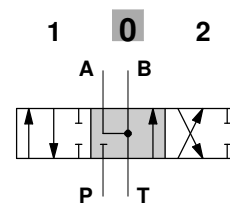
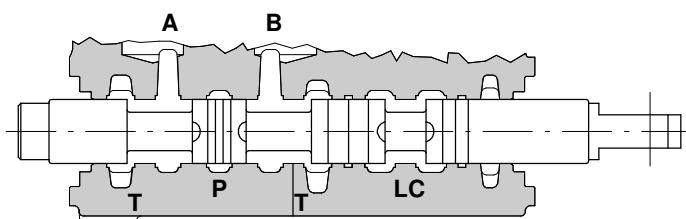

Type 3

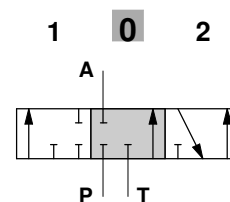
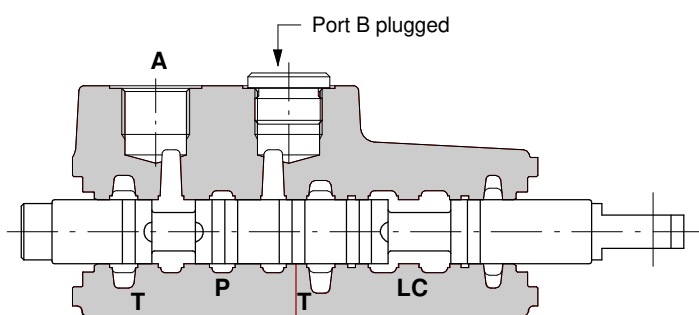

Type 4

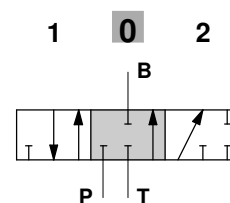
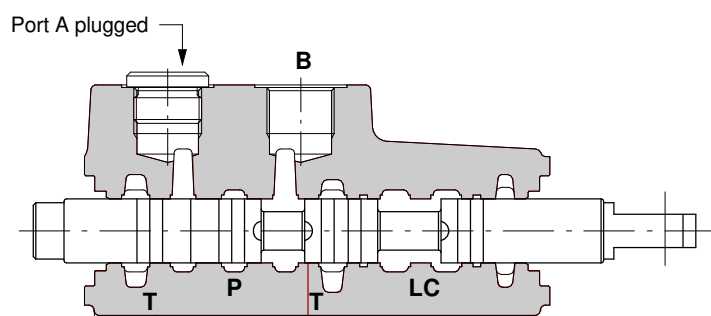

SD18

Spool options

Type 5

This spool needs special body with extra machining and must be used only with spool positioner type 13 (see page 19).

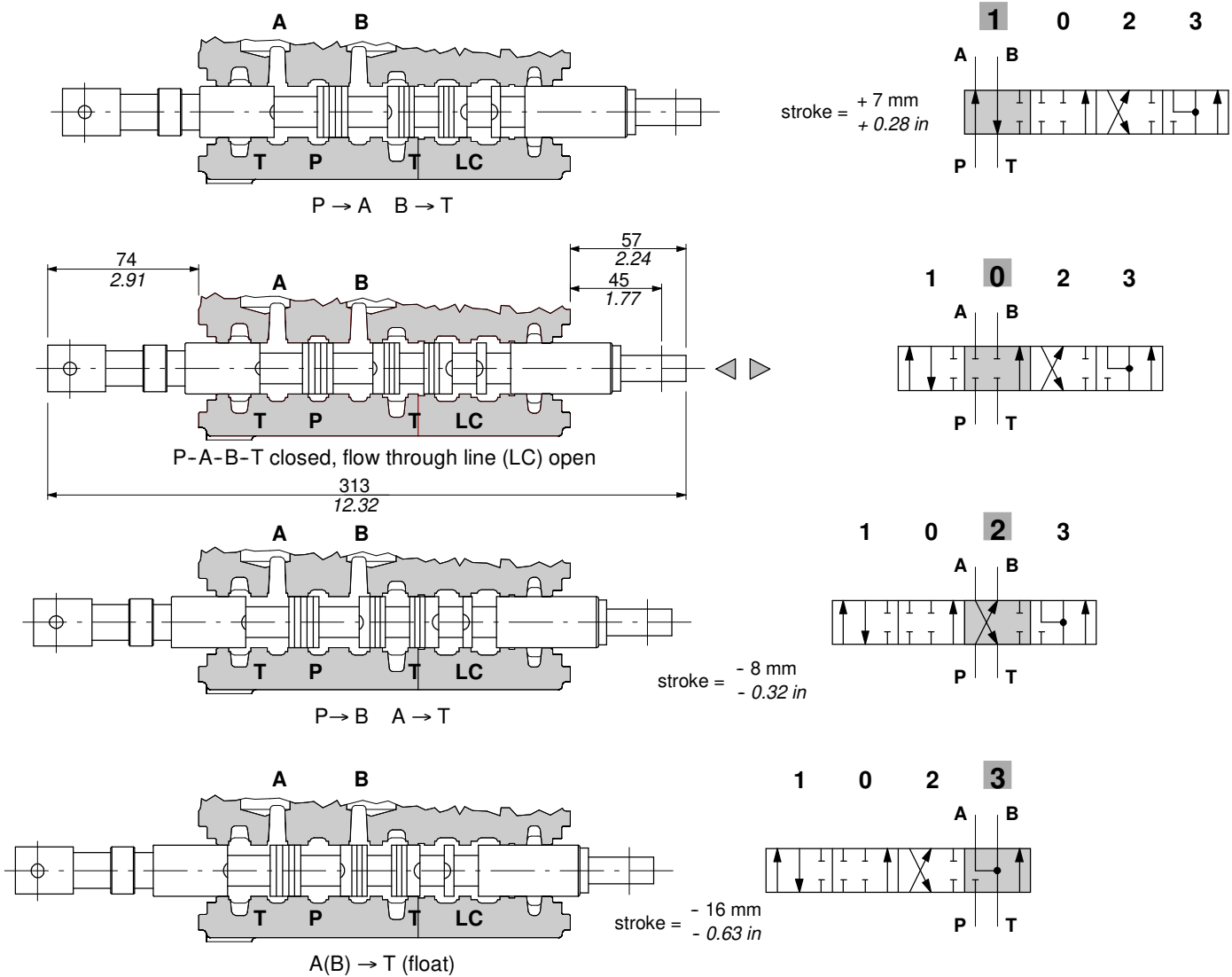

Performance data

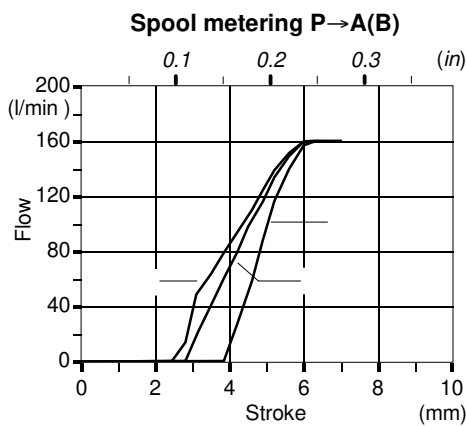

Q = 160 l/min

P(on ports) = 63bar/900psi
P(on ports) = 100bar/1450psi
P(on ports) = 250bar/3600psi

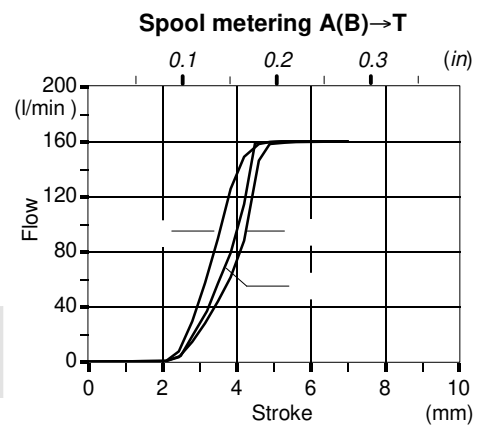

Type 8F

This spool needs special body with extra machining.

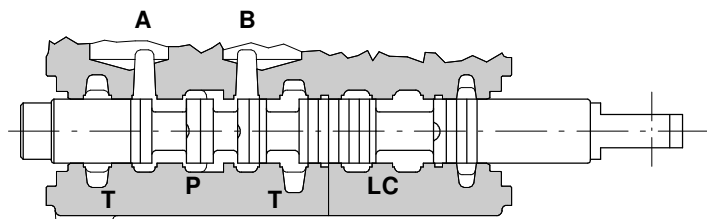

stroke = + 10 mm
+ 0.39 in

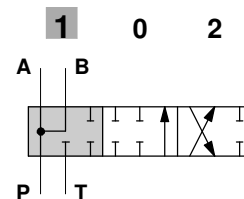

P → A+B (regenerative)

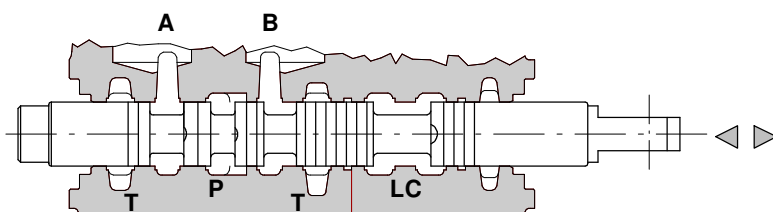

P-A-B-T closed, with flow through line (LC) open

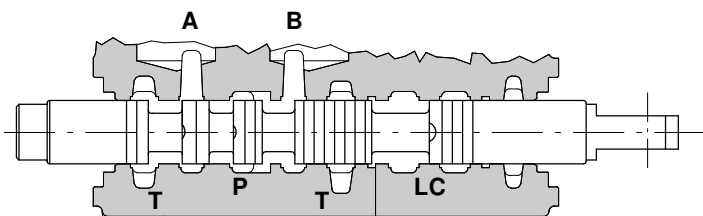
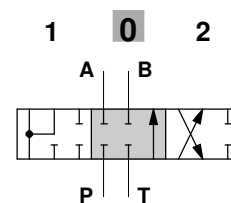

stroke = - 10 mm
- 0.39 in

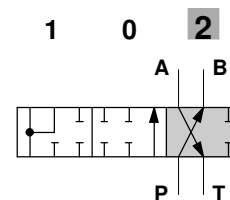

P → B A → T

Performance data

Spool metering P → B

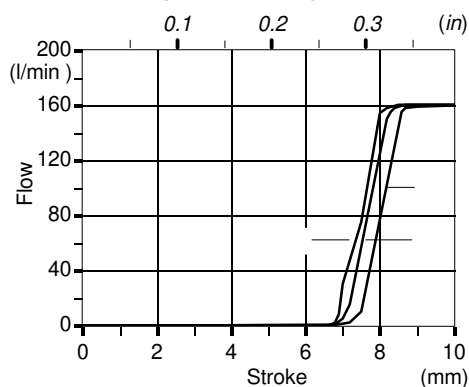

Q = 160l/min

- P (on ports) = 63bar/900psi
- P (on ports) = 100bar/1450psi
- P (on ports) = 250bar/3600psi

Spool pressure drop A → B

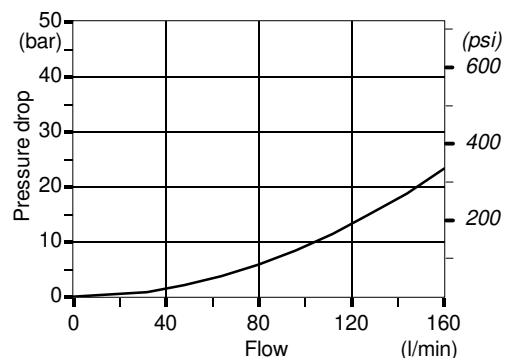

SD18

"A" side spool positioners

With spring return

8 kit

Supplied with standard spring type D (see force-stroke diagram); available with lighter spring type B (**8MB** code: 5V08220000) or type C (**8MC** code: 5V08120010).

In order to correctly apply these kits please contact Customer Service, there could be some usage limitation.

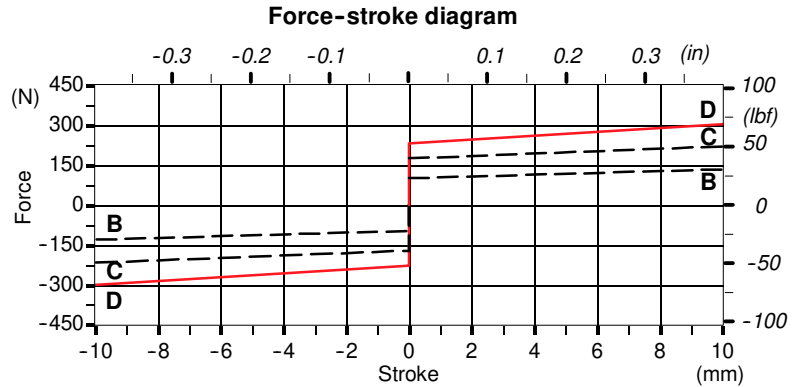
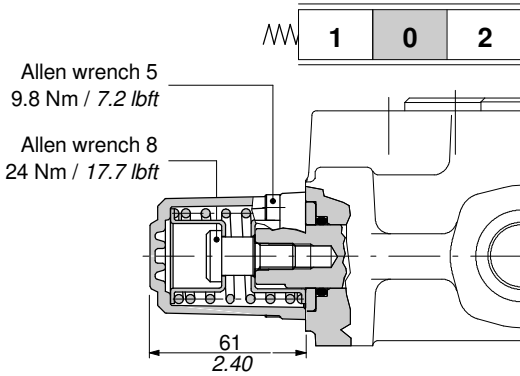

19 kit

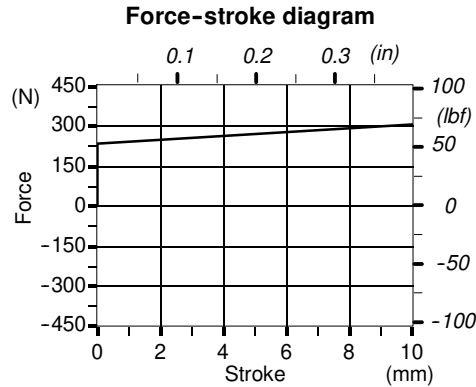
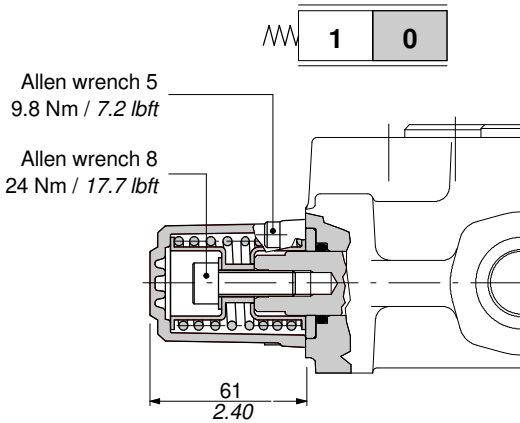

20 kit

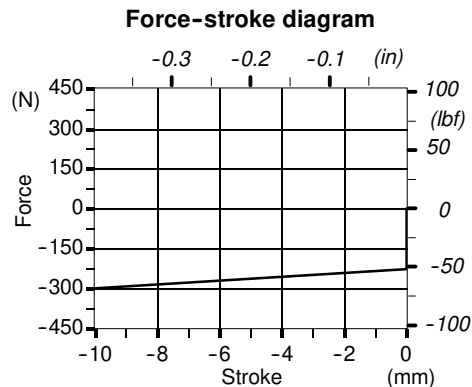
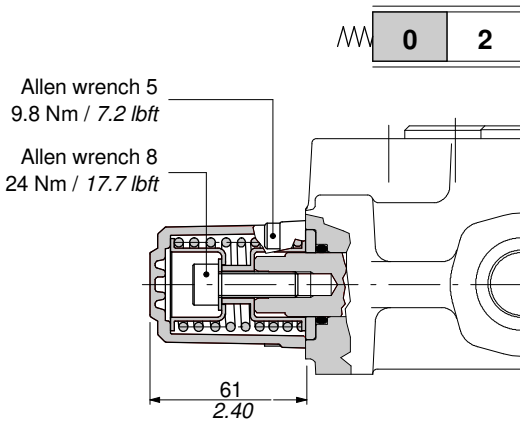

With detent

9B kit

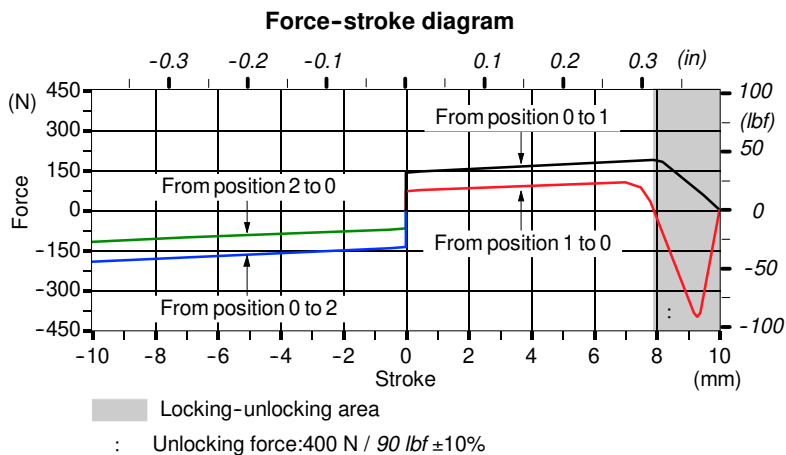
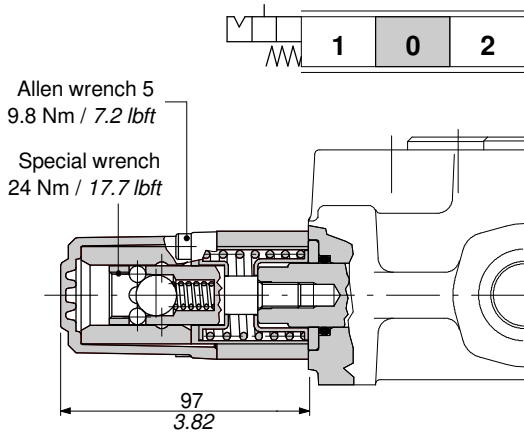

10B kit

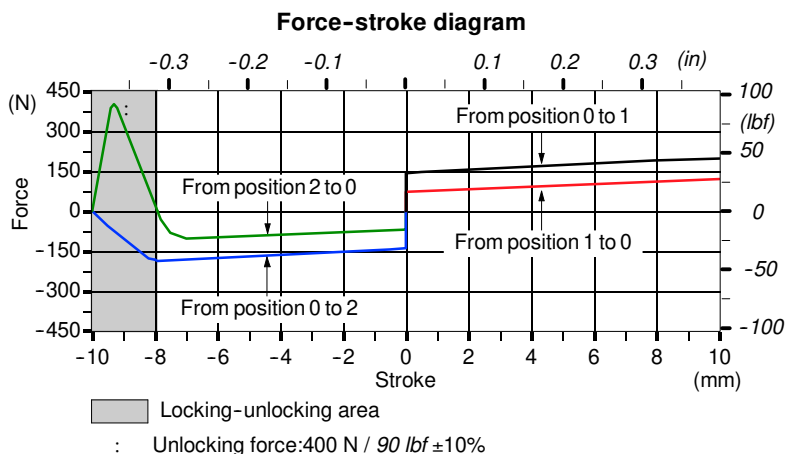
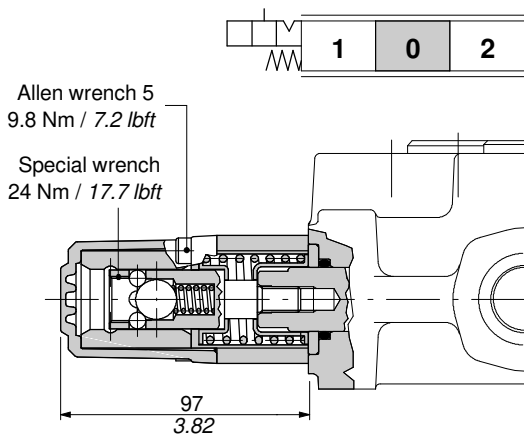

11B kit

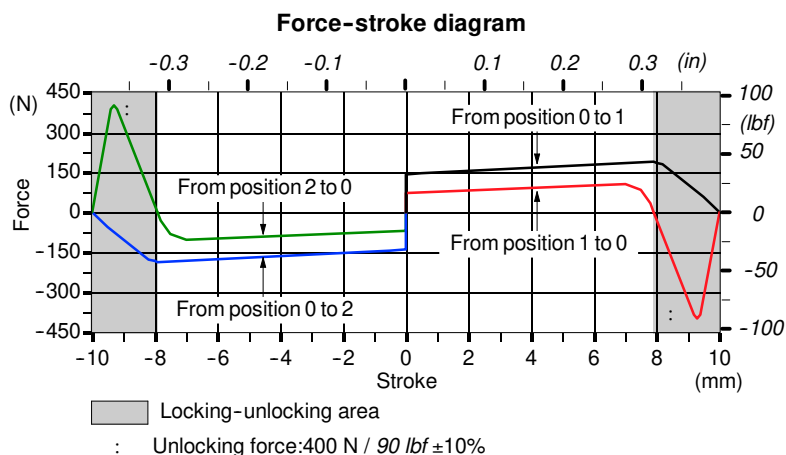
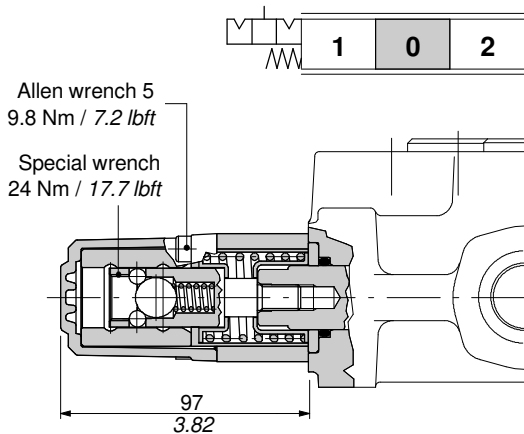

SD18

"A" side spool positioners

11 kit

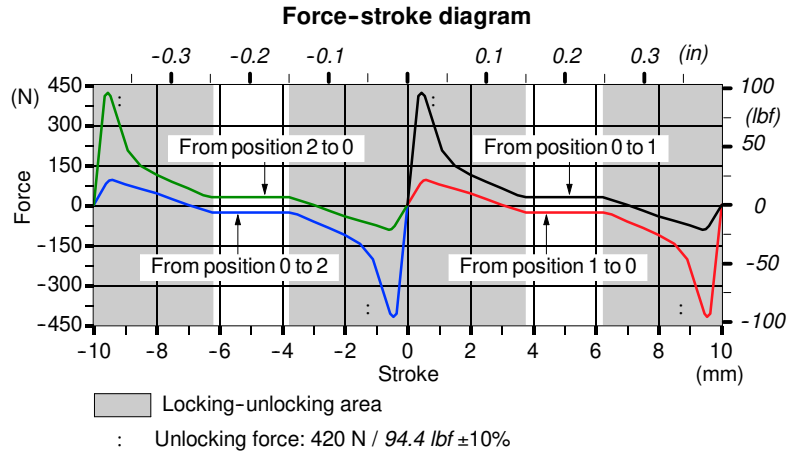
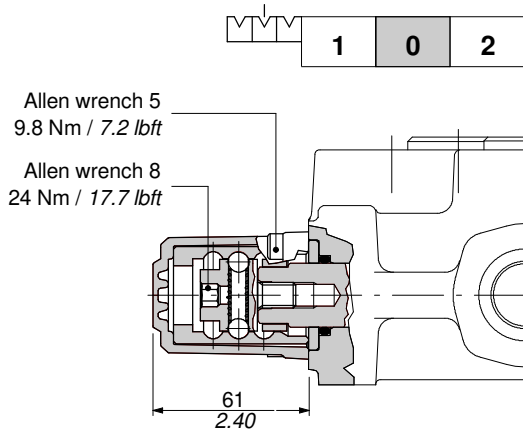

15 kit

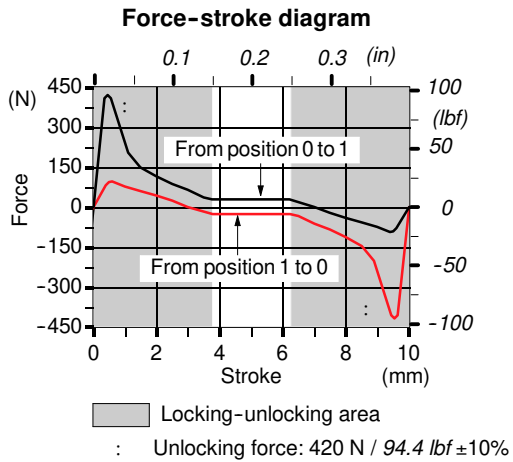
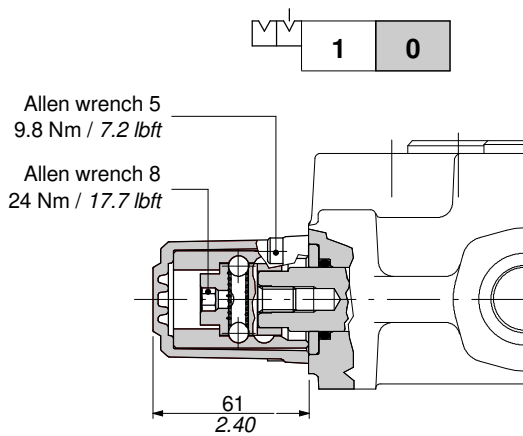

16 kit

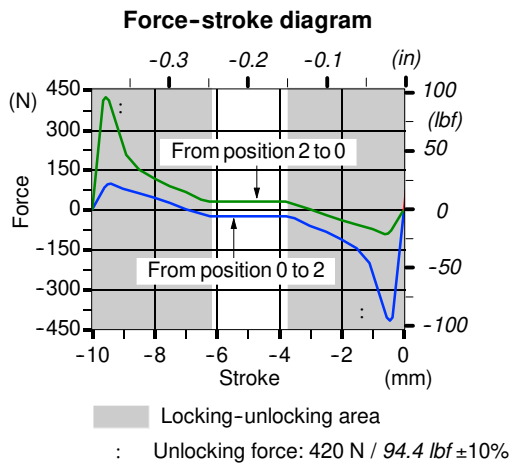
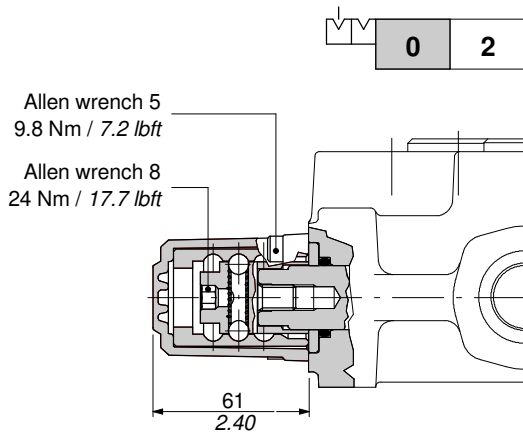

For spool type 5

13 kit

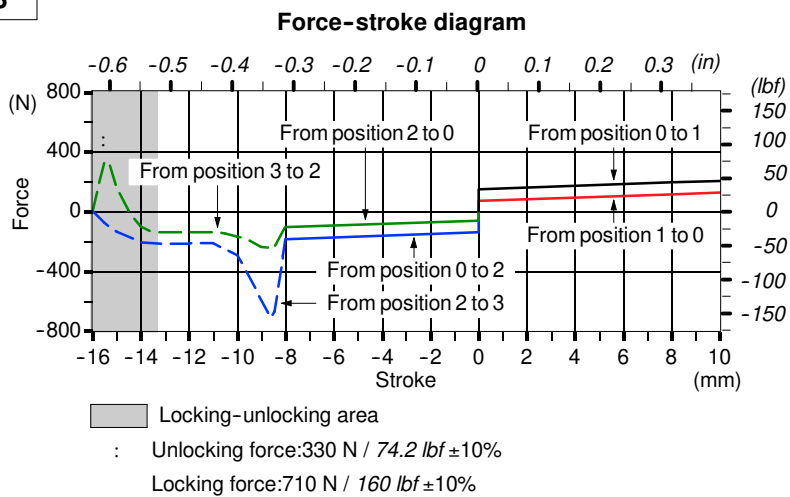
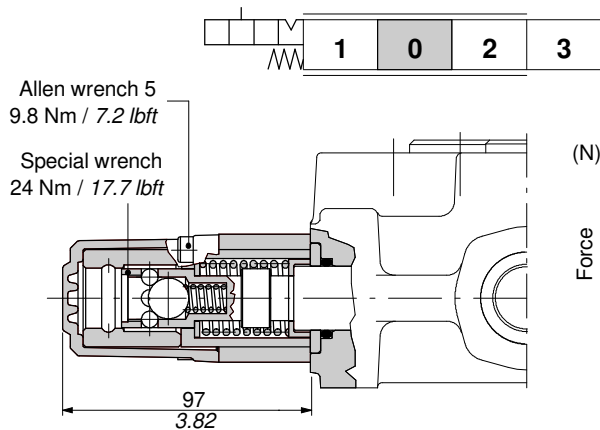

SD18

"A" side spool positioners

8P kit

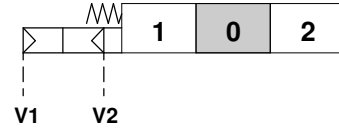
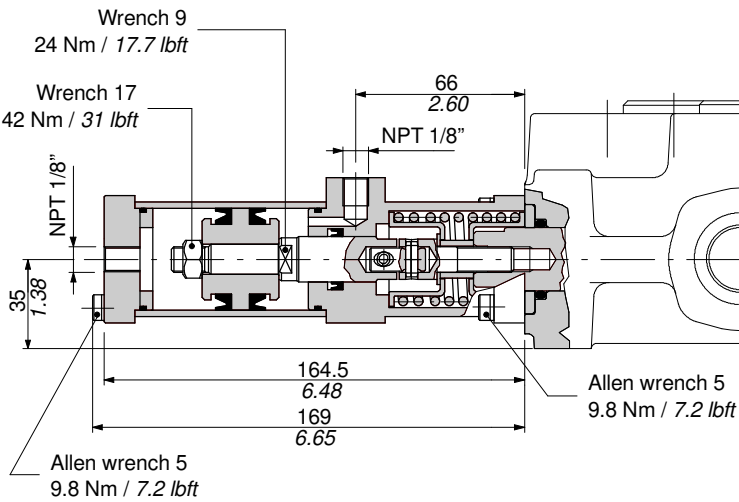

Operating features

Pilot pressure : 6 bar (max.10)
: 87 psi (max.145)

8EP3 kit

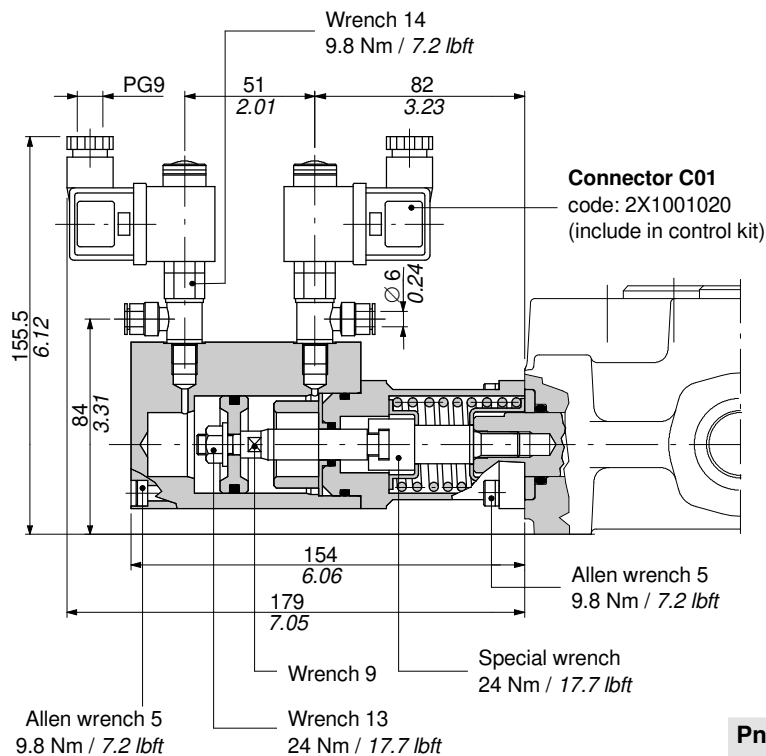

Scheme

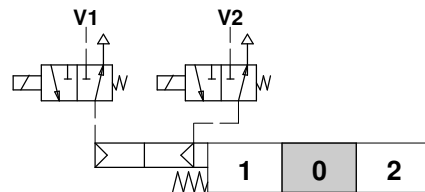

Scheme ISO 1219

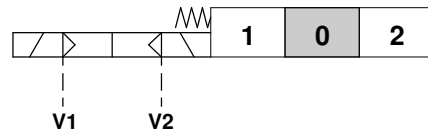

Operating features

Pilot pressure : 6 bar (max.10)
: 87 psi (max.145)

Solenoid operating features

Nominal voltage : 12 VDC / 24 VDC
Power rating : 8 W
Duty cycle : 100%

Pneumatic solenoid valve ordering code (with connector)

CODE	DESCRIPTION
2X4001012	12VDC solenoid valve
2X4001024	24VDC solenoid valve

8E13 kit

ON-OFF electro-hydraulic spool control kit with external pilot and drain.

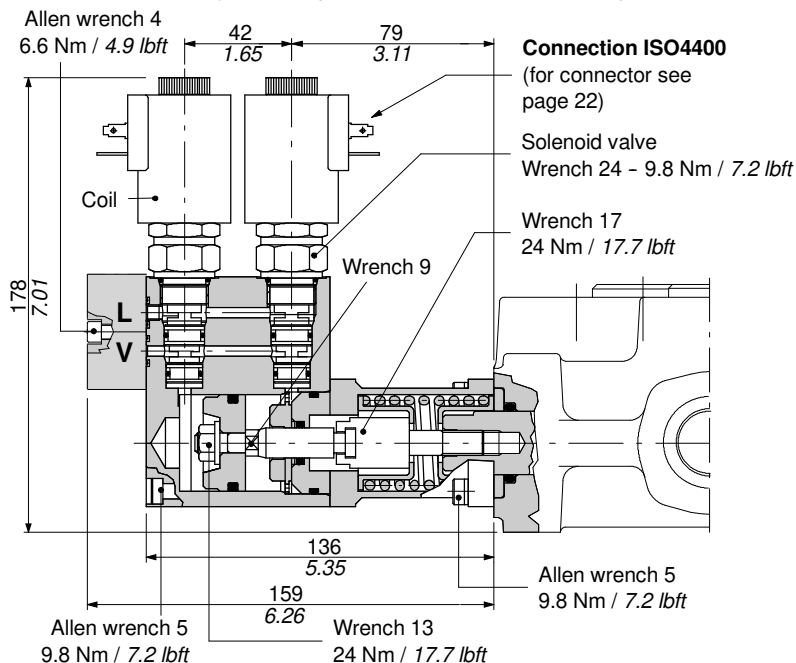

Scheme

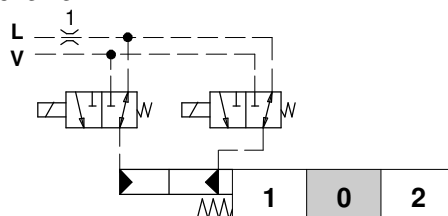

Scheme ISO 1219

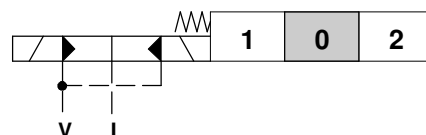

Operating features

Pilot pressure : min.10 bar - 145 psi
 : max.50 bar - 725 psi
 Max.back pressure on outlet L : 4 bar - 58 psi

Solenoid operating features

Nominal voltage : 12 VDC / 24 VDC
 Power required : 21 W
 Duty cycle : 100%

Valve and solenoids ordering codes

CODE	DESCRIPTION
2S0EJ08002013	3 ways solenoid valve
2X4350012	12VDC coil
2X4350024	24VDC coil

Collector kit for external pilot and drain

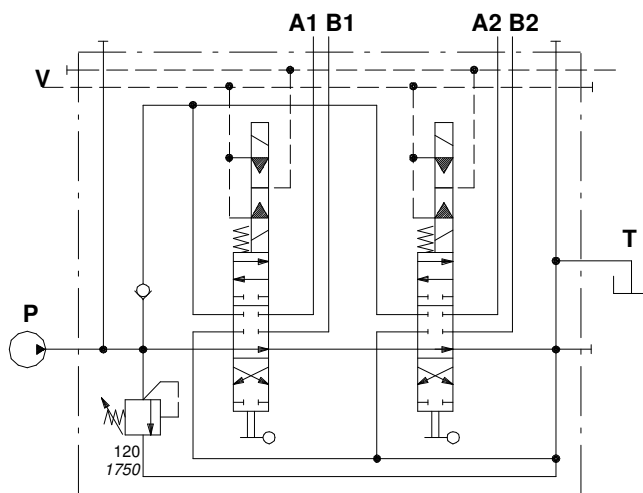
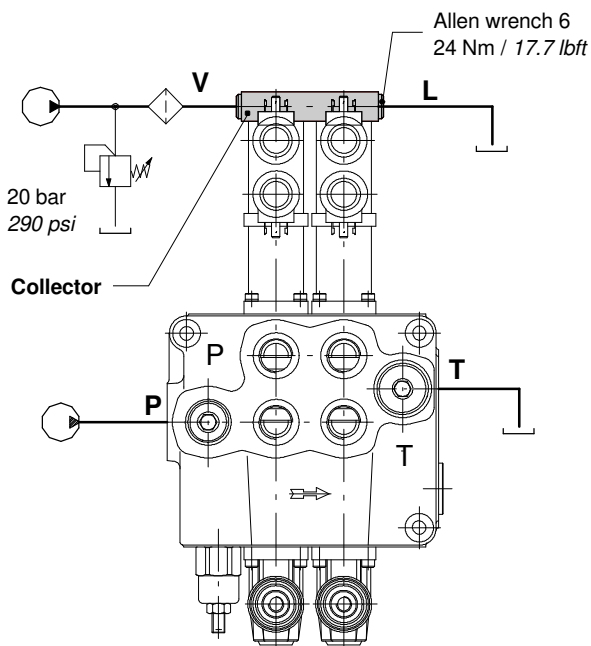

Ordering codes (BSP thread)

TYPE	CODE	DESCRIPTION
KE1S0	5KE1S00030	kit for 1 section
KE2S0	5KE2S00630	kit for 2 sections
KE3S0	5KE3S00630	kit for 3 sections
KE4S0	5KE4S00630	kit for 4 sections
KE5S0	5KE5S00630	kit for 5 sections
KE6S0	5KE6S00630	kit for 6 sections

Ex: SD18/2-P(KG3-120)/18E13L/18E13L/KE2S0-24VDC

SD18

"A" side spool positioners

8EI3 kit

Collector kit with pilot and drain lines

The kit consists of a collector with **VRP** pressure reducing valve and relative pipes.

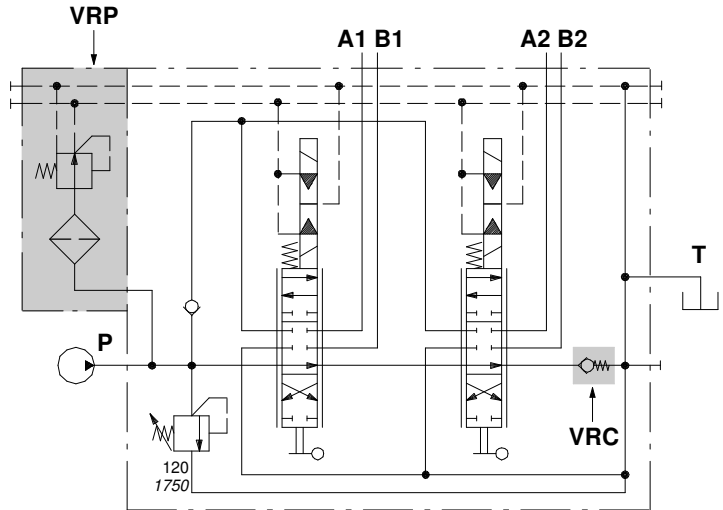
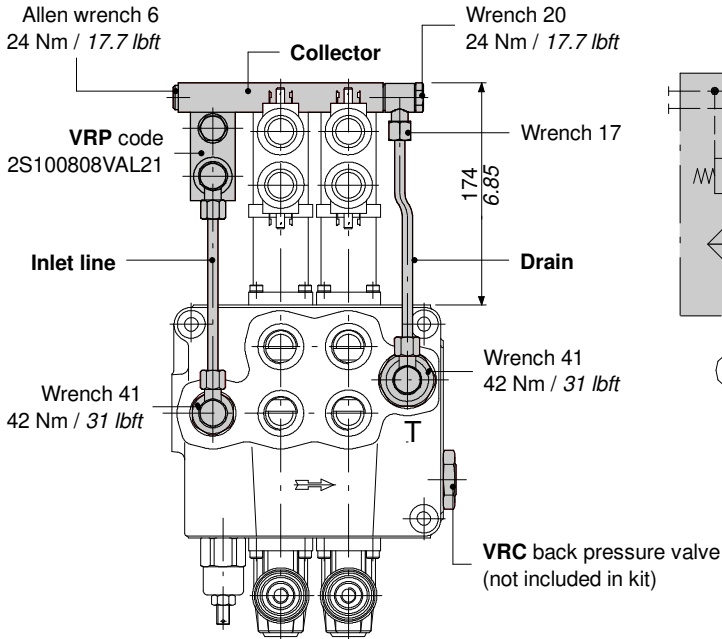

VRP valve operating features

Outlet pressure : 20 bar / 290 psi
 Max. flow : 8 l/min / 2.11 US gpm
 Filtering : 80 μ

Ex: SD18/2-P(KG3-125)/18EI3L/18EI3L/VRC
 -KE2R3-24VDC

Ordering codes (BSP thread)

TYPE	CODE	DESCRIPTION
KE1R3	5KE1R30630	kit for 1 section
KE2R3	5KE2R30630	kit for 2 sections
KE3R3	5KE3R30630	kit for 3 sections
KE4R3	5KE4R30630	kit for 4 sections
KE5R3	5KE5R30630	kit for 5 sections
KE6R3	5KE6R30630	kit for 6 sections

C02 connector code: 2X1001010

Connector according to ISO4400

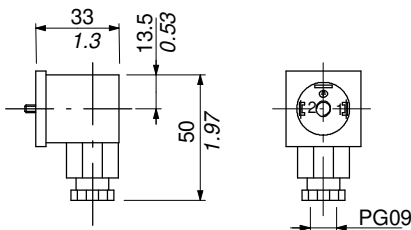

Operating features

Nominal voltage : 250 VAC / 300 VDC
 Weather protection : IP65

VRC valve : code XGIU541602

Valve assembled on flow through passage provides pilot pressure to the actuator.

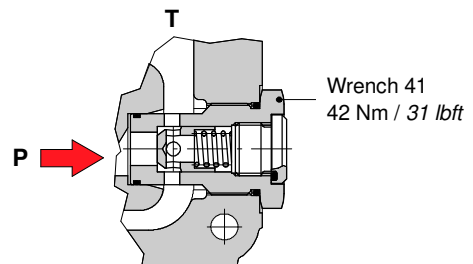

Pressure drop P→T

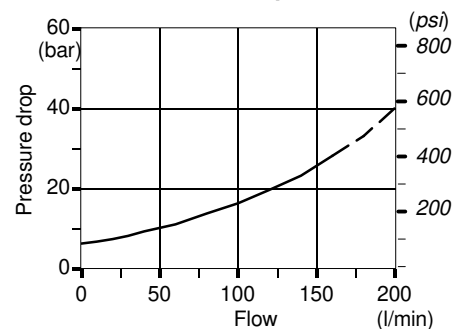

L lever box

Alluminium with protection boot lever pivot box; it can be rotated 180° (L180 configuration)

1	0	2
---	---	---

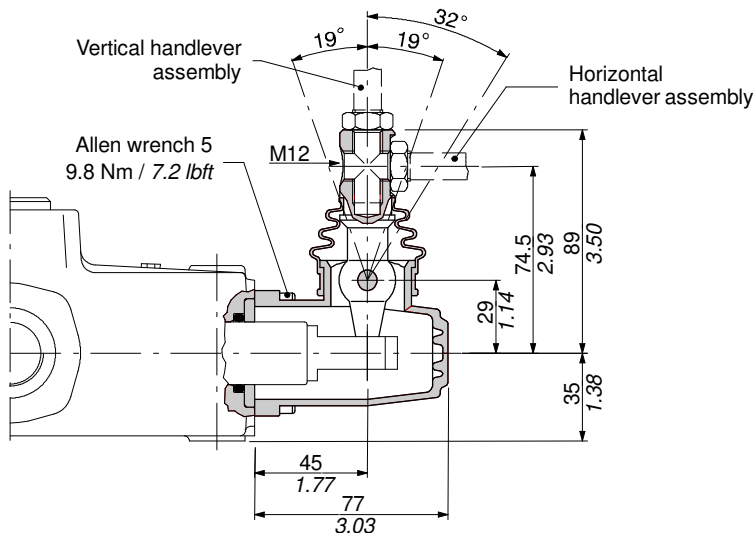

L180 configuration

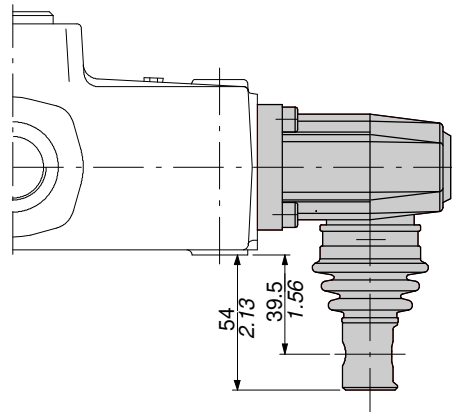

SLP dust proof plate

Mechanical control with dust proof plate.

1	0	2
---	---	---

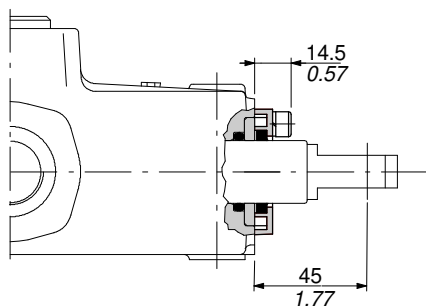

Spool dimension

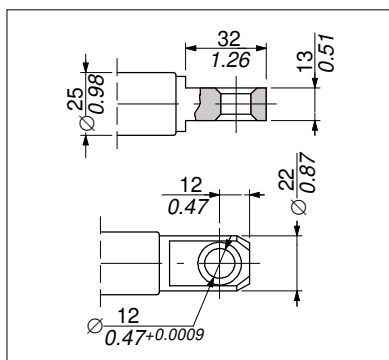

SLC cap

Protection cap usable with pneumatic spool and electro-hydraulic control kit.

1	0	2
---	---	---

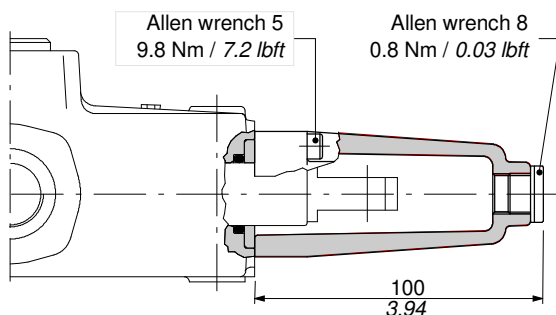

SD18

Hydraulic spool control

8IM kit (for single acting and double acting spools)

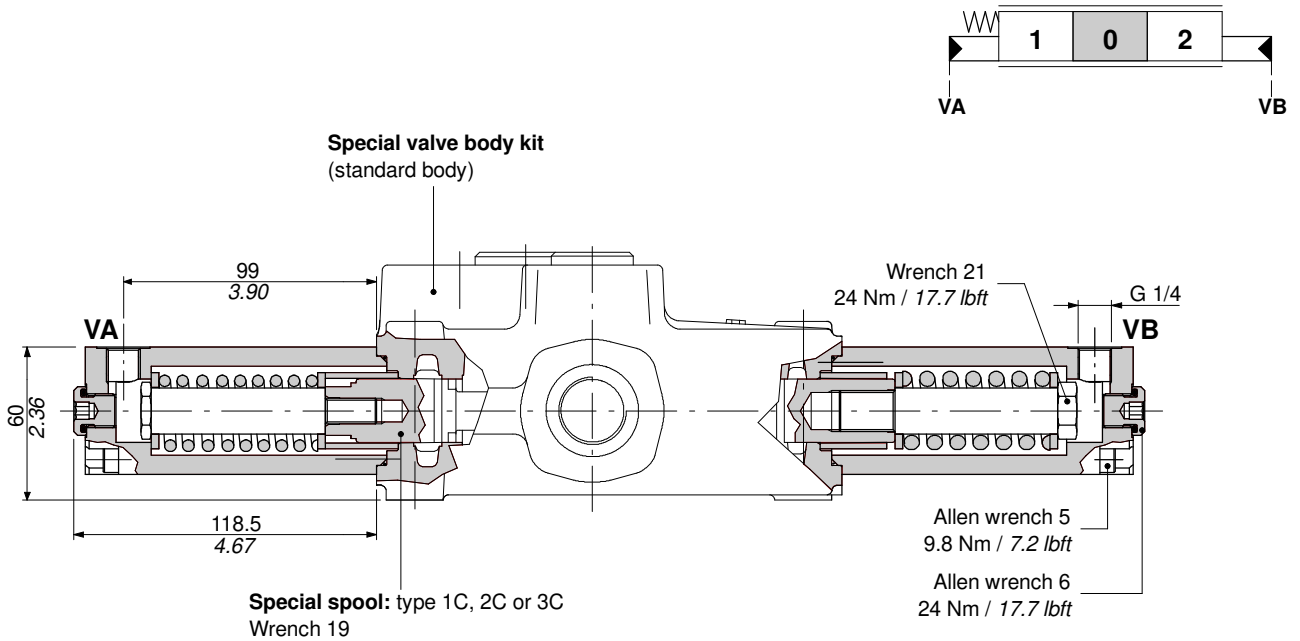

Pressure-stroke diagram

Max. pilot pressure 50 bar / 725 psi

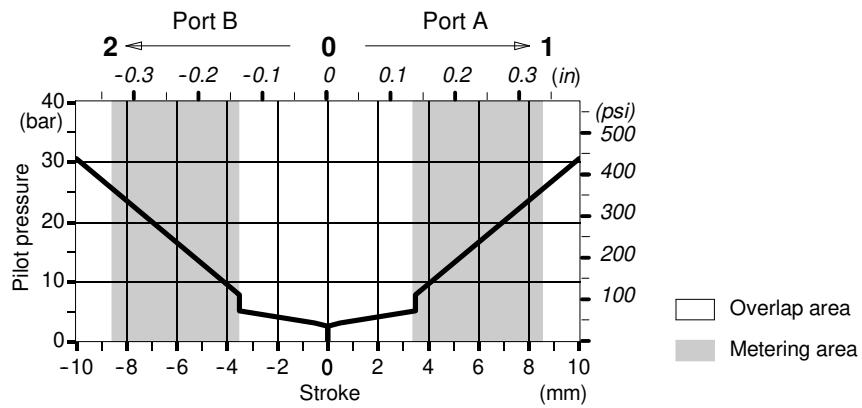

Connection example

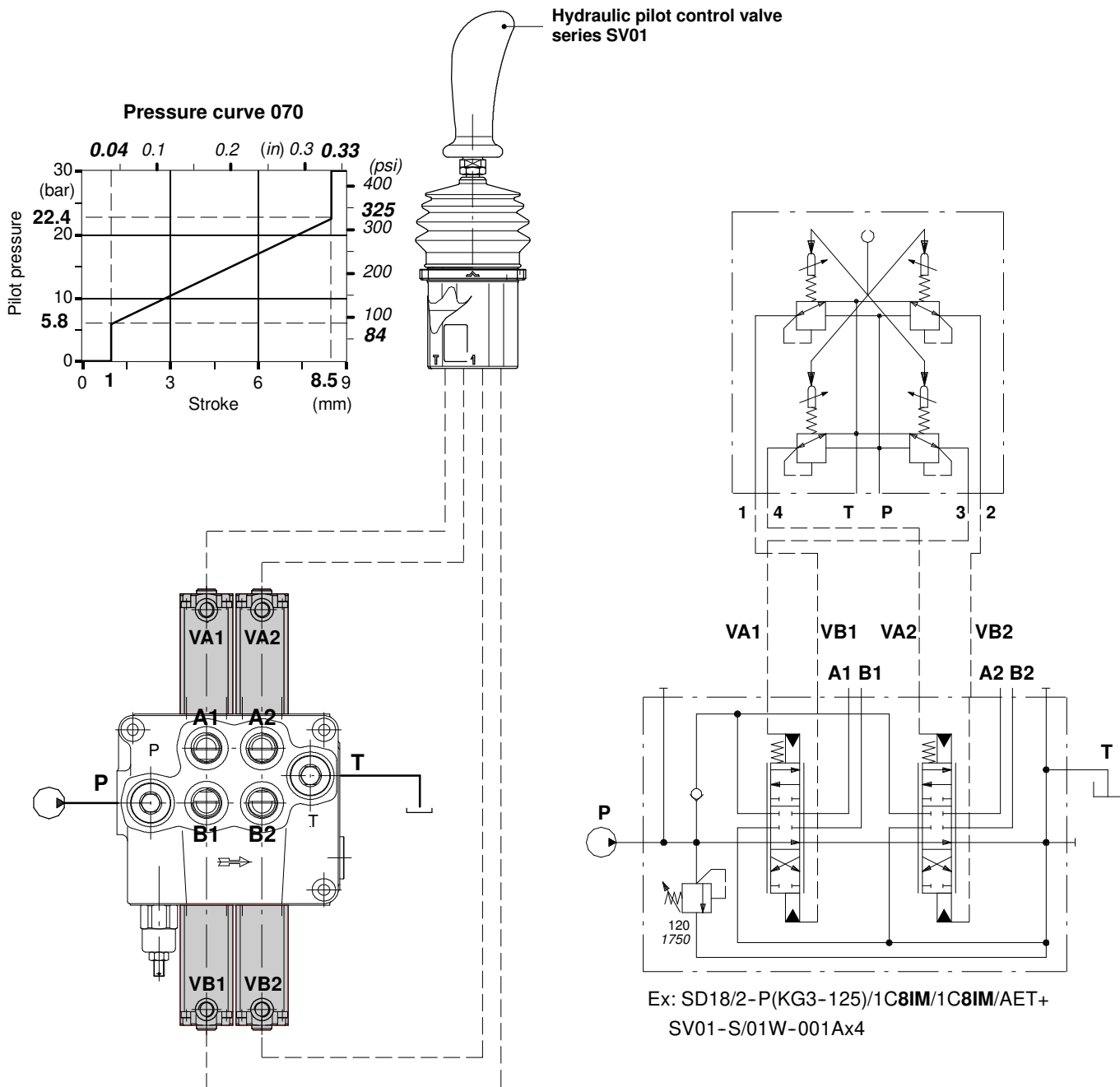

SD18

Port relief options

Complete kit with cast iron block and anti-shock valves

Example of mounting on directional valve

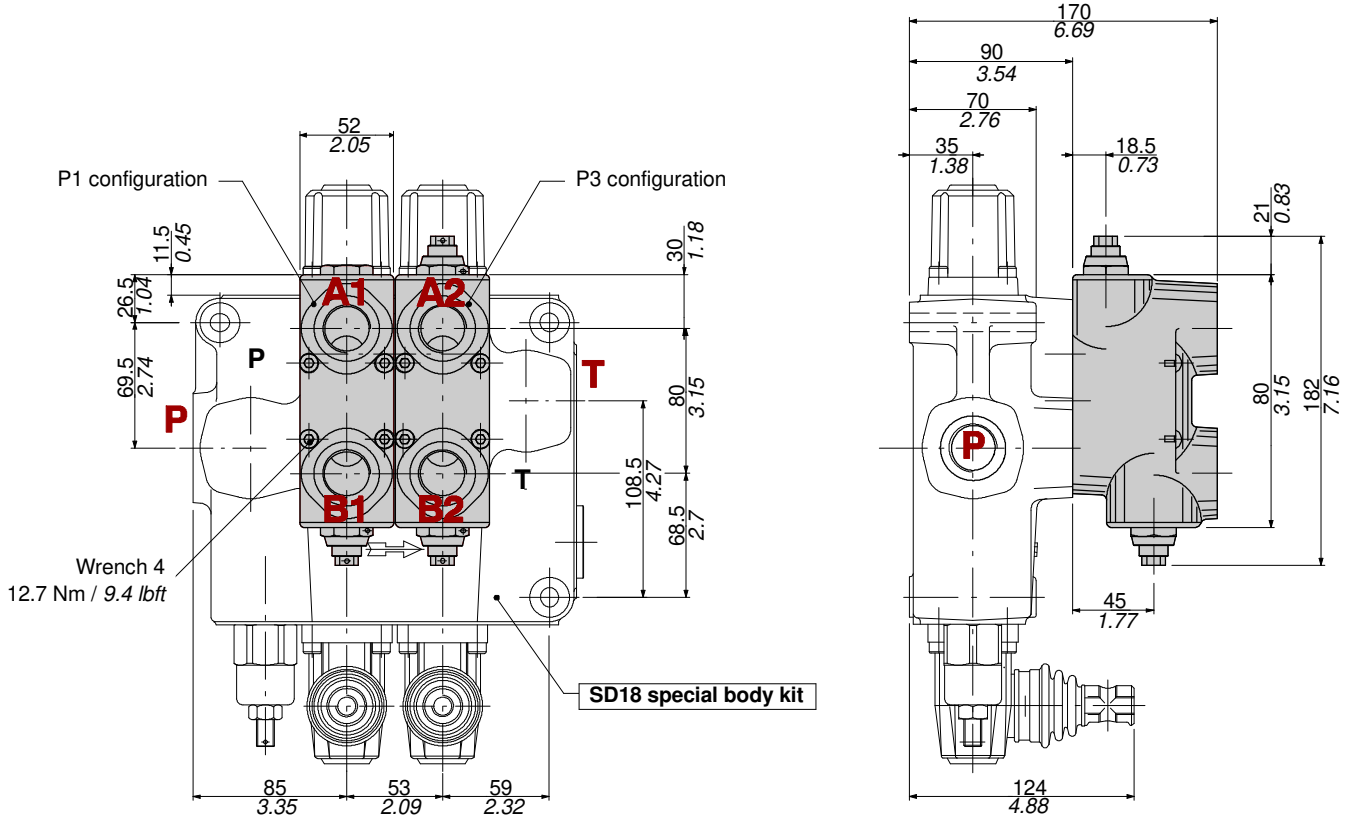

Example of SD18 valve with extra machining

When port valves are flanged on the first or the last section of the body, top inlet and outlet are not available.

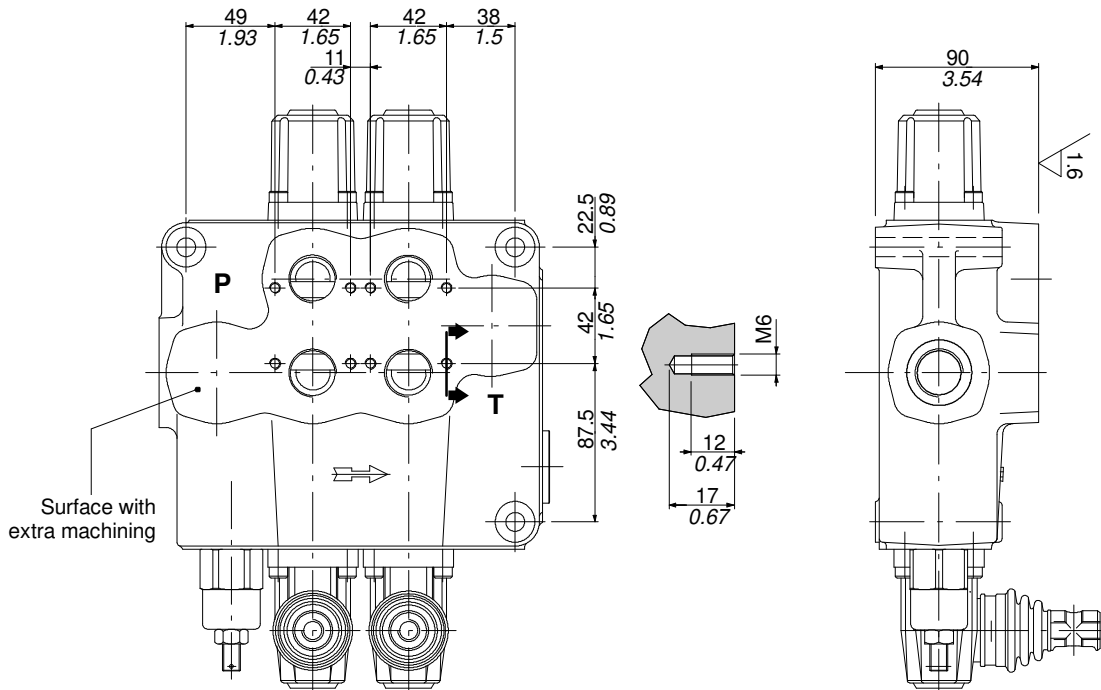

Port relief options

Circuit

P 1 (G 3 - 120)

- Setting value in bar standard 100 - 1450 (psi).
- Spring type (3).
- Adjustment type (G, H).
- 1 mounted on A port.
- 2 mounted on B port.
- 3 mounted on A and B ports.

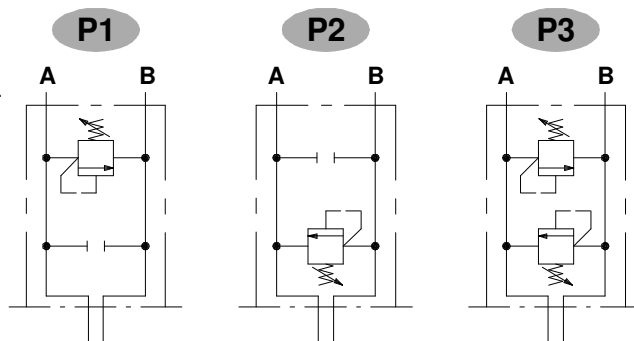

P1 configuration

Example of pressure on port A and port B to tank

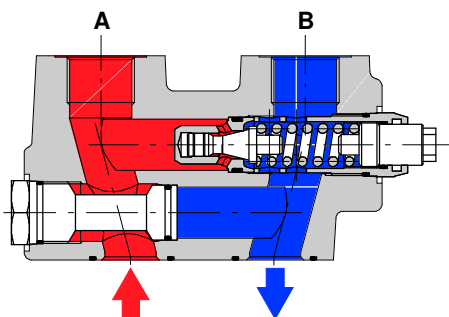

P2 configuration

Example of pressure on port B and port A to tank

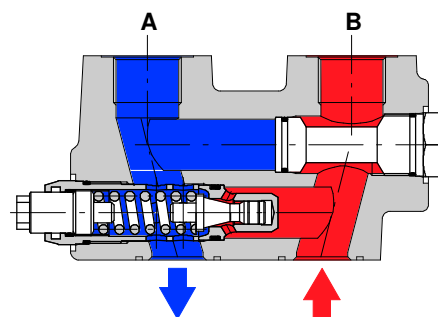

Adjustment type

G: with screw

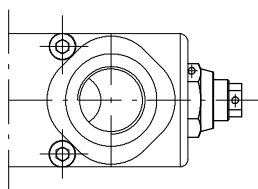

H: valve set and locked

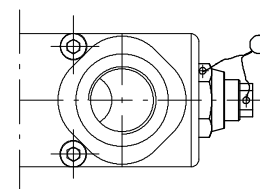

Performance data

Spring # 3 (blue band)

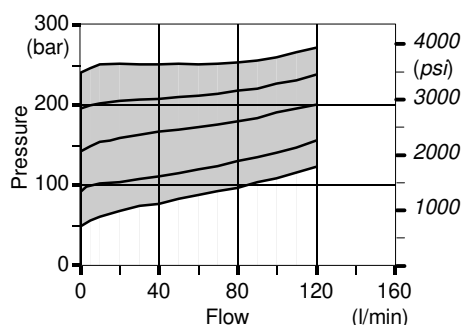

Response time

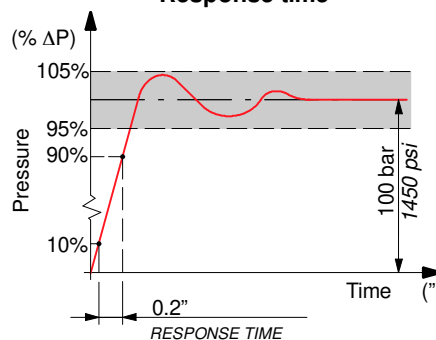

SD18

Outlet port conversion

AET: (standard)

See page 6

AE: with carry-over

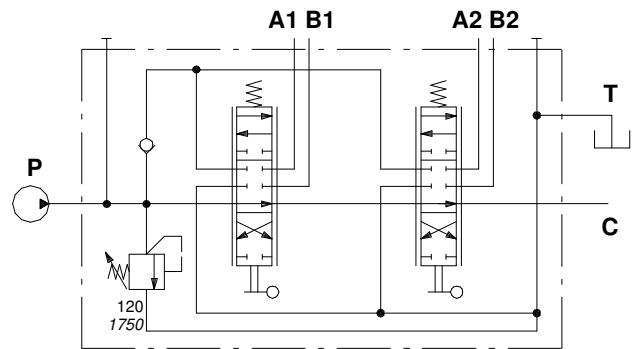
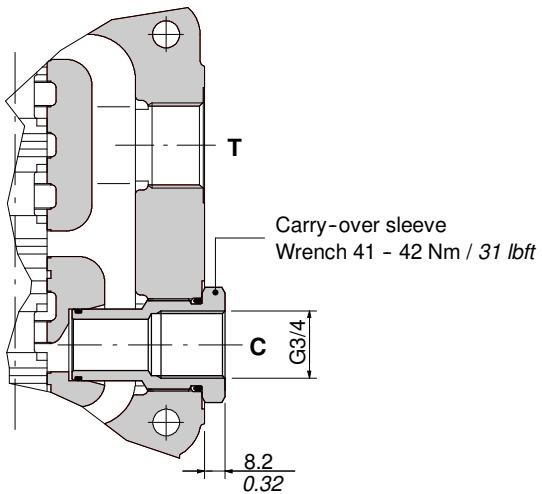

Ex: SD18/2-P(KG3-120)/18L/18L/AE

AEK: closed centre

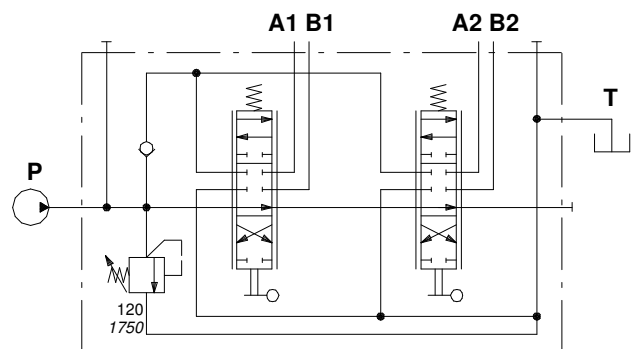
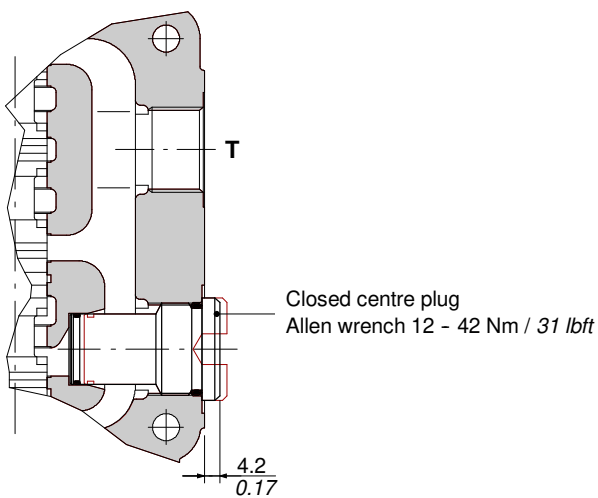

Ex: SD18/2-P(KG3-120)/18L/18L/AEK

Installation and maintenance

The SD18 valve is assembled and tested as per the technical specification of this catalogue.

Before the final installation on your equipment, follow the below recommendations:

- the valve can be assembled in any position, in order to prevent body deformation and spool sticking mount the product on a flat surface;
- in order to prevent the possibility of water entering the lever box and spool control kit, do not use high pressure wash down directly on the valve;
- prior to painting, ensure plastic port plugs are tightly in place.

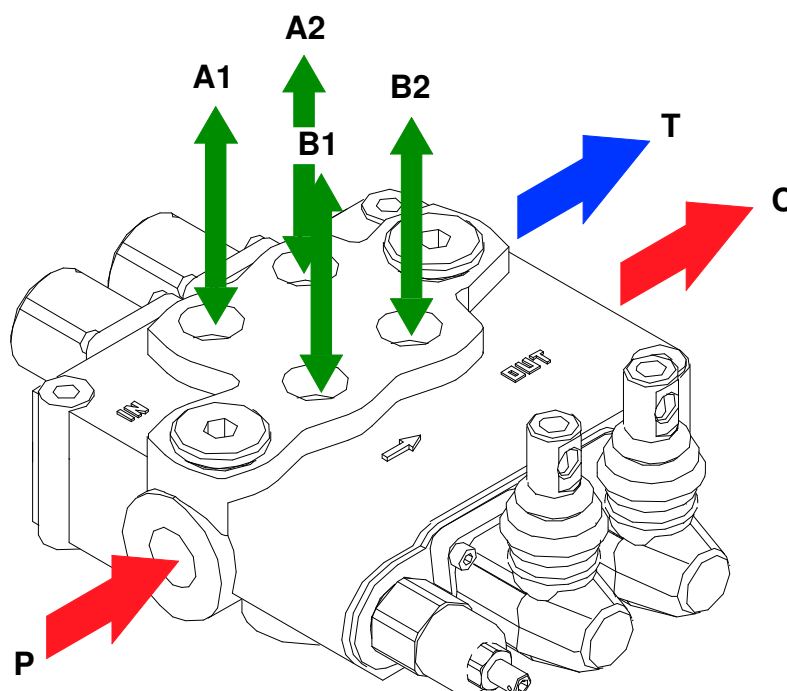

Carry-over configuration

Fitting tightening torque - Nm / lbft

THREADS TYPE	P and C ports	A and B ports	T port
BSP (ISO 228/1)	G 3/4	G 3/4	G 1
With O-Ring seal	90 / 66.4	90 / 66.4	100 / 73.7
With copper washer	90 / 66.4	90 / 66.4	90 / 66.4
With steel and rubber washer	70 / 51.6	70 / 51.6	100 / 73.7
UN-UNF (ISO 11926-1)	1 5/16-12 UN-2B (SAE 16)	1 1/16-12 UN-2B (SAE 12)	1 5/16-12 UN-2B (SAE 16)
With O-Ring seal	150 / 110.6	95 / 70.1	150 / 110.6

NOTE - These torque are recommended. Assembly tightening torque depends on many factors, including lubrication, coating and surface finish. The manufacturer shall be consulted.

Installation and maintenance

O-Ring seal 24.99x3.53
code: 4GUA125035

Chamfer

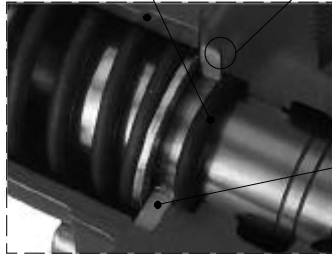

Holding O-Ring
bushing

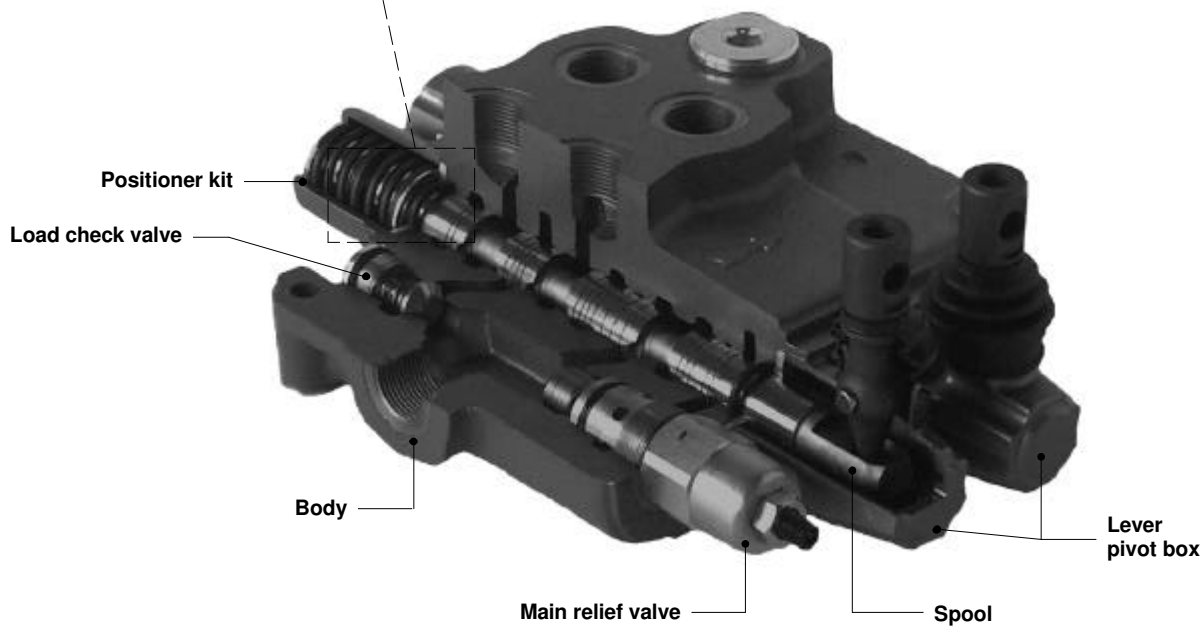

Normally spools are interchangeable. Verify the smoothness during the assembly

NOTE - All articulated parts inside cap, lever box and mechanical joystick are lubricated with synthetic base grease grade NLGI2

Malfunction	Cause	Remedy
External leakage pivot box lever or control kit side.	Worn spool seal due to mechanical actuation or high back pressure.	Locate the leakage and replace the seal. Check back pressure level.
Excessive internal leakage on A and B ports.	Increase clearance between spools and body due to high wear	Replace the directional control valve and check the oil contamination level.
Dropping load during transition while raising	High leakage on the load check valve.	Remove the load check valve and clean the seat.
Inability to build pressure on A and B ports.	Pressure relief valve blocked open. Low pump pressure and flow.	Remove and clean or replace the valve. Check the pump and circuit.



WALVOIL S.P.A.

42100 REGGIO EMILIA • ITALY • VIA ADIGE, 13/D
TEL. +39.0522.932411 • FAX +39.0522.300984
E-MAIL: INFO@WALVOIL.COM • HTTP: //WWW.WALVOIL.COM

SALES DEPARTMENT

TEL. +39.0522.932555 • FAX +39.0522.932455

DAT006E